



PRODUCT CATALOG

No. 3



65th Anniversary Edition
Established 1948

broadcast | wireless | sports lighting | utility | wind | transportation

Thank you for your interest in ROHN Products

For over sixty five years the ROHN name has been a leader in the telecommunications industry. The company has used our expertise in structural design and fabrication to expand into additional markets. ROHN is proud to service the major utility and wind energy companies in North America. These markets are just two of the latest to join telecom, sports lighting, broadband, broadcast and the others that have been using ROHN Products to support their infrastructure projects for six decades.

We are proud to offer the latest version of the ROHN Products Catalog (No. 3). There

If you have any questions, comments or suggestions regarding this catalog or any ROHN products, we are just a phone call away. On the adjacent page we have listed contacts that can assist you with any questions.

ROHN is committed to providing you the best products in the industry. Our towers are standing on every continent and in nearly every country around the world. That is because we are recognized around the globe as the quality leader in structures. We strive to continue that tradition this year and in the years to come.

We appreciate your interest in our products and we appreciate your business.

Never Accept Second Best - Call ROHN
309-566-3000



The Industry Standard
Since 1948

The information contained in this catalog is intended to assist customers in selecting the appropriate ROHN product for specific applications. The information, drawings, etc. are not intended to be substituted for assembly drawings provided with a ROHN product. Dimensions and weights provided in this catalog are nominal. Refer to our website www.rohnnet.com for additional information and products. Due to continuous product improvement, all specifications and data are subject to change without notice or obligation. 2-2013 All Rights Reserved Copyright 2013

SALES TERRITORIES

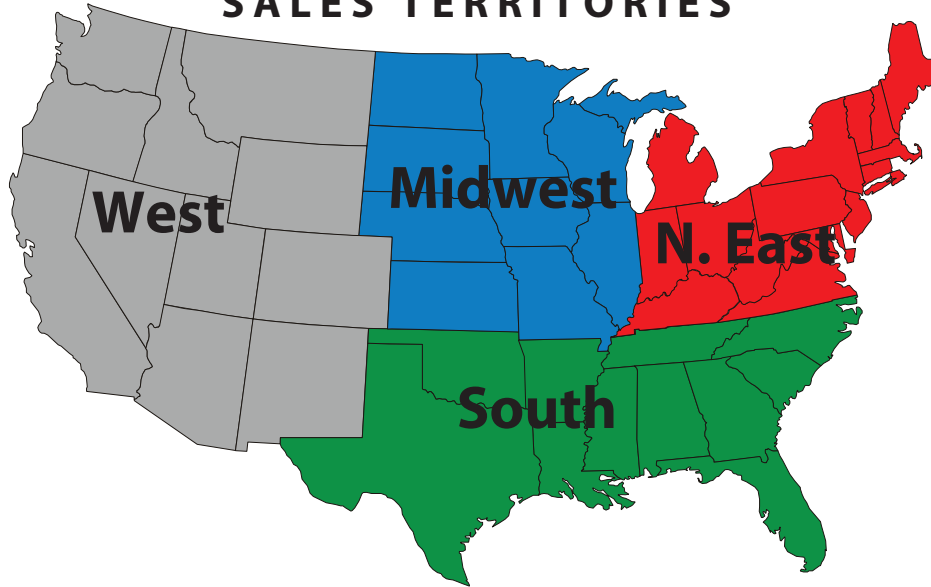

ORDERS ORIGINATING IN WESTERN UNITED STATES

Joel Stone
309.566.3007
joel.stone@rohnnet.com

ORDERS ORIGINATING IN MIDWEST UNITED STATES & WIND ENERGY

Scott Burdette
309.566.3010
scott.burdette@rohnnet.com

ORDERS ORIGINATING N. EASTERN UNITED STATES

Ken Cordrey
410.556.6201
ken.cordrey@rohnnet.com

ORDERS ORIGINATING IN SOUTH & SOUTHEAST UNITED STATES

Mike Parrish
863.644.9226
mike.parrish@rohnnet.com

INTERNATIONAL TELECOM & BROADCAST (Outside of U.S.)

Sabet Borairi
905.616.5953
sabet.borairi@rohnnet.com

TRANSPORTATION & UTILITY

Jeff Arends
309.566.3004
jeff.arends@rohnnet.com

DOT-TRANSPORTATION

Adam Lofgren
309.566.3005
adam.lofgren@rohnnet.com

For general information or comments, please contact us at (800) 727-ROHN, (309) 566-3000 or info@rohnnet.com



Company History	6
Industries We Serve	7-12
Understanding TIA-222 - Revision G	13-20

GUYED TOWERS 21-157

G-Series Towers	22-23
25G General Use & Features	24-25
Standard Designs (90mph 110mph 130mph)	26-36
Parts & Accessories	37-40
Grounding & Foundations	41-44
45G General Use & Features	46-47
Standard Designs (90mph 110mph 130mph)	48-62
Parts & Accessories	63-65
Grounding & Foundations	66-69
45GSR General Use & Features	70-71
Standard Designs (90mph 110mph 130mph)	72-91
Parts & Accessories	92
Grounding & Foundations	93-97
45GSR Meteorological Towers General Use & Features	98-99
55G General Use & Features	100-101
Standard Designs (90mph 110mph 130mph)	102-114
Parts & Accessories	115-116
Grounding & Foundations	117-120
65G General Use & Features	122-123
Standard Designs (90mph 110mph 130mph)	124-140
Parts & Accessories	141-142
Grounding & Foundations	143-146
General Notes for G-Series Guyed Towers	147
G-Series Foundation General Notes	147-149
Guy Arrangement Details	150
Guy Connection Details	151-152
Assembly Bolt Installation	153
80 General Use & Features	154-155
90 General Use & Features	156-157



BRACKETED TOWERS**159-163**

G-Series Bracketed Towers General Use & Features	160
25G Bracketed Tower & Foundation	161
45G Bracketed Tower & Foundation	162
55G Bracketed Tower & Foundation	163

SELF-SUPPORTING TOWERS**165-199**

G-Series Self-Supporting General Use & Features	166
G-Series Self-Supporting Loading Charts - No Ice [Rev F]	167
G-Series Self-Supporting Loading Charts - No Ice [Rev G]	168
Design Notes & Foundation Information	169-170
65G Camera Tower	172
Standard Foundation Details & Accessories	173
VG Camera Tower	174
Standard Foundation Details & Accessories	175
RSL General Use & Features	176
Ordering Info & Design Notes	177
Standard Designs (20' - 100')	178-183
Accessories	184-185A
Grounding Information	185A
Base Kits & Foundations	185B
Optional Items	185C
SSV Standard General Use & Features	186
Standard Loading Chart (90 MPH, 3/4" ICE)	187
Standard Loading Chart (100 MPH, 3/4" 1LE)	188
SSV Heavy Duty General Use & Features	190
Heavy Duty Standard Loading Chart (90 MPH, 3/4" ICE)	191
Heavy Duty Standard Loading Chart (100 MPH, 3/4" ICE)	192
Heavy Duty Standard Loading Chart (110 MPH, 3/4" ICE)	192
SSV ANSI/TIA-222-G Standard Foundations	193
SSMW General Use & Features	194
Standard Section Detail	195
SSVSR General Use & Features	196
Standard Section Detail	197
RS General Use & Features	198
Standard Section Detail	199

TOWER & SITE ACCESSORIES**201-218**

Side Arms	202
Leg Dish Mounts	203
Tie-Back Assemblies	204
Face Dish Mounts	205-206
Sector Mount	207

TOWER & SITE ACCESSORIES [continued] 201-218

Rotor Plate Assemblies	208
Safety Device & Safety Cable	209
Climbing Ladders	210
Waveguide Ladders	211-213
Waveguide Brackets	214-216
Waveguide Bridges	217-218

POLES 219-241

Direct Embed Poles General Use & Features	220
Standard Loading Charts	221-224
Accessories	225
Antenna Index	226
Pre-Engineered Utility Poles General Use & Features	227
Standard Loading Charts	228-233
Accessories	234
Utility Structure Information	236-237
Transportation Structure Information	238-239
Wind Turbine Structures	240-241

TELESCOPING MASTS 243-249

General Description	244
Mast Details	245
H20 Typical Guy Layout	246
H30 Typical Guy Layout	246
H40 Typical Guy Layout	247
H50 Typical Guy Layout	247
9H50 Typical Guy Layout	248
Parts & Accessories	249

ROOF MOUNTS 251-273

Effective Wind Velocity Formula Sheet	252
FRM	253
JRM	254-256
BRM4	257-259
BRM6	260-263
NPPK	264
25GBRM	265-266
AAGM	267-268
PRM6	269
Ballast Requirements	270
URM	271

ROOF MOUNTS [continued]	251-273
SHRM	272
TRT	273
WALL MOUNTS	275-279
1LG	276
PWM	277
WM4 / WM212 / Extended Mounts	278
G-Series Wall Mounts	279
TOWER MODIFICATION MATERIAL	281-288
Guyed Towers	282-285
Self-Supporting Towers	286-287
Guy Anchor Selection Chart	288
GENERAL TOWER HARDWARE	289-302
Nuts, Bolts & Washers	290-295
Guy Material	295-298
Grounding	299
Steel Tubing & Mounting Pipe	300-301
Miscellaneous	302
TOWER LIGHTING GUIDELINES	303-308
Style "A"	304
Style "B"	305
Style "C"	306
Style "D" / Style "E"	307
Style "F"	308
INFORMATION	309-317
Construction Services	310
Considerations, Recommendations & Safety Information	311
Erection	312
Recommendations for Communication Tower Specifications	313
Guidelines for Preparing a Geotechnical Report	314
General Safety Information	315-316
Terms & Conditions of Sale	317



HISTORY



Founded in 1948, in Peoria, Illinois by Dwight Rohn, the ROHN product quickly became the industry standard for towers. The need for ROHN structures grew out of the television industry and a need for homeowners to have small towers adjacent to their homes to enable signal reception. The demand grew quickly and the company's knowledge and capacity were forced to grow with it. Soon television reception towers grew into radio towers, microwave towers, lighting structures and more. When the cellular technology exploded in the U.S., ROHN was there to provide the towers to support the rapid growth. This growth was not just in markets but in geographies.



By 1980, ROHN had structures standing on every continent and in nearly every country on the globe. We continue to supply towers and poles to all of the communication giants and regional carriers. We support utilities and transportation in all of North America. We have wind turbine towers and meteorological towers across the globe. For over 60 years, our products have endured and our name continues to be recognized around the world as the industry standard.

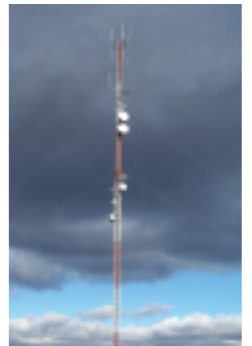

BROADCAST SOLUTIONS



When Americans turned on their first television sets, ROHN was there to improve fuzzy reception with our home antenna tower. During the 40's and 50's, a ROHN TV tower installed on a rooftop or in a backyard meant that family's TV reception was the best on the block, even if the picture was only black and white and the screen just 12 inches wide.

ROHN's business serves the broadcast side of TV as well. With the advent of digital TV and compliance with FCC standards, broadcasters are choosing to remain competitive by expanding their services into more areas. To do so, they look to ROHN to deliver "Tall Towers", super structures rising as high as 2,000 feet, to broadcast TV signals to millions of viewers in a much wider geographic area.



ROHN towers are some of the tallest structures in the world, and we build each tower in accordance with our exacting standards for quality, performance and structural integrity. Our tall towers are helping change the way the world receives and views television signals. This innovation is nothing new for ROHN. Back in 1948 when we started our business, we were on the forefront of the television age. Today, we stand ready to serve the next wave of television broadcasting.





WIRELESS SOLUTIONS



ROHN has been supplying towers to the wireless industry since the industry was born. Whether the application is microwave, cellular, PCS or broadband, we have the towers in service supporting wireless communications.

When the first microwave towers were constructed in the United States, ROHN was the quality supplier of choice. We designed and fabricated to the most stringent standards for wind, ice and dish twist and sway requirements.

As the communication system progressed to cellular, then PCS, ROHN was again leading the market with our ROHN SSV towers serving as the industry preference for wireless sites.

ROHN continues to support wireless communication from microwave to broadband communications. Our structures are still the leaders in the industry.

ROHN also offers a variety of steel poles to meet your specific communication needs. Our tapered and flanged steel poles feature designs that are aesthetically pleasing and blend well into the environment while requiring minimum space for installation. All of our steel poles are hot-dip galvanized after fabrication to ensure years of corrosion free use. As one of the largest manufacturers of communication structures, with unmatched attention to detail and design, our steel poles provide an extremely efficient design. ROHN's steel poles meet the stringent demands of today's communication environment.



SPORTS LIGHTING SOLUTIONS



Whatever your application - from little league baseball to a major league sports stadium, ROHN has a steel pole to do the job. Poles are available with the traditional anchor base or for direct embedment. ROHN's engineering staff will select the proper pole based on your specific requirements, considering wind speed, luminaire size, weight and quantity.

For decades, ROHN has supplied sports lighting structures. ROHN towers support lights for the Anaheim Angels professional baseball team, the University of Illinois football team and the Peoria Chiefs, the local minor league baseball team near our plant location in Peoria, IL.



All poles and towers are hot-dip galvanized and our direct embed poles can be purchased with an extra subsurface corrosion resistant coating.





TRANSPORTATION SOLUTIONS



ROHN has been a trusted name in quality-engineered structures since 1948. We have the people, equipment and experience to provide the materials you need for your transportation structure projects. ROHN Mast Arms, Monotube Assemblies, Steel Strain Poles and Sign Structures are designed and manufactured to AASHTO standards. Our products can be supplied galvanized, painted over galvanizing or factory finished powder coated. We are dedicated to delivering quality products, on time at a competitive price; whether it is a single pole or multiple pole project.

ROHN has over 300,000 square feet of manufacturing located in Peoria, Illinois. ROHN's manufacturing is certified by both the American Institute of Steel Construction (Dual AISC Certified Steel Fabricator - Buildings and Simple Steel Bridges) and the Canadian Welding Bureau.

ROHN uses specialized engineering software coupled with ROHN developed software for the design of tubular structures and foundations. This allows ROHN to optimize pole designs based on customer requirements, manufacturing efficiencies and material availability. Preliminary calculation packages are sent to our customers for review with bid packages.



UTILITY SOLUTIONS



ROHN can optimize pole designs based on customer requirements, manufacturing efficiencies and material availability. Preliminary calculation packages are sent to our customers for review and approval prior to manufacturing. Fabrication and erection drawings are produced in AutoCAD and accompany the structures we produce. Our commitment to the utility industry is to provide the highest quality products with the shortest lead time.

ROHN uses Power Line Systems software coupled with ROHN developed software for the design of tubular structures and foundations. This allows us to optimize the pole designs based on customer requirements.

ROHN's state of the art equipment and facility allows us to fabricate the most difficult projects with the accuracy and reliability that you deserve. After the pole shafts have been formed on our press brake, they pass through ROHN's custom built seam welder. The shafts are then completed in one of our numerous fit-up and weld-out stations. Automation also plays a key role in the manufacturing process for latticed towers with our CNC plate processors, machining center, anglematics and beam lines that can process angle up to 8" x 8" x 1 1/4".

ROHN's Quality Assurance/Quality Control program begins when the material is received at our plant, ensuring that all material meets the designated specifications. Components are inspected and verified throughout the manufacturing process to ensure that they are within the engineering and manufacturing tolerances. All full penetration base plate and seam welds are verified with Ultrasonic Testing performed in-house by our own certified inspectors.

Because of ROHN's commitment to customer service, the Inside Sales Manager assigned to your project will work closely with you to assure your order is designed and built to the highest standards and delivered just as you ordered it. We understand the importance of on-time delivery and constantly strive to exceed your expectations. Our plant is centrally located in Peoria, Illinois, which allows for competitive freight costs.





WIND ENERGY SOLUTIONS



ROHN has extensive experience in manufacturing meteorological and turbine support structures for wind energy applications. Whatever the requirement, poles, towers or guyed masts, we have used our products to support this industry.

Our structures are used to support wind turbines ranging up to 50 kW. ROHN structures are hot-dip galvanized where the components are totally immersed in molten zinc, inside and out, to ensure years of corrosion protection. Our steel pole designs are aesthetically pleasing, while requiring minimum space for installation.



To ensure that ROHN meets the demand of today's wind energy customer, our steel poles offer extremely efficient designs and unmatched attention to detail. For over 60 years, ROHN has manufactured support structures with great care and design excellence.



UNDERSTANDING TIA-222 - REVISION G





UNDERSTANDING TIA-222 - REVISION G

What is Rev G?

Rev G is the latest revision of the TIA-222 Standard "Structural Standards for Antenna Supporting Structures and Antennas". The previous version of the Standard was Rev F. Rev G is based on a 3-second gust wind speed and Rev F is based on a fastest-mile wind speed. The wind speeds are not directly comparable and it is very important to define the basis of a wind speed when specifying wind loading requirements. For a given location, the 3-second gust wind speed represents the peak gust wind speed whereas the fastest-mile wind speed represents the average wind speed over the time required for one mile of wind to pass the site.

Rev G presents additional factors to be considered in the design of new structures and for the modification of existing structures. These factors are briefly discussed below. The reliability requirements of a structure can now be accounted for by assigning a classification to a structure (Class I, II or III). The wind speed can also be adjusted based on the type of terrain surrounding the site (Exposure B, C or D) and if the site is located on a hill, ridge or escarpment (Topographic Category 1-5).

Many tower profiles in this catalog now include antenna loading capacities for both Exposure B and Exposure C terrain conditions located on relatively flat sites (Topographic Category 1). Antenna loading capacities in accordance with Rev F are also provided for many tower profiles in the catalog. Please refer to the design notes in the catalog for each tower model series for further explanations. The Class of structure is stated in the design notes. Conditions other than stated may require a different tower profile than illustrated in this catalog. Quotes may be obtained for a specific application by contacting your ROHN representative.

Classification of Structures

Allows for the adjustment of wind, ice and earthquake loading to match the reliability requirements for a specific application. Three reliability classes have been established based on the type of service provided and on the structure's potential hazard to human life and property. Wind, ice and earthquake loading progressively increase from Class I to Class III structures.

Class I: Structures used for services where a delay in returning the service would be acceptable and the structure represents a low hazard to human life and/or property. Example services would be: residential wireless and conventional 2-way radio communications; television, radio and scanner reception; wireless cable, amateur and CB radio communications. Structures of this classification are exempt from ice and earthquake loading.

Class II: Structures used for services that may be provided by other means or structures that represent a significant hazard to human life and/or property. Example services would be: commercial wireless communications; television and radio broadcasting; cellular, PCS, CATV and microwave communications.

Class III: Structures specifically designed for essential communications or structures that represent a substantial hazard to human life and/or property. Examples of essential communications would be: civil or national defense; emergency, rescue or disaster operations; military and navigational facilities.

What is EPA?

EPA stands for Effective Projected Area. It is a standard way to define the "size" of an antenna regarding wind loading. Many antenna manufacturers provide data sheets that specify the EPA of their antennas. The TIA standard also defines a method to calculate the EPA of an antenna based on the size and type of the antenna components.

Generally, the EPA of an antenna, mount or accessory is equal to the summation of the projected areas of its components times appropriate drag factors defined in the TIA Standard. The EPA values listed in this catalog for standard tower designs represents the maximum EPA that may be supported unless otherwise indicated.

UNDERSTANDING TIA-222 - REVISION G

What is Exposure?

Exposure categories are used to adjust wind loading based on the type of terrain surrounding a site. Reduced wind loads are associated with rougher terrains that tend to slow the wind down. Three exposure categories have been defined based on terrain roughness. Wind loading is increased as the exposure designation changes from Exposure B (roughest terrain) to Exposure D (smoothest terrain).

Exposure B: Urban, suburban or wooded areas. The wind load at ground level is reduced compared to Exposure C. This reduction diminishes with height, making the overall wind reduction less significant for taller structures. In order to qualify for the wind load reduction, the rough terrain must extend in all directions from the site at least twenty times the height of the structure, but not less than one-half mile.

Exposure C: Flat, open country and grasslands.

Exposure D: Flat, unobstructed shorelines exposed to wind flowing over open water, smooth mud flats, salt flats and other similar terrain. The wind load at ground level is increased compared to Exposure C.

Topographic Categories

Topographic categories are used to determine increases in wind loading for sites located on hills and other elevated locations (other than buildings). The shape and relative height (topography) of an elevated site determines the increase in wind load. Although many elevated sites have their own unique features, the intent is to idealize these sites into one of the standard topography categories described below.

The height of an elevated site above the surrounding terrain must be specified in order to determine the increase in wind loading. Height should not be confused with the elevation of the site. As described below, elevations of the site and the surrounding terrain must be used to determine the relative height of a site. For structures supported on buildings, it is only necessary to specify the height of the building and the surrounding exposure category.

Category 1: Flat or rolling terrain with no abrupt changes in general topography. No increase in wind loading is required for this category.

Category 2: Sites separated from a lower elevation by a gently sloping terrain (escarpment). Wind loads at the crest are 2.0 times the wind loads for a flat site and diminish with height depending on the height of the escarpment.

Height for an escarpment is the difference in elevation between the upper and lower levels. Increased wind loads do not apply for structures located in the lower half of the sloping terrain or located beyond 16 times the escarpment's height from the crest.

Category 3: Sites located at the top or within the upper half of a hill. Wind loads at the top of a hill are 2.3 times the wind loads for a flat site and diminish with height depending on the relative height of the hill.

Height for a hill is the difference in elevation between the top and bottom of the hill. For sites surrounded by other hills, height is the difference in the hill elevation at the site and the average elevation of the surrounding hills (within a 2-mile radius). In other words, height is the projection of the hill exposed to wind. When there are other hills surrounding the site, increased wind loads do not apply unless the height of the hill at the tower site is at least 2 times the average height of the surrounding hills. (Refer to sketch above.)

Topographic Categories continued on next page.



UNDERSTANDING TIA-222 - REVISION G

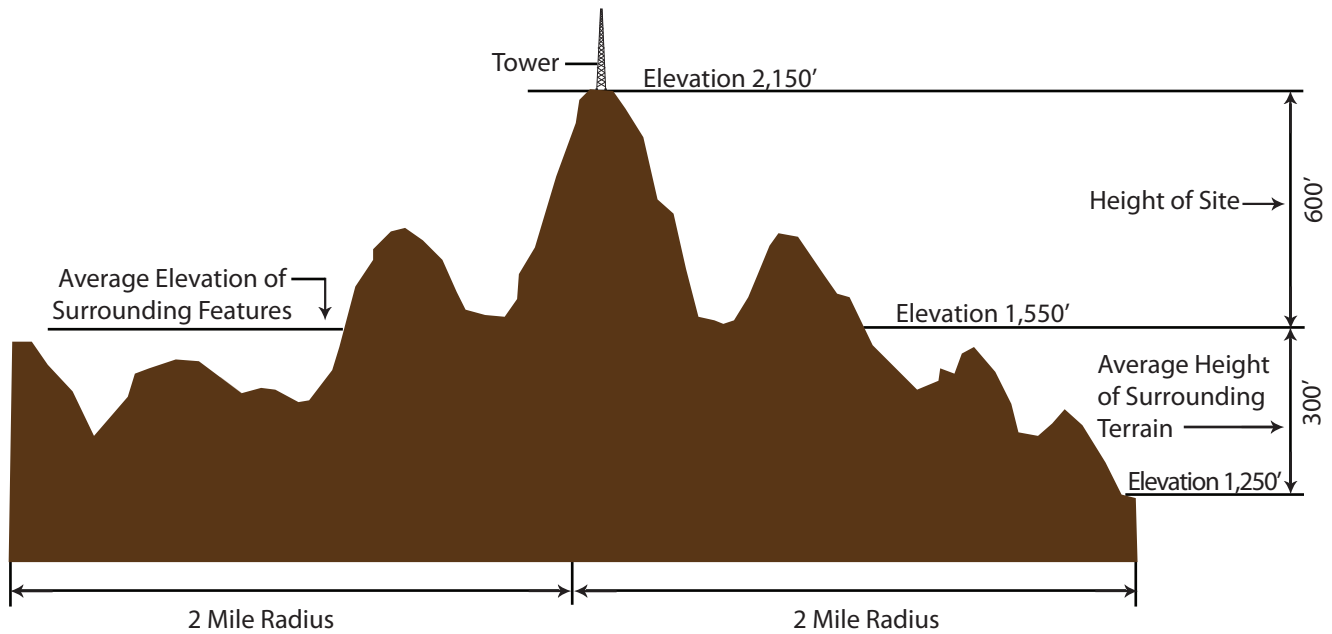

$$H = 2,150' - 1,550' = 600'$$

Wind speed-up must be considered when H exceeds 2 times the average height of surrounding features.

Category 4: Sites located on a ridge. Wind loads at the top of a ridge are 3 times the wind loads for a flat site and diminish with height depending on the height of the ridge.

Height for a ridge is the difference between the top and bottom elevations of the ridge.

Category 5: This category is reserved for sites where site-specific investigations are performed to determine wind loading. A site-specific investigation may result in either higher or lower wind loads compared to using one of the standard topographic categories.



REV G 3-SECOND BASIC WIND SPEED MAP

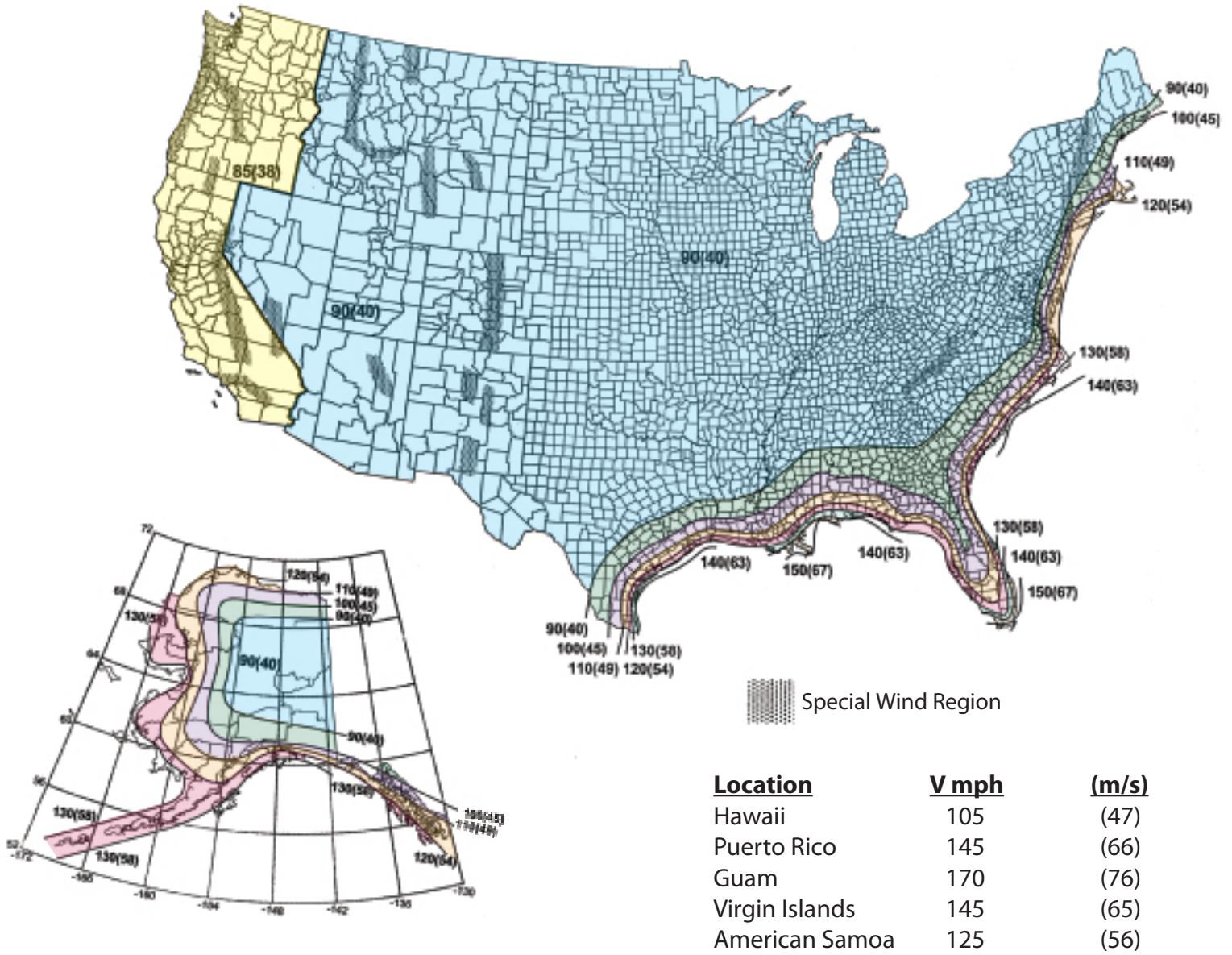

Notes:

1. Values are 3-second gust wind speeds in miles per hour (m/s) at 33 ft. (10 m) above ground for Exposure C terrain.
2. Linear interpolation between wind contours is permitted.
3. Islands and coastal areas outside last contour must use the last wind speed contour of the coastal area.
4. Mountainous terrain, gorges, ocean promontories, and special wind regions must be examined for unusual wind conditions.

The basic wind speed map is being used with permission from ASCE. This material may be used for personal use only. Any other use requires prior permission of the American Society of Civil Engineers.



REV G WIND SPEEDS

The TIA-222-G Standard is based on the wind map published in the ASCE 7-02 Standard, "Minimum Design Loads for Buildings and Other Standards". The ASCE 7 standard is published by the American Society of Civil Engineers (ASCE) and represents the latest research and data available for wind speeds in the United States.

Subsequent to the release of the TIA-222-G Standard, ASCE has published 2 revisions to the ASCE-7 Standard. The first revision was published in 2005 and is designated as ASCE 7-05. There were no changes to the wind map. The second revision was published in 2010 and is designated as ASCE 7-10. There are changes to the wind map in this version.

The previous versions of ASCE 7 used a 50-year return wind speed map and relied on additional design factors to increase wind loads according to the reliability requirements of a structure. This resulted in structures being able to survive wind speeds of much higher return periods. The new wind maps in ASCE 7-10 now include these design factors and now represent a much higher return period wind speed. A wind map is provided for each classification of structure. No additional factors have to be considered based on the classification of a structure when these wind speeds are used to calculate wind loads. The new maps can be thought of as "Factored" wind speeds, or in other words, wind speeds for which permanent deformation may occur in a structure, but the structure does not collapse.

The new ASCE 7-10 factored wind speeds can be easily converted for use with the TIA-222-G Standard using the following conversion table. If the conversion is not made, the design factors for determining wind loads will be "doubled up" resulting in much higher wind loads than intended. Eventually the TIA Standard and other similar structural standards will be upgraded to reflect the new ASCE 7-10 wind maps. Conversions for fastest-mile wind speeds used in Rev F and ASCE 7-93 are also included in the table.

Design Wind Speed Conversions, MPH

Rev F ASCE 7-93 (fastest-mile)	Rev G ASCE 7-02 & ASCE 7-05 (3-second gust)	Factored ASCE 7-10 (3-second gust)
71	85	110
76	90	115
85	100	126
90	105	133
95	110	139
104	120	152
114	130	164
123	140	177
128	145	183
133	150	190
152	170	215

Examples to determine appropriate Rev G design criteria:

1. Desire a 95 mph Rev F fastest-mile design. Use a 110 mph Rev G design.
2. Desire a 115 mph ASCE 7-10 design. Use a 90 mph Rev G design.

REV G GROUNDING REQUIREMENT FOR STRUCTURES

Rev G made significant changes regarding the grounding requirements for structures. A prescriptive approach to grounding was used in Rev F where providing specific grounding leads and ground rods were considered adequate to protect a structure. Rev G adopted a performance specification approach that requires providing a grounding system that will result in a maximum 10 ohm resistance to earth. Rev G also requires minimum ground lead and ground rod sizes that are greater than the Rev F prescriptive requirements.

Another change is that Rev G does not require specific grounding materials. Rev F required the use of galvanized ground rods with tinned copper leads. Rev G only requires that the leads and connections be compatible with the ground rods from a corrosion standpoint (i.e. minimize difference between metals connected).

Rev G does provide default grounding arrangements for various types of structures that are intended to meet the 10 ohm requirement for a wide variety of soil conditions. In accordance with Rev G, the actual resistance of a default grounding system must be verified based on site conditions. Additional ground rods or special grounding systems may be required.

It should be noted that the TIA-222 grounding requirements are meant to protect the structure and foundation from high fault currents. Other grounding requirements are often needed for the protection of antennas, radio equipment and other appurtenances.

REV G STANDARD FOUNDATIONS

Rev G has taken a different approach from Rev F regarding standard foundations and the term "Normal Soil" has been eliminated. A new term "Presumptive Soil" has been introduced. Rev G provides for two different types of presumptive soil, sand and clay. Generally the strength of Rev G presumptive soil is lower than the strength of Rev F normal soil.

The intent is to provide default design parameters that can be used to design foundations when a geotechnical report is not available for a site. In accordance with Rev G, clay is to be considered the default presumptive soil unless more information is known about a site. The values for clay presumptive soil have therefore been used for the generation of the standard foundations contained in this catalog.

It should be noted that in accordance with Rev G, actual site conditions must be investigated prior to the installation of a foundation that was designed using presumptive soil parameters. Modifications to the standard foundations contained in this catalog may be required. It should also be noted that Rev G requires a geotechnical investigation for all Class III structures.

One common cause for changes to a standard foundation is due to frost depth. The frost depth for Rev G presumptive soil is considered to be 3.5 feet. The standard foundations in this catalog are based on this frost depth. Special foundations may be required for sites in locations where frost depths exceed 3.5 feet and the local soil conditions are susceptible to frost heave.

Presumptive soil also assumes that the water table is below the foundation depth. For this condition, there is no concern for buoyant conditions that can significantly reduce the uplift capacity of a foundation. The standard foundations in this catalog are based on dry soil conditions and do not consider buoyant conditions. Special foundations may be required for sites where the water table may rise above the base elevation of the foundation.

In accordance with Rev G, presumptive soils are also considered to be non-corrosive. When local soil conditions are corrosive, anchors or direct embedded poles that are in direct soil contact may require corrosion protection in addition to hot dip galvanizing. Rev G provides guidance on various alternatives to consider in these situations.

Presumptive soils are also considered to be non-expansive. Locations known to have expansive soil require special considerations for foundation design. Modifications to the standard foundations in this catalog may be required in these cases.



REV G CLIMBING FACILITIES

Rev G has made significant additions addressing climber safety. Two classifications of climbers have been defined. An Authorized Climber (also called a Basic Climber) is an individual trained in climbing but may not have had previous climbing experience. These climbers are intended to be limited to climbing fixed access routes equipped with safety climb devices. A Competent Climber (also called a Skilled Climber) is a professional who is capable of climbing on structural members.

Rev G provides requirements for climbing facilities by defining two classes of climbing facilities, Class A and Class B. Class B requirements are similar to Rev F requirements and are intended for structures to be climbed by professional Competent Climbers. Class A requirements are more restrictive in comparison to Rev F and are intended for structures expected to be climbed by lesser qualified (Basic) climbers. In accordance with Rev G, Class B is considered to be the default climbing facility requirement for structures unless otherwise specified. Towers can be quoted to accommodate Class A climbing facilities when specified. All ROHN standard structures are intended to be climbed by Competent Climbers only.

Safety climb systems are now mandatory in accordance with Rev G for structures exceeding 10 feet in height that are intended to be climbed. Some structures are intended to be maintained by bucket trucks or other methods that do not involve climbing the structure. Safety climb systems, when required, must be ordered separately for all ROHN standard structures in this catalog.

GUYED TOWERS

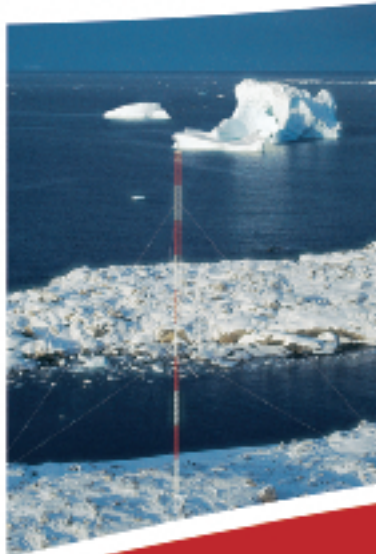



ROHN began manufacturing the G-Series line of towers in the early 1950's. Starting with the ROHN No. 5 tower, there was an ever present drive for a superior tower design. The No. 5 soon led to the ROHN No. 6 and continued through the No.10, 11, 20, 25, 30, 40 and 50 towers. ROHN originally coated the lightweight towers with a hot-dipped enamel coating called RohnKote. The alternative to RohnKote was hot-dipped galvanizing. The galvanized option was identified by the now famous "G" suffix added to the tower model. The G-Series was born! The numbers have settled to the four models listed below and hot-dip galvanizing is the coating of choice for towers today.

ROHN's G-Series towers are designed for strength and versatility. The towers are constructed with high strength steel tubing or solid round legs. ROHN's exclusive Zig-Zag solid-rod bracing provides exceptional strength. As they were in the 1950's, each ROHN G-Series tower continues to be hot-dip galvanized for corrosion protection.

25G | 45G | 55G | 65G

The 25G is a light weight tubular tower with solid braces. The tower sections are most often guyed, but can also be used in bracketed and self-supporting applications. Standard sections are 10' in length, but are also available in a 7' length, which is UPS shippable. This tower model has several top options, as well as a variety of tower accessories. The 25G has several base options, including: base cast in concrete, base plate with anchor bolts and also a hinged base.

Standard Design Tower Heights

- Guyed: Up to 190'
- Bracketed: Up to 100'
- Self-Supporting: Up to 40'



25G | 45G | 55G | 65G

The 45G is a light weight tower, available with tubular or solid round legs with solid braces. The tower sections are most often guyed, but can also be used in bracketed and self-supporting applications. Standard sections are 10' in length, but are also available in a 20' length when ordering solid sections. This tower model has several top options, as well as a variety of tower accessories. The 45G has several base options, including: base cast in concrete, base plate with anchor bolts and also a hinged base. This tower is a true multi-use structure.

Standard Design Tower Heights

- Guyed: Up to 300' [45G] and 350' [45GSR]
- Bracketed: Up to 100'
- Self-Supporting: Up to 45'



25G | 45G | **55G** | 65G

The 55G is a tubular tower with solid braces that lends itself to a wide variety of uses, particularly where unusual wind loading and height requirements exist. The 55G was designed to provide excellent strength and rigidity. The tower sections are most often guyed, but can also be used in bracketed and self-supporting applications. Standard sections are 10' in length. This tower model has several top options, as well as a variety of tower accessories. The 55G is available with a base cast in concrete as well as a tapered base option.

Standard Design Tower Heights

Guyed: Up to 400'

Bracketed: Up to 100'

Self-Supporting: Up to 60'



25G | 45G | 55G | **65G**

The 65G is available with tubular or solid round legs with solid braces. The tower sections are most often guyed, but can also be used in self-supporting applications. Standard sections are 10' and 20' in length. This tower model has a variety of tower accessories, and is available with a base cast in concrete or a tapered base.

Standard Design Tower Heights

Guyed: Up to 500'

Self-Supporting: Up to 80'



The ROHN G-Series towers are assembled and installed quickly and are diverse enough for use by broadcasters, fire and police, military, ham and home use. The possibilities are endless with the G-Series towers. Over the long history of the G-Series, ROHN has developed a variety of options to improve the utility of each model. The G-Series has optional:

- Standard and Shortened Sections
- Guy Lug Sections
- Four Leg (Square) Design of 25G
- Double Braced Sections
- Double Braced Sections
- Torque Arms
- Roof Mounts
- Top Mounts
- House Brackets
- Base Options
- Side Arms



STANDARD 25G GUYED TOWER

ROHN 25G
The first. The original.



25G

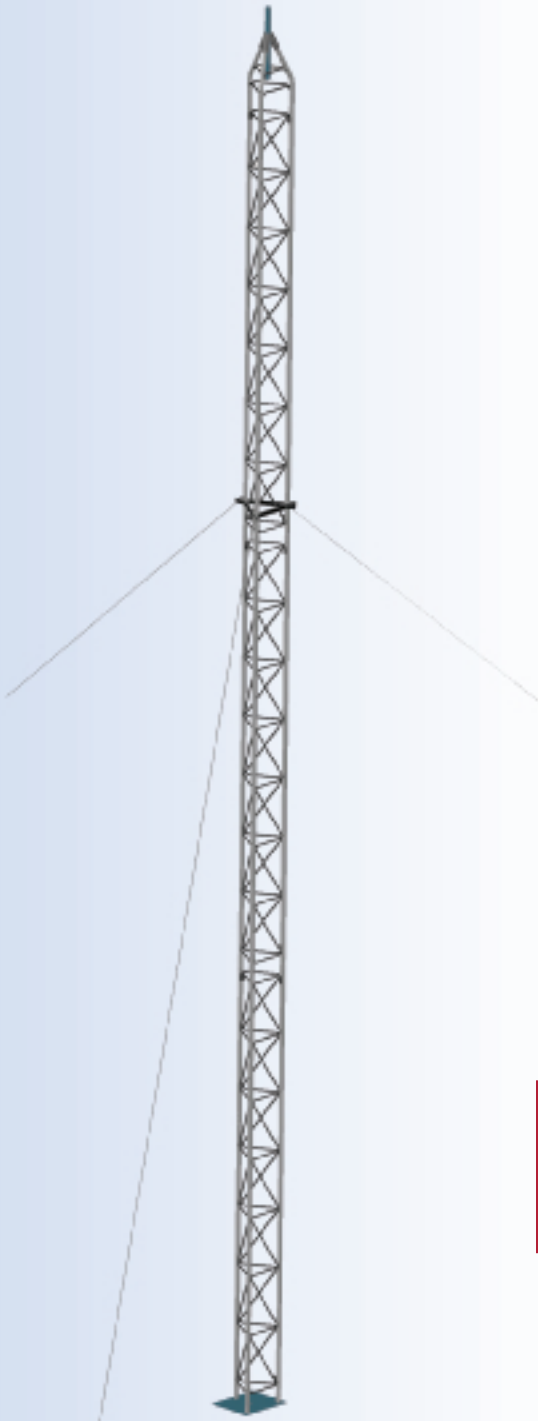

GENERAL USE

The 25G is available in the standard 10' section length and a 7' length which is UPS shippable. The 25G uses double bolted joints, proven to be the best method of joining tower sections for sturdiness and dependability. As a guyed structure, the 25G standard designs rise to a height of 190'.

FEATURES

- Completely hot-dip galvanized after fabrication
- Built on an 11 1/4" equilateral triangle design
- High strength tubular legs joined by Zig-Zag[®] cross members
- Each 7' or 10' section contains all required nuts and bolts shipped with section
- Continuous solid round steel bracing

CAUTION

Mixing copies of ROHN towers with ROHN towers is dangerous and voids all engineering and warranty data supplied by ROHN. Materials used by others are not the same quality and have not been tested or engineered by ROHN. Mixing ROHN tower sections with non-ROHN products may cause tower failure or injury.

Per Rev G requirements, any structure greater than 10' requires a climber safety device. Please see page 40 for ordering information.



STANDARD 25G GUYED TOWER SECTIONS

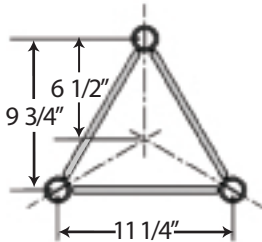

QUICK REFERENCE

PARTS & ACCESSORIES	PAGES 37-40
GROUNDING INFORMATION	PAGE 41
FOUNDATION INFORMATION	PAGES 41-44

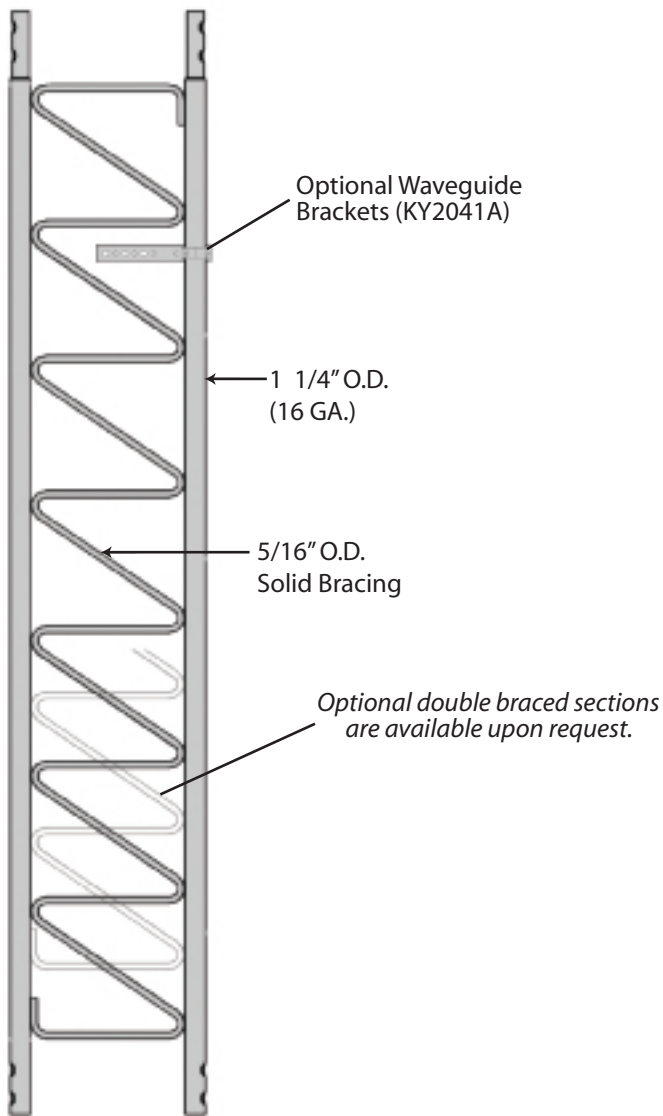

STANDARD SECTION
25G - 10' Section

OPTIONAL 7' SECTION
25G7 - 7' Section

The 7' Section is UPS shippable.

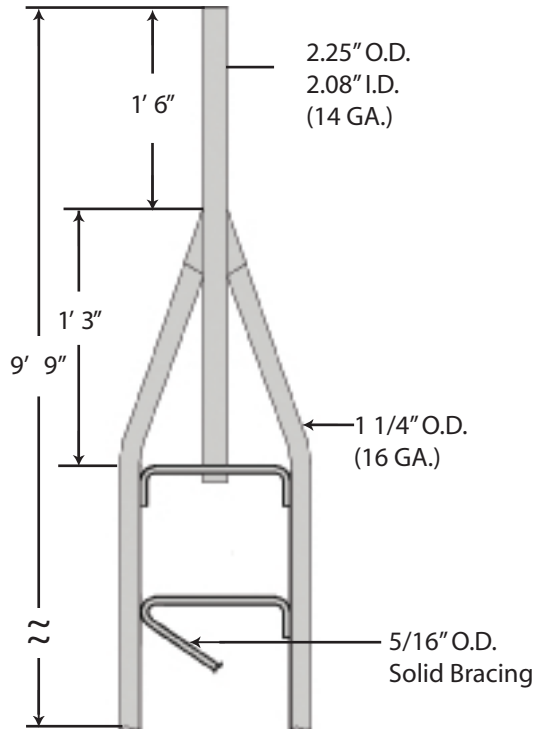

STANDARD TOP SECTION
25AG2

Additional 25G top sections are shown on page 37.

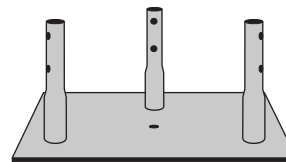

CONCRETE BASE PLATE
BPC25G*

FOR USE WITH 3/4X12PP PIER PIN
EMBEDDED IN CONCRETE.

Additional base sections are available, please see page 38.

* Towers mounted on these bases must be bracketed or guyed at all times. Temporary steel guying may also be necessary during installation and dismantling.



**BUYERS GUIDE
STANDARD DESIGNS - 25G
90MPH REV. G [3-SECOND GUST]
70MPH REV. F [FASTEST MILE]**

Design Criteria

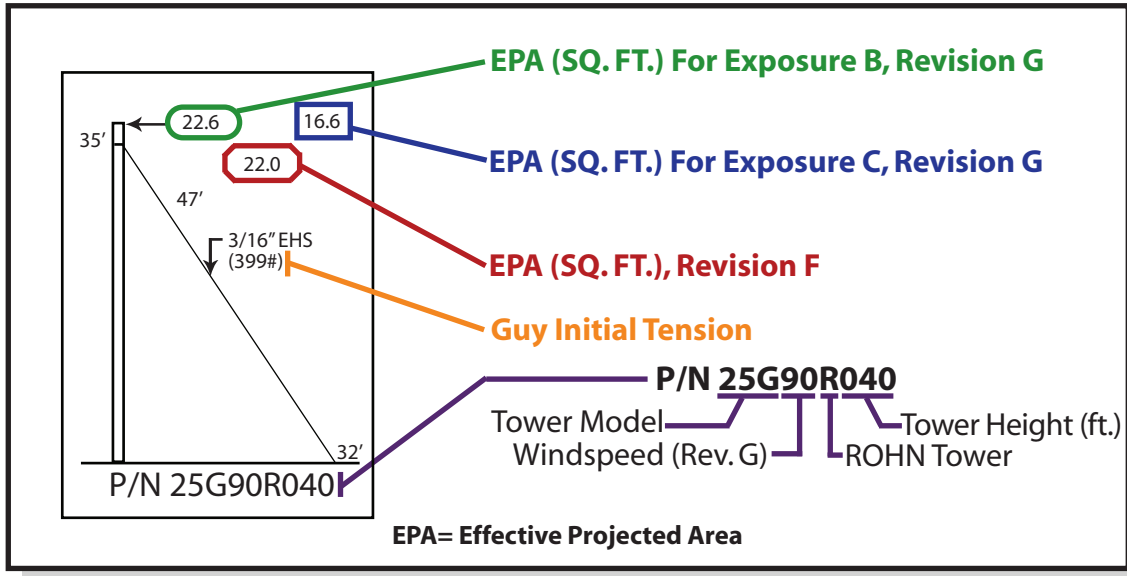

This document is to serve as a guide for sizing and purchasing the 25G tower. Tower and foundation installations should be performed by qualified and experienced personnel using assembly drawings provided with each tower.

DESIGN NOTES:

1. Tower designs are in accordance with ANSI/TIA-222-F and ANSI/TIA-222-G, Class I Structures, Topographic Category 1.
2. Design assumes towers are installed on level ground. Lower EPA values will apply for roof mounted towers or for sites located on unusual terrain.
3. Designs assume two 1/2" diameter lines on each tower face.
4. Anchor radius is from tower base to intersection of anchor rod with ground.
5. Guy chord lengths shown are based on level ground. Initial tensions for guys are shown in () in pounds at 60° Fahrenheit.
6. Antenna and mounts are assumed symmetrically placed at the tower top.

PARTS LIST NOTES:

1. Items listed are required for complete guyed towers.
2. Base and anchor foundations listed refer to standard foundation designations.
3. Guys provided with each standard tower are based on level ground conditions with an additional 6% length.
4. Rev G anchor grounding (AGK1GGX) and base grounding (BGK3GGX) are included with the tower material.
5. Assembly drawings and a safety package (P/N: ACWS) are included with each tower.
6. Parts lists are subject to change based on availability or revised design criteria.

**FOR FOUNDATION INFORMATION, PLEASE SEE PAGES 41-44.
FOR GENERAL INSTALLATION INFORMATION, PLEASE SEE PAGES 147-153.**



STANDARD DESIGN - 25G

90MPH REV. G, 70MPH REV. F

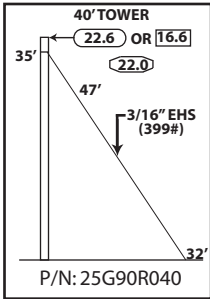

TOWER PARTS INCLUDED	25G	25AG2	BPC25G	GA25GD	FDNS	
					BASE	ANCHOR
	3	1	1	1	CB1G	AB2
GUYS & CONNECTIONS INCLUDED	3/16EHS	BG2142	5/16THH	1/2TBE&J	TBSAFETY	
	175'	6	6	3	3	
ANCHORS & GROUNDING INCLUDED	GAC3455TOP	AGK1GGX	BGK3GGX	CPC.5/.75	3/4x12PP	
	3	1	3	3	1	

40' ROHN 25G
All parts shown in table are included when ordering
Part No: 25G90R040

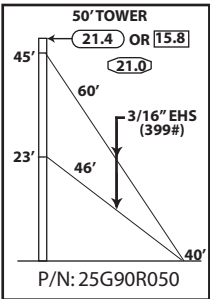

TOWER PARTS INCLUDED	25G	25AG2	BPC25G	GA25GD	FDNS	
					BASE	ANCHOR
	4	1	1	2	CB1G	AB2
GUYS & CONNECTIONS INCLUDED	3/16EHS	BG2142	5/16THH	1/2TBE&J	TBSAFETY	
	350'	12	12	6	3	
ANCHORS & GROUNDING INCLUDED	GAC3455TOP	AGK1GGX	BGK3GGX	CPC.5/.75	3/4x12PP	
	3	1	3	3	1	

50' ROHN 25G
All parts shown in table are included when ordering
Part No: 25G90R050

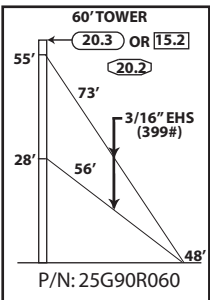

TOWER PARTS INCLUDED	25G	25AG2	BPC25G	GA25GD	FDNS	
					BASE	ANCHOR
	5	1	1	2	CB1G	AB2
GUYS & CONNECTIONS INCLUDED	3/16EHS	BG2142	5/16THH	1/2TBE&J	TBSAFETY	
	425'	12	12	6	3	
ANCHORS & GROUNDING INCLUDED	GAC3455TOP	AGK1GGX	BGK3GGX	CPC.5/.75	3/4x12PP	
	3	1	3	3	1	

60' ROHN 25G
All parts shown in table are included when ordering
Part No: 25G90R060

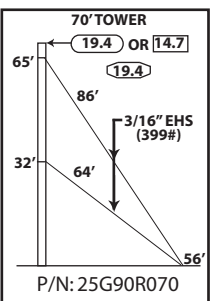

TOWER PARTS INCLUDED	25G	25AG2	BPC25G	GA25GD	FDNS	
					BASE	ANCHOR
	6	1	1	2	CB1G	AB2
GUYS & CONNECTIONS INCLUDED	3/16EHS	BG2142	5/16THH	1/2TBE&J	TBSAFETY	
	500'	12	12	6	3	
ANCHORS & GROUNDING INCLUDED	GAC3455TOP	AGK1GGX	BGK3GGX	CPC.5/.75	3/4x12PP	
	3	1	3	3	1	

70' ROHN 25G
All parts shown in table are included when ordering
Part No: 25G90R070

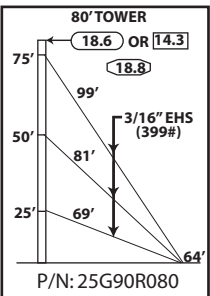

TOWER PARTS INCLUDED	25G	25AG2	BPC25G	GA25GD	FDNS	
					BASE	ANCHOR
	7	1	1	3	CB1G	AB2
GUYS & CONNECTIONS INCLUDED	3/16EHS	BG2142	5/16THH	1/2TBE&J	TBSAFETY	
	800'	18	18	9	3	
ANCHORS & GROUNDING INCLUDED	GAC3455TOP	AGK1GGX	BGK3GGX	CPC.5/.75	3/4x12PP	
	3	1	3	3	1	

80' ROHN 25G
All parts shown in table are included when ordering
Part No: 25G90R080



STANDARD DESIGN - 25G
90MPH REV. G, 70MPH REV. F

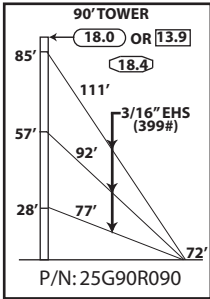

TOWER PARTS INCLUDED	25G	25AG2	BPC25G	GA25GD	FDNS	
					BASE	ANCHOR
	8	1	1	3	CB1G	AB2
GUYS & CONNECTIONS INCLUDED	3/16EHS	BG2142	5/16THH	1/2TBE&J	TBSAFETY	
	900'	18	18	9	3	
ANCHORS & GROUNDING INCLUDED	GAC3455TOP	AGK1GGX	BGK3GGX	CPC.5/.75	3/4x12PP	
	3	1	3	3	1	

90' ROHN 25G
All parts shown in table are included when ordering
Part No: 25G90R090

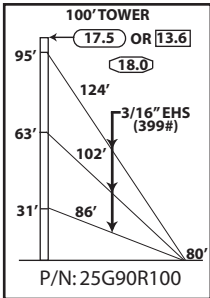

TOWER PARTS INCLUDED	25G	25AG2	BPC25G	GA25GD	FDNS	
					BASE	ANCHOR
	9	1	1	3	CB1G	AB2
GUYS & CONNECTIONS INCLUDED	3/16EHS	BG2142	5/16THH	1/2TBE&J	TBSAFETY	
	1000'	18	18	9	3	
ANCHORS & GROUNDING INCLUDED	GAC3455TOP	AGK1GGX	BGK3GGX	CPC.5/.75	3/4x12PP	
	3	1	3	3	1	

100' ROHN 25G
All parts shown in table are included when ordering
Part No: 2590R100

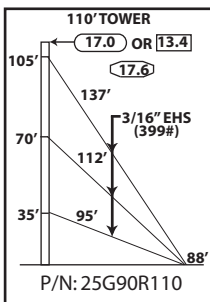

TOWER PARTS INCLUDED	25G	25AG2	BPC25G	GA25GD	FDNS	
					BASE	ANCHOR
	10	1	1	3	CB1G	AB2
GUYS & CONNECTIONS INCLUDED	3/16EHS	BG2142	5/16THH	1/2TBE&J	TBSAFETY	
	1100'	18	18	9	3	
ANCHORS & GROUNDING INCLUDED	GAC3455TOP	AGK1GGX	BGK3GGX	CPC.5/.75	3/4x12PP	
	3	1	3	3	1	

110' ROHN 25G
All parts shown in table are included when ordering
Part No: 25G90R110

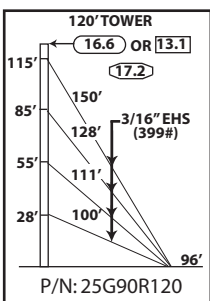

TOWER PARTS INCLUDED	25G	25AG2	BPC25G	GA25GD	FDNS	
					BASE	ANCHOR
	11	1	1	4	CB1G	AB2
GUYS & CONNECTIONS INCLUDED	3/16EHS	BG2142	5/16THH	1/2TBE&J	TBSAFETY	
	1575'	24	24	12	3	
ANCHORS & GROUNDING INCLUDED	GAC3455TOP	AGK1GGX	BGK3GGX	CPC.5/.75	3/4x12PP	
	3	1	3	3	1	

120' ROHN 25G
All parts shown in table are included when ordering
Part No: 25G90R120

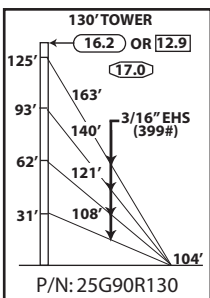

TOWER PARTS INCLUDED	25G	25AG2	BPC25G	GA25GD	FDNS	
					BASE	ANCHOR
	12	1	1	4	CB1G	AB2
GUYS & CONNECTIONS INCLUDED	3/16EHS	BG2142	5/16THH	1/2TBE&J	TBSAFETY	
	1700'	24	24	12	3	
ANCHORS & GROUNDING INCLUDED	GAC3455TOP	AGK1GGX	BGK3GGX	CPC.5/.75	3/4x12PP	
	3	1	3	3	1	

130' ROHN 25G
All parts shown in table are included when ordering
Part No: 25G90R130



STANDARD DESIGN - 25G 90MPH REV. G, 70MPH REV. F

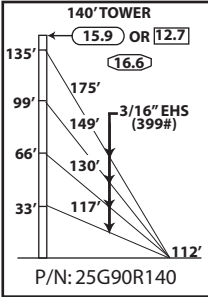

TOWER PARTS INCLUDED	25G	25AG2	BPC25G	GA25GD	FDNS	
					BASE	ANCHOR
	13	1	1	4	CB1G	AB2
GUYS & CONNECTIONS INCLUDED	3/16EHS	BG2142	5/16THH	1/2TBE&J	TBSAFETY	
	1825'	24	24	12	3	
ANCHORS & GROUNDING INCLUDED	GAC3455TOP	AGK1GGX	BGK3GGX	CPC.5/.75	3/4x12PP	
	3	1	3	3	1	

140' ROHN 25G
All parts shown in table are included when ordering
Part No: 25G90R140

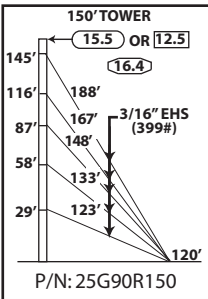

TOWER PARTS INCLUDED	25G	25AG2	BPC25G	GA25GD	FDNS	
					BASE	ANCHOR
	14	1	1	5	CB1G	AB2
GUYS & CONNECTIONS INCLUDED	3/16EHS	BG2142	5/16THH	1/2TBE&J	TBSAFETY	
	2425'	30	30	15	3	
ANCHORS & GROUNDING INCLUDED	GAC3455TOP	AGK1GGX	BGK3GGX	CPC.5/.75	3/4x12PP	
	3	1	3	3	1	

150' ROHN 25G
All parts shown in table are included when ordering
Part No: 25G90R150

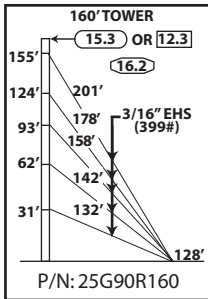

TOWER PARTS INCLUDED	25G	25AG2	BPC25G	GA25GD	FDNS	
					BASE	ANCHOR
	15	1	1	5	CB1G	AB2
GUYS & CONNECTIONS INCLUDED	3/16EHS	BG2142	5/16THH	1/2TBE&J	TBSAFETY	
	2600'	30	30	15	3	
ANCHORS & GROUNDING INCLUDED	GAC3455TOP	AGK1GGX	BGK3GGX	CPC.5/.75	3/4x12PP	
	3	1	3	3	1	

160' ROHN 25G
All parts shown in table are included when ordering
Part No: 25G90R160

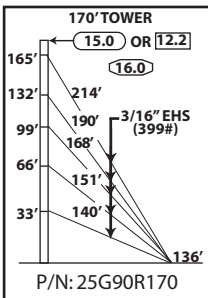

TOWER PARTS INCLUDED	25G	25AG2	BPC25G	GA25GD	FDNS	
					BASE	ANCHOR
	16	1	1	5	CB1G	AB2
GUYS & CONNECTIONS INCLUDED	3/16EHS	BG2142	5/16THH	1/2TBE&J	TBSAFETY	
	2750'	30	30	15	3	
ANCHORS & GROUNDING INCLUDED	GAC3455TOP	AGK1GGX	BGK3GGX	CPC.5/.75	3/4x12PP	
	3	1	3	3	1	

170' ROHN 25G
All parts shown in table are included when ordering
Part No: 25G90R170

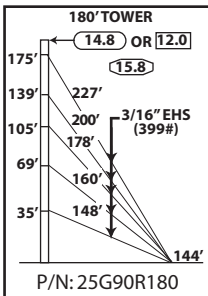

TOWER PARTS INCLUDED	25G	25AG2	BPC25G	GA25GD	FDNS	
					BASE	ANCHOR
	17	1	1	5	CB1G	AB2
GUYS & CONNECTIONS INCLUDED	3/16EHS	BG2142	5/16THH	1/2TBE&J	TBSAFETY	
	2925'	30	30	15	3	
ANCHORS & GROUNDING INCLUDED	GAC3455TOP	AGK1GGX	BGK3GGX	CPC.5/.75	3/4x12PP	
	3	1	3	3	1	

180' ROHN 25G
All parts shown in table are included when ordering
Part No: 25G90R180



STANDARD DESIGN - 25G
 90MPH REV. G, 70MPH REV. F

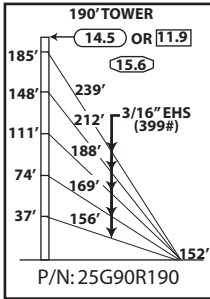

TOWER PARTS INCLUDED	25G	25AG2	BPC25G	GA25GD	FDNS	
					BASE	ANCHOR
	18	1	1	5	CB1G	AB2
GUYS & CONNECTIONS INCLUDED	3/16EHS	BG2142	5/16THH	1/2TBE&J	TBSAFETY	
	3075'	30	30	15	3	
ANCHORS & GROUNDING INCLUDED	GAC3455TOP	AGK1GGX	BGK3GGX	CPC.5/.75	3/4x12PP	
	3	1	3	3	1	

190' ROHN 25G
 All parts shown in table are included when ordering
 Part No: 25G90R190



STANDARD DESIGN - 25G

110MPH REV. G, 90MPH REV. F

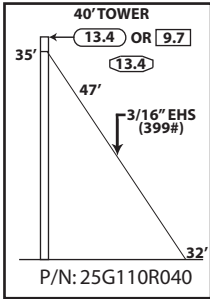

TOWER PARTS INCLUDED	25G	25AG2	BPC25G	GA25GD	FDNS	
					BASE	ANCHOR
	3	1	1	1	CB1G	AB2
GUYS & CONNECTIONS INCLUDED	3/16EHS	BG2142	5/16THH	1/2TBE&J	TBSAFETY	
	175'	6	6	3	3	
ANCHORS & GROUNDING INCLUDED	GAC3455TOP	AGK1GGX	BGK3GGX	CPC.5/.75	3/4x12PP	
	3	1	3	3	1	

40' ROHN 25G
All parts shown in table are included when ordering Part No: 25G110R040

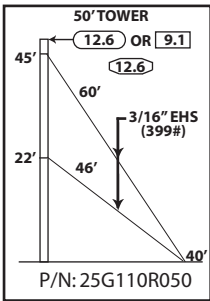

TOWER PARTS INCLUDED	25G	25AG2	BPC25G	GA25GD	FDNS	
					BASE	ANCHOR
	4	1	1	2	CB1G	AB2
GUYS & CONNECTIONS INCLUDED	3/16EHS	BG2142	5/16THH	1/2TBE&J	TBSAFETY	
	350'	12	12	6	3	
ANCHORS & GROUNDING INCLUDED	GAC3455TOP	AGK1GGX	BGK3GGX	CPC.5/.75	3/4x12PP	
	3	1	3	3	1	

50' ROHN 25G
All parts shown in table are included when ordering Part No: 25G110R050

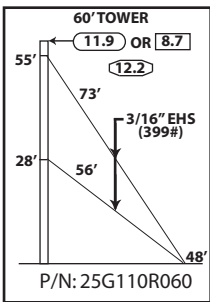

TOWER PARTS INCLUDED	25G	25AG2	BPC25G	GA25GD	FDNS	
					BASE	ANCHOR
	5	1	1	2	CB1G	AB2
GUYS & CONNECTIONS INCLUDED	3/16EHS	BG2142	5/16THH	1/2TBE&J	TBSAFETY	
	425'	12	12	6	3	
ANCHORS & GROUNDING INCLUDED	GAC3455TOP	AGK1GGX	BGK3GGX	CPC.5/.75	3/4x12PP	
	3	1	3	3	1	

60' ROHN 25G
All parts shown in table are included when ordering Part No: 25G110R060

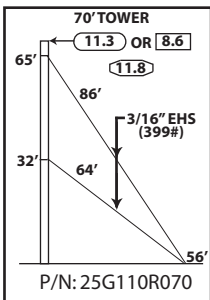

TOWER PARTS INCLUDED	25G	25AG2	BPC25G	GA25GD	FDNS	
					BASE	ANCHOR
	6	1	1	2	CB1G	AB2
GUYS & CONNECTIONS INCLUDED	3/16EHS	BG2142	5/16THH	1/2TBE&J	TBSAFETY	
	500'	12	12	6	3	
ANCHORS & GROUNDING INCLUDED	GAC3455TOP	AGK1GGX	BGK3GGX	CPC.5/.75	3/4x12PP	
	3	1	3	3	1	

70' ROHN 25G
All parts shown in table are included when ordering Part No: 25G110R070

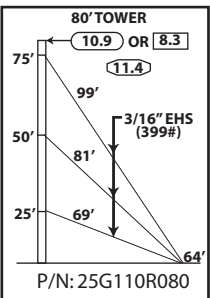

TOWER PARTS INCLUDED	25G	25AG2	BPC25G	GA25GD	FDNS	
					BASE	ANCHOR
	7	1	1	3	CB1G	AB2
GUYS & CONNECTIONS INCLUDED	3/16 EHS	BG2142	5/16 THH	1/2TBE&J	TBSAFETY	
	800'	18	18	9	3	
ANCHORS & GROUNDING INCLUDED	GAC3455TOP	AGK1GGX	BGK3GGX	CPC.5/.75	3/4x12PP	
	3	1	3	3	1	

80' ROHN 25G
All parts shown in table are included when ordering Part No: 25G110R080



STANDARD DESIGN - 25G
110MPH REV. G, 90MPH REV. F

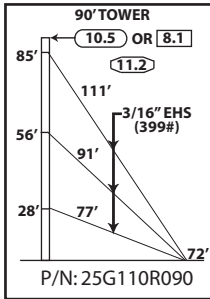

TOWER PARTS INCLUDED	25G	25AG2	BPC25G	GA25GD	FDNS	
					BASE	ANCHOR
	8	1	1	3	CB1G	AB2
GUYS & CONNECTIONS INCLUDED	3/16EHS	BG2142	5/16THH	1/2TBE&J	TBSAFETY	
	900'	18	18	9	3	
ANCHORS & GROUNDING INCLUDED	GAC3455TOP	AGK1GGX	BGK3GGX	CPC.5/.75	3/4x12PP	
	3	1	3	3	1	

90' ROHN 25G
 All parts shown in table are included when ordering
 Part No: 25G110R090

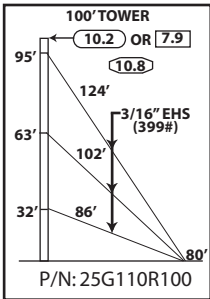

TOWER PARTS INCLUDED	25G	25AG2	BPC25G	GA25GD	FDNS	
					BASE	ANCHOR
	9	1	1	3	CB1G	AB2
GUYS & CONNECTIONS INCLUDED	3/16EHS	BG2142	5/16THH	1/2TBE&J	TBSAFETY	
	1000'	18	18	9	3	
ANCHORS & GROUNDING INCLUDED	GAC3455TOP	AGK1GGX	BGK3GGX	CPC.5/.75	3/4x12PP	
	3	1	3	3	1	

100' ROHN 25G
 All parts shown in table are included when ordering
 Part No: 25G110R100

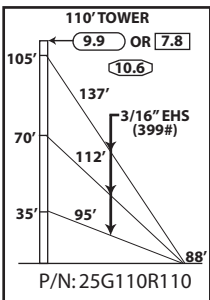

TOWER PARTS INCLUDED	25G	25AG2	BPC25G	GA25GD	FDNS	
					BASE	ANCHOR
	10	1	1	3	CB1G	AB2
GUYS & CONNECTIONS INCLUDED	3/16EHS	BG2142	5/16THH	1/2TBE&J	TBSAFETY	
	1100'	18	18	9	3	
ANCHORS & GROUNDING INCLUDED	GAC3455TOP	AGK1GGX	BGK3GGX	CPC.5/.75	3/4x12PP	
	3	1	3	3	1	

110' ROHN 25G
 All parts shown in table are included when ordering
 Part No: 25G110R110

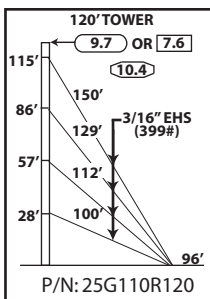

TOWER PARTS INCLUDED	25G	25AG2	BPC25G	GA25GD	FDNS	
					BASE	ANCHOR
	11	1	1	4	CB1G	AB2
GUYS & CONNECTIONS INCLUDED	3/16EHS	BG2142	5/16THH	1/2TBE&J	TBSAFETY	
	1575'	24	24	12	3	
ANCHORS & GROUNDING INCLUDED	GAC3455TOP	AGK1GGX	BGK3GGX	CPC.5/.75	3/4x12PP	
	3	1	3	3	1	

120' ROHN 25G
 All parts shown in table are included when ordering
 Part No: 25G110R120

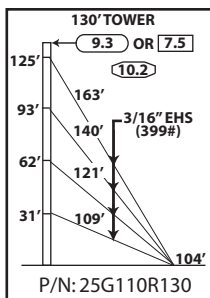

TOWER PARTS INCLUDED	25G	25AG2	BPC25G	GA25GD	FDNS	
					BASE	ANCHOR
	12	1	1	4	CB1G	AB2
GUYS & CONNECTIONS INCLUDED	3/16EHS	BG2142	5/16THH	1/2TBE&J	TBSAFETY	
	1700'	24	24	12	3	
ANCHORS & GROUNDING INCLUDED	GAC3455TOP	AGK1GGX	BGK3GGX	CPC.5/.75	3/4x12PP	
	3	1	3	3	1	

130' ROHN 25G
 All parts shown in table are included when ordering
 Part No: 25G110R130



STANDARD DESIGN - 25G
110MPH REV. G, 90MPH REV. F

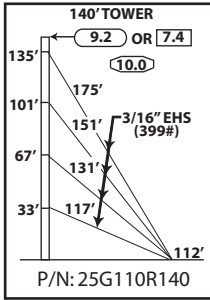

TOWER PARTS INCLUDED	25G	25AG2	BPC25G	GA25GD	FDNS	
					BASE	ANCHOR
	13	1	1	4	CB1G	AB2
GUYS & CONNECTIONS INCLUDED	3/16EHS	BG2142	5/16THH	1/2TBE&J	TBSAFETY	
	1825'	24	24	12	3	
ANCHORS & GROUNDING INCLUDED	GAC3455TOP	AGK1GGX	BGK3GGX	CPC.5/.75	3/4x12PP	
	3	1	3	3	1	

140' ROHN 25G
All parts shown in table are included when ordering
Part No: 25G110R140

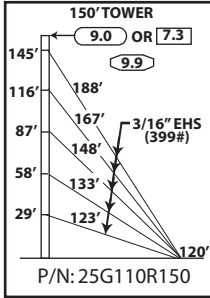

TOWER PARTS INCLUDED	25G	25AG2	BPC25G	GA25GD	FDNS	
					BASE	ANCHOR
	14	1	1	5	CB1G	AB2
GUYS & CONNECTIONS INCLUDED	3/16EHS	BG2142	5/16THH	1/2TBE&J	TBSAFETY	
	2425'	30	30	15	3	
ANCHORS & GROUNDING INCLUDED	GAC3455TOP	AGK1GGX	BGK3GGX	CPC.5/.75	3/4x12PP	
	3	1	3	3	1	

150' ROHN 25G
All parts shown in table are included when ordering
Part No: 25G110R150

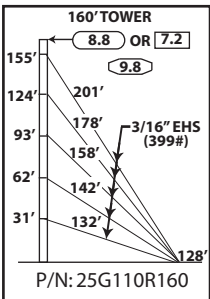

TOWER PARTS INCLUDED	25G	25AG2	BPC25G	GA25GD	FDNS	
					BASE	ANCHOR
	15	1	1	5	CB1G	AB2
GUYS & CONNECTIONS INCLUDED	3/16EHS	BG2142	5/16THH	1/2TBE&J	TBSAFETY	
	2600'	30	30	15	3	
ANCHORS & GROUNDING INCLUDED	GAC3455TOP	AGK1GGX	BGK3GGX	CPC.5/.75	3/4x12PP	
	3	1	3	3	1	

160' ROHN 25G
All parts shown in table are included when ordering
Part No: 25G110R160

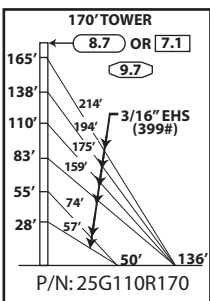

TOWER PARTS INCLUDED	25G	25AG2	BPC25G	GA25GD	BASE	INNER ANCHOR	OUTER ANCHOR
					CB2G	AB2	AB2
	16	1	1	6	CB2G	AB2	AB2
GUYS & CONNECTIONS INCLUDED	3/16EHS	BG2142	5/16THH	1/2TBE&J	TBSAFETY		
	2800'	36	36	18	6		
ANCHORS & GROUNDING INCLUDED	GAC3455TOP	AGK1GGX	BGK3GGX	CPC.5/.75	3/4x12PP		
	6	2	3	6	1		

170' ROHN 25G
All parts shown in table are included when ordering
Part No: 25G110R170

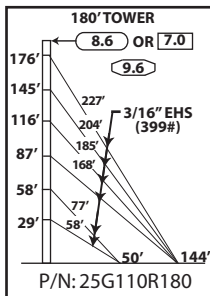

TOWER PARTS INCLUDED	25G	25AG2	BPC25G	GA25GD	BASE	INNER ANCHOR	OUTER ANCHOR
					CB2G	AB2	AB2
	17	1	1	6	CB2G	AB2	AB2
GUYS & CONNECTIONS INCLUDED	3/16EHS	BG2142	5/16THH	1/2TBE&J	TBSAFETY		
	2925'	36	36	18	6		
ANCHORS & GROUNDING INCLUDED	GAC3455TOP	AGK1GGX	BGK3GGX	CPC.5/.75	3/4x12PP		
	6	2	3	6	1		

180' ROHN 25G
All parts shown in table are included when ordering
Part No: 25G110R180



STANDARD DESIGN - 25G
110MPH REV. G, 90MPH REV. F

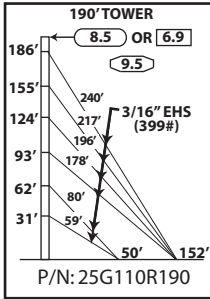

TOWER PARTS INCLUDED	25G	25AG2	BPC25G	GA25GD	BASE	INNER ANCHOR	OUTER ANCHOR
		18	1	1	6	CB2G	AB2
GUYS & CONNECTIONS INCLUDED	3/16EHS	BG2142	5/16THH	1/2TBE&J	TBSAFETY		
	3100'	36	36	18	6		
ANCHORS & GROUNDING INCLUDED	GAC3455TOP	AGK1GGX	BGK3GGX	CPC.5/.75	3/4x12PP		
	6	2	3	6	1		

190' ROHN 25G
All parts shown in table are included when ordering
Part No: 25G110R190



STANDARD DESIGN - 25G

130MPH REV. G, 110MPH REV. F

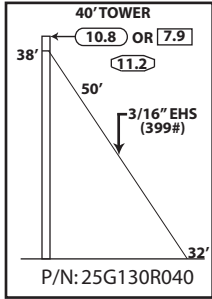

TOWER PARTS INCLUDED	25G	25AG2	BPC25G	GA25GD	FDNS	
					BASE	ANCHOR
TOWER PARTS INCLUDED	3	1	1	1	CB1G	AB2
GUYS & CONNECTIONS INCLUDED	3/16EHS	BG2142	5/16THH	1/2TBE&J	TBSAFETY	
	175'	6	6	3	3	
ANCHORS & GROUNDING INCLUDED	GAC3455TOP	AGK1GGX	BGK3GGX	CPC.5/.75	3/4x12PP	
	3	1	3	3	1	

40' ROHN 25G
All parts shown in table are included when ordering
Part No: 25G130R040

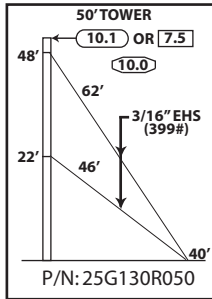

TOWER PARTS INCLUDED	25G	25AG2	BPC25G	GA25GD	FDNS	
					BASE	ANCHOR
TOWER PARTS INCLUDED	4	1	1	2	CB1G	AB2
GUYS & CONNECTIONS INCLUDED	3/16EHS	BG2142	5/16THH	1/2TBE&J	TBSAFETY	
	350'	12	12	6	3	
ANCHORS & GROUNDING INCLUDED	GAC3455TOP	AGK1GGX	BGK3GGX	CPC.5/.75	3/4x12PP	
	3	1	3	3	1	

50' ROHN 25G
All parts shown in table are included when ordering
Part No: 25G130R050

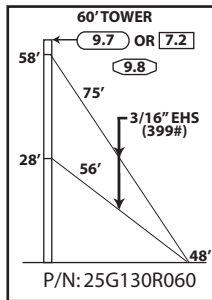

TOWER PARTS INCLUDED	25G	25AG2	BPC25G	GA25GD	FDNS	
					BASE	ANCHOR
TOWER PARTS INCLUDED	5	1	1	2	CB1G	AB2
GUYS & CONNECTIONS INCLUDED	3/16EHS	BG2142	5/16THH	1/2TBE&J	TBSAFETY	
	425'	12	12	6	3	
ANCHORS & GROUNDING INCLUDED	GAC3455TOP	AGK1GGX	BGK3GGX	CPC.5/.75	3/4x12PP	
	3	1	3	3	1	

60' ROHN 25G
All parts shown in table are included when ordering
Part No: 25G130R060

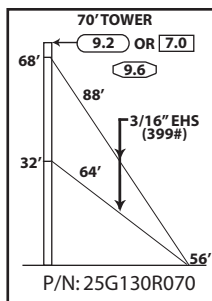

TOWER PARTS INCLUDED	25G	25AG2	BPC25G	GA25GD	FDNS	
					BASE	ANCHOR
TOWER PARTS INCLUDED	6	1	1	2	CB1G	AB2
GUYS & CONNECTIONS INCLUDED	3/16EHS	BG2142	5/16THH	1/2TBE&J	TBSAFETY	
	500'	12	12	6	3	
ANCHORS & GROUNDING INCLUDED	GAC3455TOP	AGK1GGX	BGK3GGX	CPC.5/.75	3/4x12PP	
	3	1	3	3	1	

70' ROHN 25G
All parts shown in table are included when ordering
Part No: 25G130R070

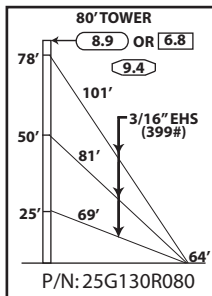

TOWER PARTS INCLUDED	25G	25AG2	BPC25G	GA25GD	FDNS	
					BASE	ANCHOR
TOWER PARTS INCLUDED	7	1	1	3	CB1G	AB2
GUYS & CONNECTIONS INCLUDED	3/16EHS	BG2142	5/16THH	1/2TBE&J	TBSAFETY	
	800'	18	18	9	3	
ANCHORS & GROUNDING INCLUDED	GAC3455TOP	AGK1GGX	BGK3GGX	CPC.5/.75	3/4x12PP	
	3	1	3	3	1	

80' ROHN 25G
All parts shown in table are included when ordering
Part No: 25G130R080



STANDARD DESIGN - 25G
130MPH REV. G, 110MPH REV. F

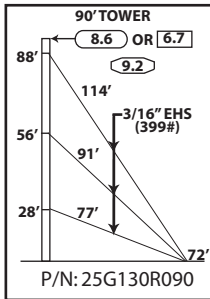

TOWER PARTS INCLUDED	25G	25AG2	BPC25G	GA25GD	FDNS	
					BASE	ANCHOR
	8	1	1	3	CB1G	AB2
GUYS & CONNECTIONS INCLUDED	3/16EHS	BG2142	5/16THH	1/2TBE&J	TBSAFETY	
	900'	18	18	9	3	
ANCHORS & GROUNDING INCLUDED	GAC3455TOP	AGK1GGX	BGK3GGX	CPC.5/.75	3/4x12PP	
	3	1	3	3	1	

90' ROHN 25G
 All parts shown in table are included when ordering
 Part No: 25G130R090

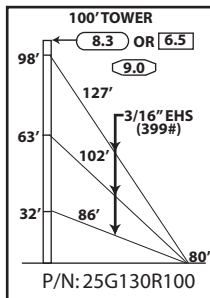

TOWER PARTS INCLUDED	25G	25AG2	BPC25G	GA25GD	FDNS	
					BASE	ANCHOR
	9	1	1	3	CB1G	AB2
GUYS & CONNECTIONS INCLUDED	3/16EHS	BG2142	5/16THH	1/2TBE&J	TBSAFETY	
	1000'	18	18	9	3	
ANCHORS & GROUNDING INCLUDED	GAC3455TOP	AGK1GGX	BGK3GGX	CPC.5/.75	3/4x12PP	
	3	1	3	3	1	

100' ROHN 25G
 All parts shown in table are included when ordering
 Part No: 25G130R100



PARTS & ACCESSORIES

<p>TOP SECTION 25AG COMES WITH TOP BUSHING INSTALLED, 1.31" I.D.</p>	<p>TOP SECTION 25AG1</p>	<p>TOP SECTION 25AG2</p>	<p>TOP SECTION 25AG3</p>
-----------------------------------------------------------------------------------------	-------------------------------------	-------------------------------------	-------------------------------------

<p>TOP SECTION 25AG4 TOP PLATE HOLE PATTERN IS THE SAME AS BPL25G.</p>	<p>TOP SECTION 25AG5</p>	<p>BEARING PLATE BPL25G LONG LEGS PROVIDE EXTRA CLEARANCE FOR INSTALLATION OF EQUIPMENT. BOLTS TO TOP OF STANDARD SECTION. HOLE PATTERN FITS TB3 (2" O.D.) AND TB4 (3" O.D.) THRUST BEARINGS.</p>	<p>TOP PLATE APL25G FOR MOUNTING BEACON OR LIGHTNING ROD.</p>
-------------------------------------------------------------------------------------------	-------------------------------------	----------------------------------------------------------------------------------------------------------------------------------------------------------------------------------------------------------------------------------	----------------------------------------------------------------------------------

<p>TOP MOUNT 25TDMKD - NO MAST 25TDM2S3KD - 2 3/8" O.D. MAST 25TDM2S53KD - 2 7/8" O.D. MAST 25TDM3S3KD - 3 1/2" O.D. MAST 25TDM3S53KD - 4" O.D. MAST MOUNTING TUBE PROVIDED IS 7" LONG.</p>	<p>BEARING/ACCESSORY SHELF BAS25G HOLE PATTERN FITS TB3 (2" O.D.) AND TB4 (3" O.D.) THRUST BEARINGS ON TOP PLATE. ACCESSORY SHELF DRILLED FOR MOUNTING MANY POPULAR ROTORS.</p>	<p>LIGHTNING ROD LRCL 5' COPPER CLAD, MOUNTS TO APL25G.</p>
----------------------------------------------------------------------------------------------------------------------------------------------------------------------------------------------------------------------------	------------------------------------------------------------------------------------------------------------------------------------------------------------------------------------------------------------	----------------------------------------------------------------------------



PARTS & ACCESSORIES

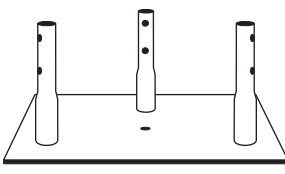

CONCRETE BASE PLATE
FOR GUYED & BRACKETED TOWERS
BPC25G*

FOR USE WITH 3/4X12PP PIER PIN
EMBEDDED IN CONCRETE.

CONCRETE BASE PLATE IS TO BE
USED FOR BRACKETED AND
GUYED APPLICATIONS ONLY.



PIER PIN
3/4X12PP

FOR USE WITH BPC25G
EMBEDDED IN CONCRETE.

PIER PIN MUST BE ORDERED
SEPARATELY, UNLESS BEING
PURCHASED AS PART OF
A COMPLETE TOWER KIT.

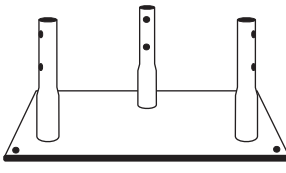

CONCRETE BASE PLATE
FOR SELF-SUPPORTING TOWERS
25GSSB

FOR USE WITH 5/8" x 12" (P/N: 260145G)
BASE BOLTS (ORDERED SEPARATELY)
IN SELF-SUPPORTING
25G TOWER APPLICATIONS.

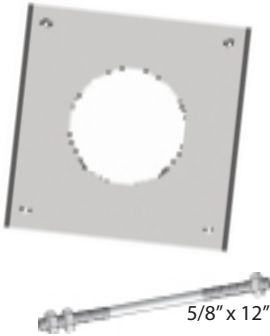

BASE BOLT & TEMPLATE
KH8175A

FOR USE WITH 25GSSB
IN SELF-SUPPORTING 25G TOWER
APPLICATIONS. KIT INCLUDES (1)
TEMPLATE & (4) BASE BOLTS.

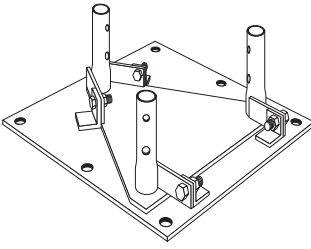

HINGED BASE PLATE
BPH25G*

FOR USE WITH 1/2X12BB BASE BOLTS
(ORDERED SEPARATELY).
HINGED TO ALLOW TOWER TO
BE ROTATED UP FROM BASE
DURING INSTALLATION.

HINGED BASE PLATE IS TO BE
USED FOR BRACKETED AND GUYED
APPLICATIONS ONLY.

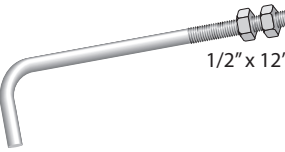

BASE BOLTS
1/2X12BB

FOR USE WITH BPH 25G
(6) REQUIRED, ORDERED SEPARATELY.

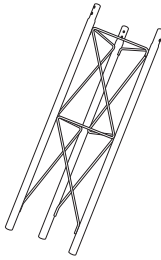

3'4" SHORT BASE
SB25G

5' SHORT BASE
SB25G5

FOR EMBEDMENT IN CONCRETE.

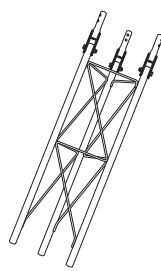

3'4" HINGED SHORT BASE
SBH25G*

FOR EMBEDMENT IN CONCRETE.



TAPERED BASE
25TG*

CAN BE USED WITH A4197L
BASE INSULATOR OR WITH 3/4x12PP,
ORDERED SEPARATELY.

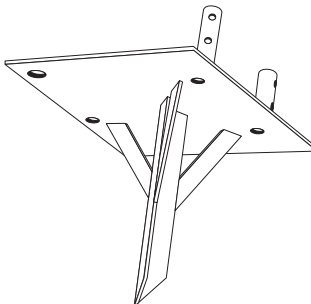

SINGLE DRIVE-IN BASE
SDB25G*

TO BE DRIVEN DIRECTLY INTO GROUND.

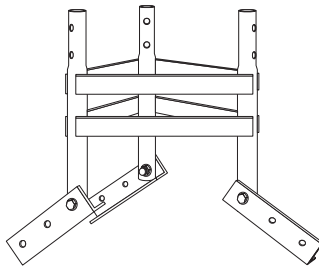

PEAK ROOF MOUNT
PR25G*

ADJUSTABLE HINGED FEET CONFORM
TO NEARLY ANY ROOF PITCH. BOLTS
TO ROOF SURFACE.

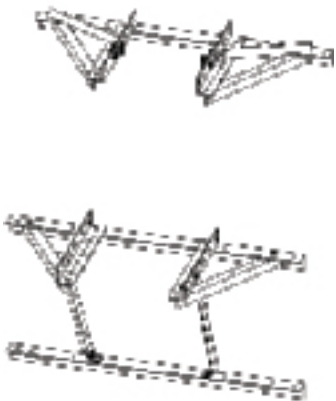

WALL MOUNT
25GWM

INCLUDES BASE PLATE TO
MOUNT 25G SECTION.

*TOWERS MOUNTED ON THESE BASES MUST BE BRACKETED OR GUYED AT ALL TIMES. TEMPORARY STEEL GUYING MAY ALSO BE NECESSARY DURING INSTALLATION AND DISMANTLING.

PARTS & ACCESSORIES

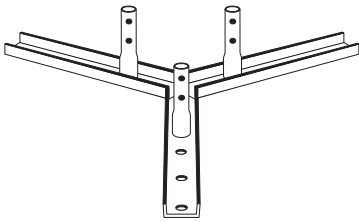

FLAT ROOF MOUNT
FR25G*

BOLTS DIRECTLY TO FLAT ROOF SURFACE.

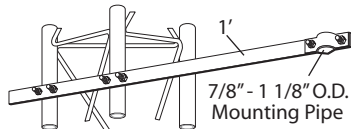

SIDE ARM MOUNT
UHF25G

FOR UHF & FM ANTENNAS.

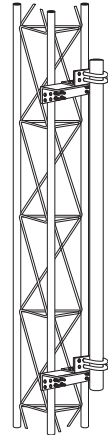

FACE MOUNT

DM25G2 - 2 3/8" O.D. 5' LONG

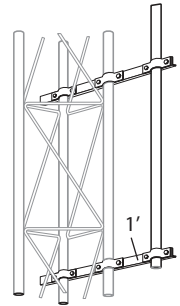

DBS ANTENNA MOUNT

KY2068A16 - 1.66" O.D.
KY2068A15 - 1.50" O.D.
KY2068A2 - 2.38" O.D.

MOUNTING TUBE PROVIDED IS 3' LONG.

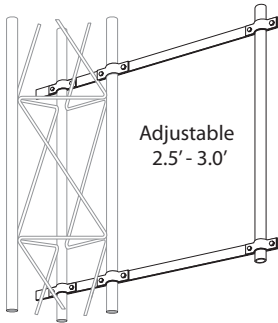

Adjustable
2.5' - 3.0'

SIDE ARM BRACKET
SA253UA

MOUNTING TUBE PROVIDED IS 3' LONG,
2 - 1/4" O.D.

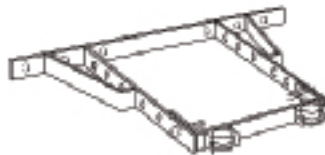

ADJUSTABLE HOUSE BRACKET

HB25AG 0 - 15"
HB25BG 0 - 24"
HB25CG 0 - 36"

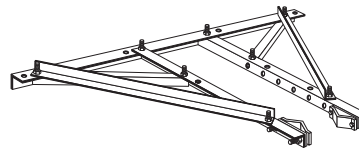

HEAVY DUTY UNIVERSAL HOUSE BRACKET
HBUTVRO

ADJUSTABLE TO POSITION TOWER
18" - 36" FROM WALL.

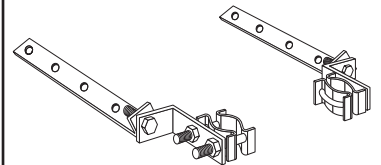

UNIVERSAL EAVE BRACKET
EB2525G

HINGED CONNECTION ALLOWS TOWER LEG CLAMPS TO REMAIN PERPENDICULAR TO GROUND WHILE BOLT DOWN SUPPORTS ROTATE TO LAY FLAT ALONG PITCHED ROOF OR EAVE.

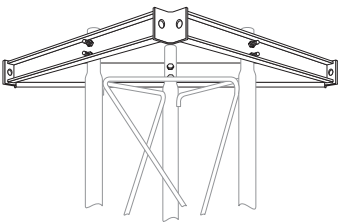

TORQUE ARM STABILIZER ASSEMBLY
TA25

ANTI-TWIST DEVICE LOCATED IN THE AREA OF ANTENNAS. PROVIDES SIX-WAY GUYING. BOLTS TO TOWER AT ANY SECTION JOINT. ATTACHED WITH JOINT BOLTS. MUST BE INSTALLED AS SECTIONS ARE JOINED TOGETHER.

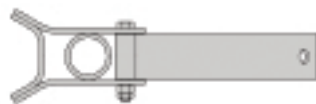

TORQUE BAR
TB25D

OPTIONAL, FOR USE WITH GA25GD.
REQUIRES (1) 3/8" SHACKLE FOR EACH BAR.

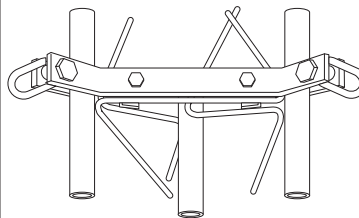

GUY BRACKET
GA25GD

MOUNTS TO TOWER AT ANY HORIZONTAL BRACE.

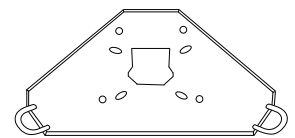

ACCESSORY SHELF
AS25G

FOR MOUNTING MANY POPULAR ROTORS. FIELD DRILLING MAY BE NECESSARY FOR SOME ROTORS.

* TOWERS MOUNTED ON THESE BASES MUST BE BRACKETED OR GUYED AT ALL TIMES. TEMPORARY STEEL GUYING MAY ALSO BE NECESSARY DURING INSTALLATION AND DISMANTLING.



PARTS & ACCESSORIES

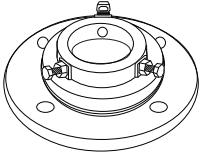

THRUST BEARING

TB3 - SUPPORTS UP TO 2" O.D. MAST.
TB4 - SUPPORTS UP TO 3" O.D. MAST.
MOUNTS TO BAS25G, BPL25G AND 25AG4.

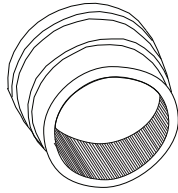

TOWER BUSHING

TB50 - 1-1/4" I.D. X 2" O.D.
FOR USE ON 25AG TOP SECTION

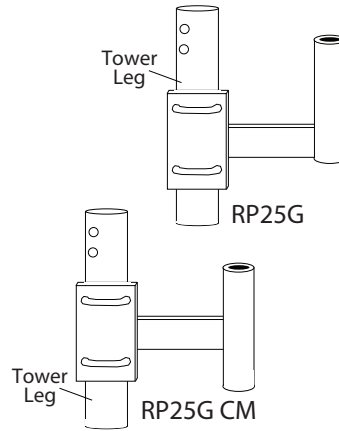

ROTOR POST

1.25" O.D.
1.08" I.D.



90° JOINTS

2590MM - BOTH ENDS SWAGED
JOINTS ARE NOT DRILLED WHERE THEY SLIP FIT TO 25G SECTIONS. CAN BE FIELD DRILLED OR CUSTOM CONNECTED TO MEET PARTICULAR NEEDS.

convenience



90° JOINTS

2590FF - BOTH ENDS OPEN
JOINTS ARE NOT DRILLED WHERE THEY SLIP FIT TO 25G SECTIONS. CAN BE FIELD DRILLED OR CUSTOM CONNECTED TO MEET PARTICULAR NEEDS.



90° JOINTS

2590FM - ONE END SWAGED, ONE OPEN
JOINTS ARE NOT DRILLED WHERE THEY SLIP FIT TO 25G SECTIONS. CAN BE FIELD DRILLED OR CUSTOM CONNECTED TO MEET PARTICULAR NEEDS.



ANTI-CLIMB PANELS
25ACL3

THREE ANTI-CLIMB PANELS BOLT TO STANDARD TOWER SECTION.

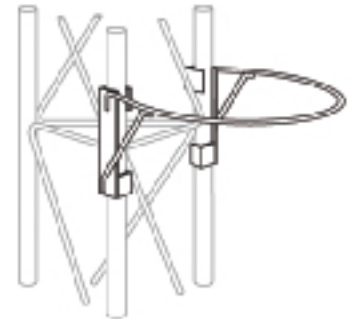

SAFETY RING
SR245

SNAPS INTO PLACE AT ANY LEVEL. NO BOLTS REQUIRED.



WORK PLATFORM
WP25G

SNAPS INTO PLACE AT ANY LEVEL. NO BOLTS REQUIRED.



ERECTION FIXTURE

EF2545 - 2 1/2" SHEAVE WITH 3/8" I.D. GROOVE.

NOTE: ERECTION FIXTURES ARE FOR LIFTING ONE 10' SECTION AT A TIME AND ARE NOT INTENDED FOR THE LIFTING OF PERSONNEL.

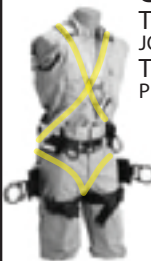

CLIMBING HARNESS

TTFBH-4D JOURNEYMAN HARNESS
TTFBH-C/P PROFESSIONAL HARNESS

SAFETY CABLE SLIDER WITH CARABINEER
TT-WG-500-W/SMC



SAFETY CABLE SYSTEM
ORDERING INFORMATION

Table with 2 columns: TOWER HEIGHT and PART NUMBER. Rows for 50', 100', 150', and 200' heights.

SAFETY CABLE SLIDER AND CLIMBING HARNESS MUST BE ORDERED SEPARATELY.

ANCHOR INFORMATION

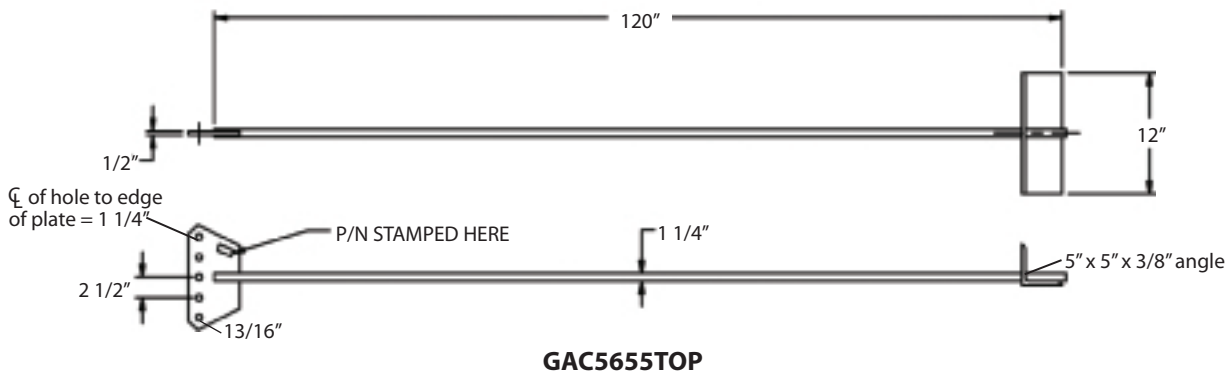
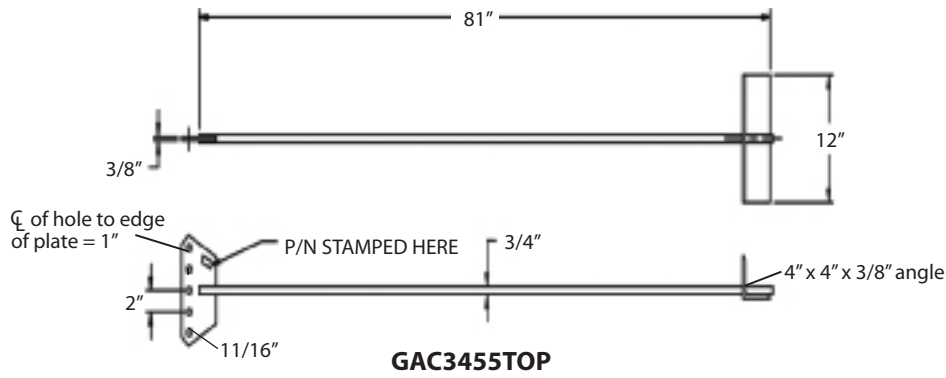

REV G
ANCHOR GROUNDING
AGK1GGX

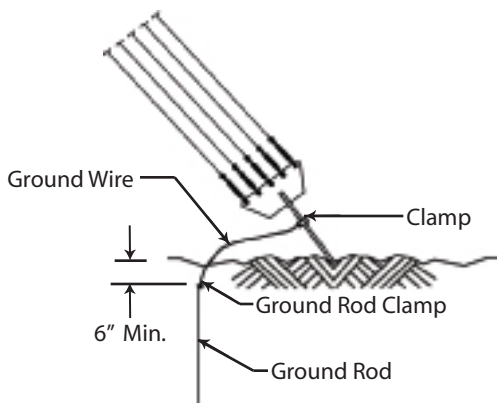

REV G
BASE GROUNDING
BGK3GGX

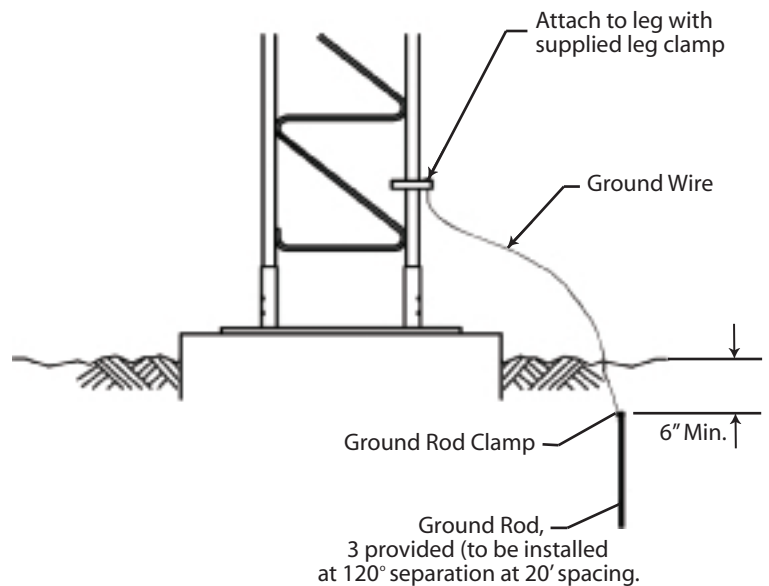

STANDARD ANCHOR BLOCKS

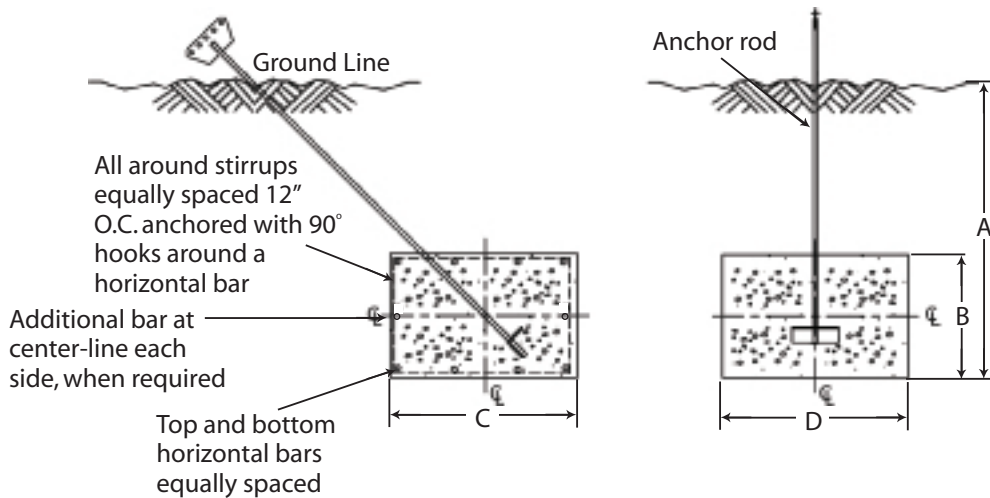

Refer to page 43 for anchor rod installation angles.

Block	Anchor Dimensions (in.)				Horizontal Bars (Qty. & Size)	Stirrup Size & Spacing	Concrete Vol. (Cu. Yds.)
	A	B	C	D			
AB2	4' - 0"	1' - 6"	4' - 0"	6' - 0"	(5) #6 Bars, Top Layer (5) #6 Bars, Bottom Layer (0) Additional Bar, Each Side	#3 @ 12" O.C.	1.33 Per Block 4.0 Total for 3
AB3	6' - 0"	1' - 6"	3' - 0"	6' - 0"	(4) #6 Bars, Top Layer (4) #6 Bars, Bottom Layer (0) Additional Bar, Each Side	#3 @ 12" O.C.	1.0 Per Block 3.0 Total for 3
AB4	6' - 0"	1' - 6"	4' - 0"	9' - 0"	(5) #6 Bars, Top Layer (5) #6 Bars, Bottom Layer (0) Additional Bar, Each Side	#4 @ 12" O.C.	2.0 Per Block 6.0 Total for 3
AB5	8' - 0"	2' - 0"	3' - 0"	10' - 0"	(4) #7 Bars, Top Layer (4) #7 Bars, Bottom Layer (1) Additional Bar, Each Side	#4 @ 12" O.C.	2.22 Per Block 6.7 Total for 3
AB6	8' - 0"	2' - 0"	4' - 0"	10' - 0"	(5) #7 Bars, Top Layer (5) #7 Bars, Bottom Layer (1) Additional Bar, Each Side	#4 @ 12" O.C.	2.96 Per Block 8.9 Total for 3

ANCHOR ROD INSTALLATION ANGLES

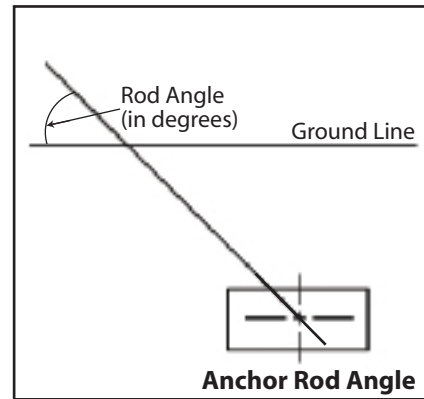
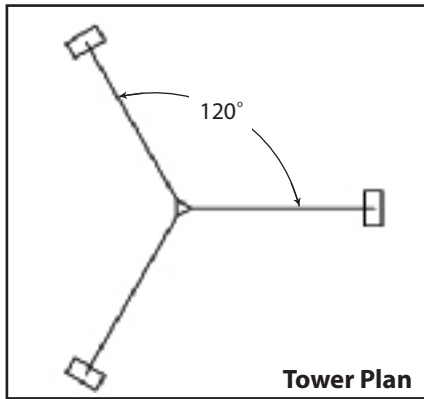

25G 90MPH		
Tower Height	Rod Number	Rod Angle
40'	GAC3455TOP	48
50'	GAC3455TOP	42
60'	GAC3455TOP	42
70'	GAC3455TOP	42
80'	GAC3455TOP	39
90'	GAC3455TOP	39
100'	GAC3455TOP	39
110'	GAC3455TOP	39
120'	GAC3455TOP	38
130'	GAC3455TOP	38
140'	GAC3455TOP	38
150'	GAC3455TOP	37
160'	GAC3455TOP	37
170'	GAC3455TOP	37
180'	GAC3455TOP	37
190'	GAC3455TOP	37

25G 110MPH				
Tower Height	Inner Rod Number	Inner Rod Angle	Outer Rod Number	Outer Rod Angle
40'	GAC3455TOP	48	-	-
50'	GAC3455TOP	41	-	-
60'	GAC3455TOP	41	-	-
70'	GAC3455TOP	41	-	-
80'	GAC3455TOP	38	-	-
90'	GAC3455TOP	38	-	-
100'	GAC3455TOP	39	-	-
110'	GAC3455TOP	38	-	-
120'	GAC3455TOP	37	-	-
130'	GAC3455TOP	37	-	-
140'	GAC3455TOP	37	-	-
150'	GAC3455TOP	36	-	-
160'	GAC3455TOP	36	-	-
170'	GAC3455TOP	40	GAC3455TOP	42
180'	GAC3455TOP	41	GAC3455TOP	42
190'	GAC3455TOP	43	GAC3455TOP	42

25G 130MPH		
Tower Height	Rod Number	Rod Angle
40'	GAC3455TOP	50
50'	GAC3455TOP	41
60'	GAC3455TOP	41
70'	GAC3455TOP	40
80'	GAC3455TOP	38
90'	GAC3455TOP	38
100'	GAC3455TOP	38

STANDARD BASE PIERS

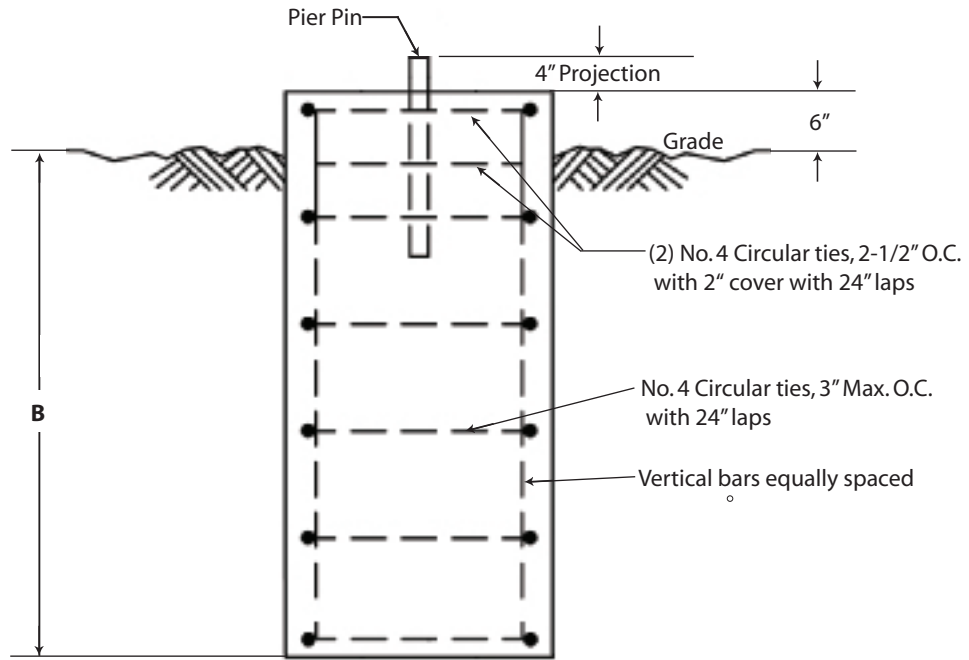

ELEVATION VIEW

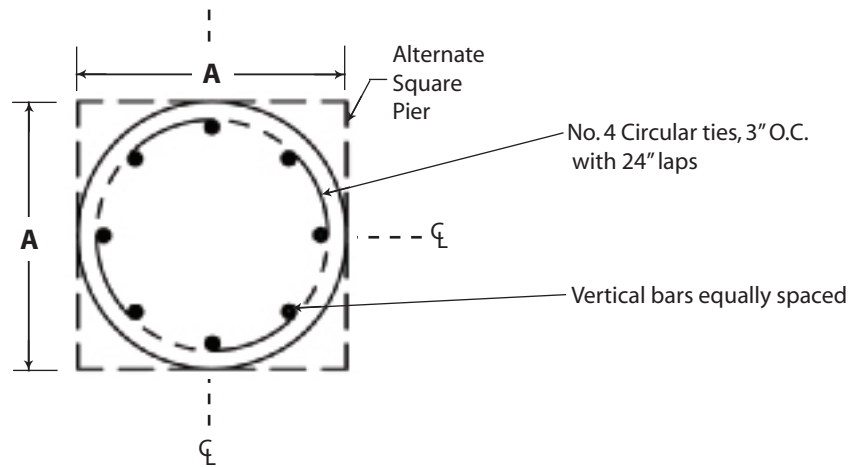

PLAN VIEW

Base	A	B	Concrete Vol. (Cu. Yds.) Round Pier	Vertical Bars (No. & Size)
CB1G*	2' - 6"	4' - 0"	1.0	(8) #7
CB2G	3' - 0"	4' - 0"	1.2	(10) #7

* Square pier option must be used for CB1G.

NOTES

Lined area for notes, featuring a background image of a lighting rig structure and a large stylized letter 'A'.



STANDARD 45G GUYED TOWER

ROHN 45G
The first. The original.



45G



GENERAL USE

The 45G is a true multi-use structure that provides excellent strength for applications up to 300'. It is offered with heavy steel round legs to satisfy a variety of needs under varied conditions.

FEATURES

- Completely hot-dip galvanized after fabrication
- Built on a 16 3/4" equilateral triangle design
- High strength tubular legs joined by Zig-Zag® cross members
- Each section contains all required nuts and bolts shipped with section
- Continuous solid round steel bracing

CAUTION

Mixing copies of ROHN towers with ROHN towers is dangerous and voids all engineering and warranty data supplied by ROHN. Materials used by others are not the same quality and have not been tested or engineered by ROHN. Mixing ROHN tower sections with non-ROHN products may cause tower failure or injury.

Per Rev G requirements, any structure greater than 10' requires a climber safety device. Please see page 65 for ordering information.



STANDARD 45G GUYED TOWER SECTIONS

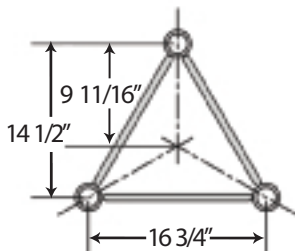

QUICK REFERENCE	
PARTS & ACCESSORIES	PAGES 63-65
GROUNDING INFORMATION	PAGE 66
FOUNDATION INFORMATION	PAGES 66-69

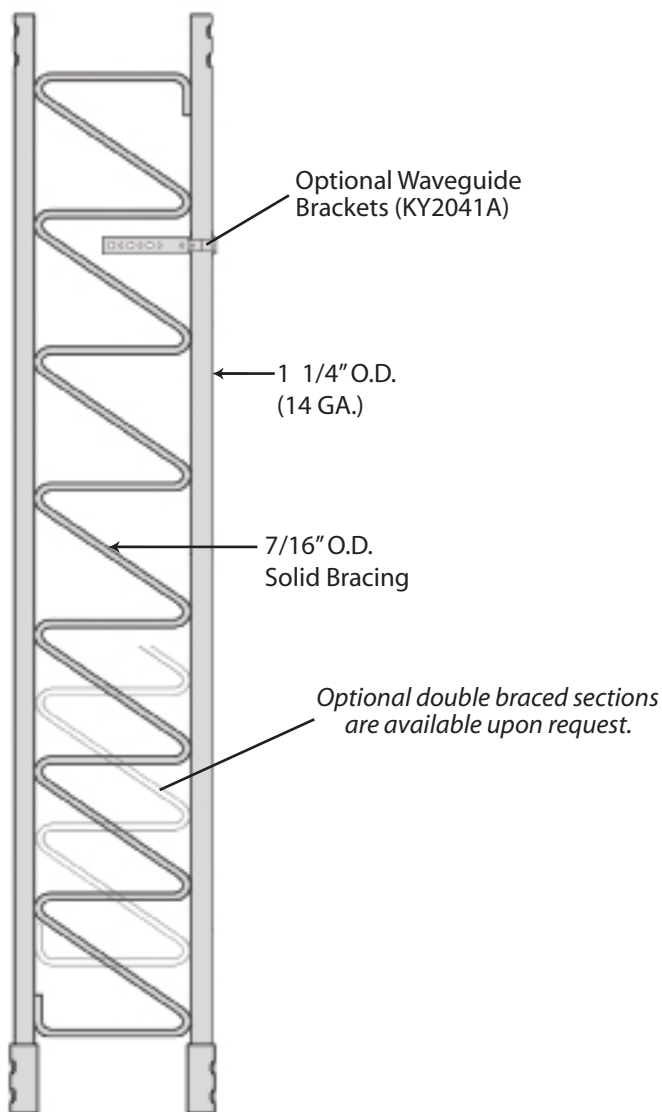

STANDARD SECTION 45G - 10' Section

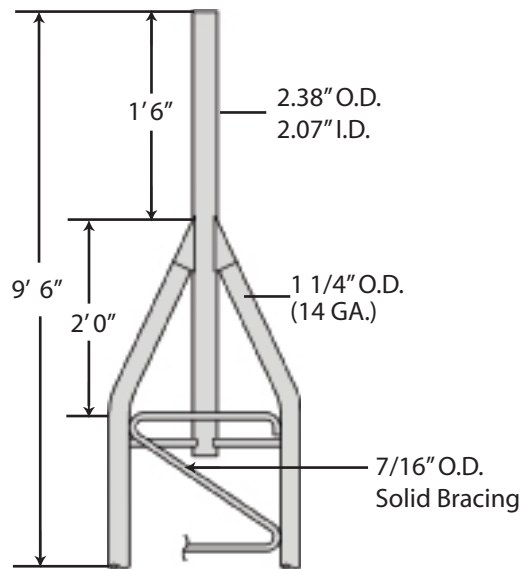

STANDARD TOP SECTION 45AG2

Additional 45G top sections are shown on page 63.

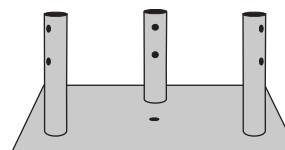

CONCRETE BASE PLATE BPC45G*

FOR USE WITH 3/4X12PP PIER PIN EMBEDDED IN CONCRETE.

Additional base sections are available, please see page 64.

* Towers mounted on these bases must be bracketed or guyed at all times. Temporary steel guying may also be necessary during installation and dismantling.



BUYERS GUIDE
STANDARD DESIGNS - 45G
90MPH REV. G [3-SECOND GUST]
70MPH REV. F [FASTEST MILE]

Design Criteria

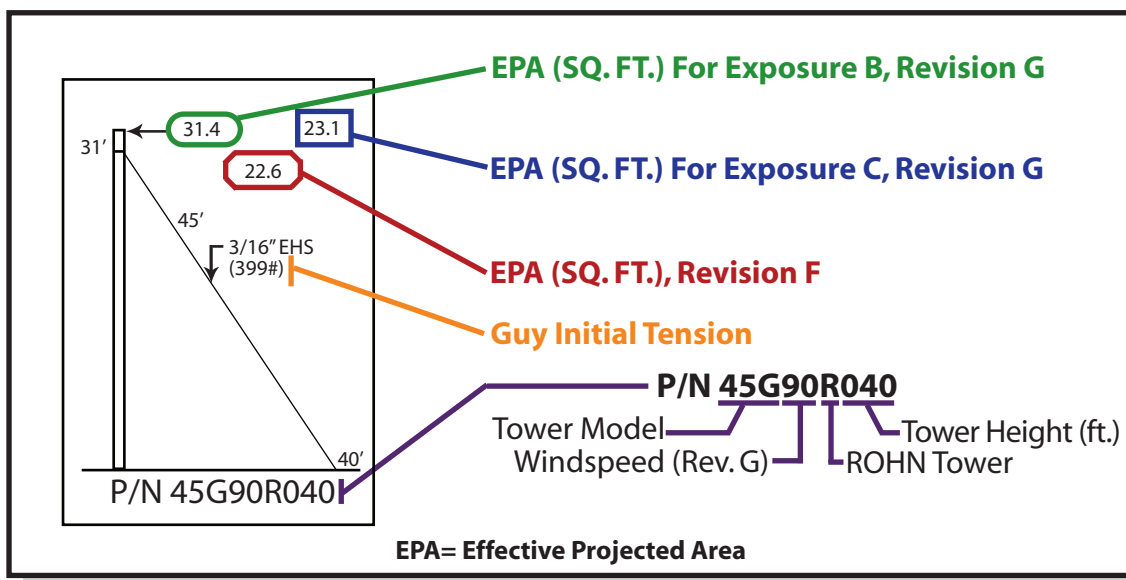

EPA= Effective Projected Area

This document is to serve as a guide for sizing and purchasing the 45G tower. Tower and foundation installations should be performed by qualified and experienced personnel using assembly drawings provided with each tower.

DESIGN NOTES:

- 1. Tower designs are in accordance with ANSI/TIA-222-F and ANSI/TIA-222-G, Class I Structures, Topographic Category 1.
2. Design assumes towers are installed on level ground. Lower EPA values will apply for roof mounted towers or for sites located on unusual terrain.
3. Designs assume two 1/2" diameter lines on each tower face.
4. Anchor radius is from tower base to intersection of anchor rod with ground.
5. Guy chord lengths shown are based on level ground. Initial tensions for guys are shown in () in pounds at 60° Fahrenheit.
6. Antenna and mounts are assumed symmetrically placed at the tower top.

PARTS LIST NOTES:

- 1. Items listed are required for complete guyed towers.
2. Base and anchor foundations listed refer to standard foundation designations.
3. Guys provided with each standard tower are based on level ground conditions with an additional 6% length.
4. Rev G anchor grounding (AGK1GGX) and base grounding (BGK3GGX) are included with the tower material.
5. Assembly drawings and a safety package (P/N: ACWS) are included with each tower.
6. Parts lists are subject to change based on availability or revised design criteria.

FOR FOUNDATION INFORMATION, PLEASE SEE PAGES 66-69.
FOR GENERAL INSTALLATION INFORMATION, PLEASE SEE PAGES 147-153.



STANDARD DESIGN - 45G 90MPH REV. G, 70MPH REV. F

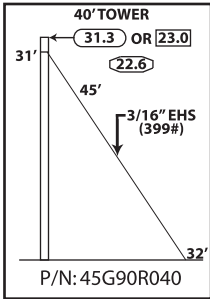

TOWER PARTS INCLUDED	45G	45AG2	BPC45G	GA45GD	FDNS	
					BASE	ANCHOR
	3	1	1	1	CB1G	AB2
GUYS & CONNECTIONS INCLUDED	3/16EHS	BG2142	5/16THH	1/2TBE&J	TBSAFETY	
	150'	6	6	3	3	
ANCHORS & GROUNDING INCLUDED	GAC3455TOP	AGK1GGX	BGK3GGX	CPC.5/.75	3/4x12PP	
	3	1	3	3	1	

40' ROHN 45G
All parts shown in table are included when ordering
Part No: 45G90R040

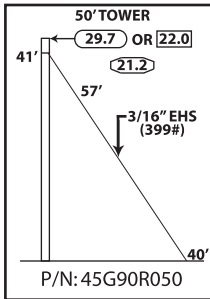

TOWER PARTS INCLUDED	45G	45AG2	BPC45G	GA45GD	FDNS	
					BASE	ANCHOR
	4	1	1	1	CB1G	AB2
GUYS & CONNECTIONS INCLUDED	3/16EHS	BG2142	5/16THH	1/2TBE&J	TBSAFETY	
	200'	6	6	3	3	
ANCHORS & GROUNDING INCLUDED	GAC3455TOP	AGK1GGX	BGK3GGX	CPC.5/.75	3/4x12PP	
	3	1	3	3	1	

50' ROHN 45G
All parts shown in table are included when ordering
Part No: 45G90R050

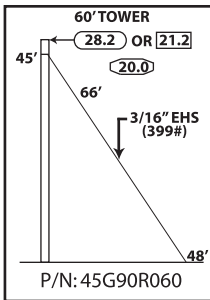

TOWER PARTS INCLUDED	45G	45AG2	BPC45G	GA45GD	FDNS	
					BASE	ANCHOR
	5	1	1	1	CB1G	AB2
GUYS & CONNECTIONS INCLUDED	3/16EHS	BG2142	5/16THH	1/2TBE&J	TBSAFETY	
	225'	6	6	3	3	
ANCHORS & GROUNDING INCLUDED	GAC3455TOP	AGK1GGX	BGK3GGX	CPC.5/.75	3/4x12PP	
	3	1	3	3	1	

60' ROHN 45G
All parts shown in table are included when ordering
Part No: 45G90R060

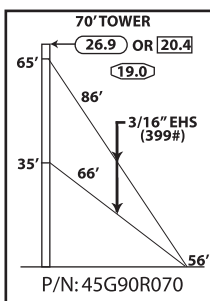

TOWER PARTS INCLUDED	45G	45AG2	BPC45G	GA45GD	FDNS	
					BASE	ANCHOR
	6	1	1	2	CB1G	AB2
GUYS & CONNECTIONS INCLUDED	3/16EHS	BG2142	5/16THH	1/2TBE&J	TBSAFETY	
	500'	12	12	6	3	
ANCHORS & GROUNDING INCLUDED	GAC3455TOP	AGK1GGX	BGK3GGX	CPC.5/.75	3/4x12PP	
	3	1	3	3	1	

70' ROHN 45G
All parts shown in table are included when ordering
Part No: 45G90R070

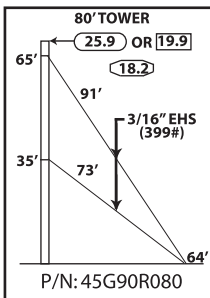

TOWER PARTS INCLUDED	45G	45AG2	BPC45G	GA45GD	FDNS	
					BASE	ANCHOR
	7	1	1	2	CB1G	AB2
GUYS & CONNECTIONS INCLUDED	3/16EHS	BG2142	5/16THH	1/2TBE&J	TBSAFETY	
	525'	12	12	6	3	
ANCHORS & GROUNDING INCLUDED	GAC3455TOP	AGK1GGX	BGK3GGX	CPC.5/.75	3/4x12PP	
	3	1	3	3	1	

80' ROHN 45G
All parts shown in table are included when ordering
Part No: 45G90R080



STANDARD DESIGN - 45G
90MPH REV. G, 70MPH REV. F

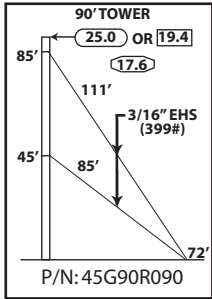

TOWER PARTS INCLUDED	45G	45AG2	BPC45G	GA45GD	FDNS	
					BASE	ANCHOR
TOWER PARTS INCLUDED	8	1	1	2	CB1G	AB2
GUYS & CONNECTIONS INCLUDED	3/16EHS	BG2142	5/16THH	1/2TBE&J	TBSAFETY	
	625'	12	12	6	3	
ANCHORS & GROUNDING INCLUDED	GAC3455TOP	AGK1GGX	BGK3GGX	CPC.5/.75	3/4x12PP	
	3	1	3	3	1	

90' ROHN 45G
All parts shown in table are included when ordering
Part No: 45G90R090

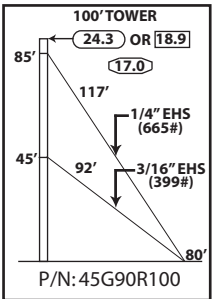

TOWER PARTS INCLUDED	45G	45AG2	BPC45G	GA45GD	FDNS		
					BASE	ANCHOR	
TOWER PARTS INCLUDED	9	1	1	2	CB1G	AB2	
GUYS & CONNECTIONS INCLUDED	3/16EHS	1/4EHS	BG2142	BG2144	5/16THH	3/8THH	1/2TBE&J
	300'	375'	6	6	6	6	6
ANCHORS & GROUNDING INCLUDED	GAC3455TOP	AGK1GGX	BGK3GGX	CPC.5/.75	3/4x12PP	TBSAFETY	
	3	1	3	3	1	3	

100' ROHN 45G
All parts shown in table are included when ordering
Part No: 45G90R100

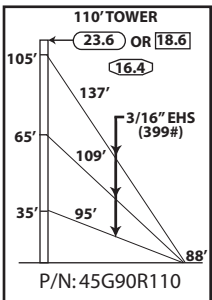

TOWER PARTS INCLUDED	45G	45AG2	BPC45G	GA45GD	FDNS	
					BASE	ANCHOR
TOWER PARTS INCLUDED	10	1	1	3	CB1G	AB2
GUYS & CONNECTIONS INCLUDED	3/16EHS	BG2142	5/16THH	1/2TBE&J	TBSAFETY	
	1100'	18	18	9	3	
ANCHORS & GROUNDING INCLUDED	GAC3455TOP	AGK1GGX	BGK3GGX	CPC.5/.75	3/4x12PP	
	3	1	3	3	1	

110' ROHN 45G
All parts shown in table are included when ordering
Part No: 45G90R110

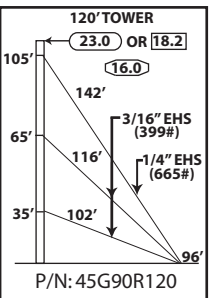

TOWER PARTS INCLUDED	45G	45AG2	BPC45G	GA45GD	FDNS		
					BASE	ANCHOR	
TOWER PARTS INCLUDED	11	1	1	3	CB1G	AB2	
GUYS & CONNECTIONS INCLUDED	3/16EHS	1/4EHS	BG2142	BG2144	5/16THH	3/8THH	1/2TBE&J
	700'	475'	12	6	12	6	9
ANCHORS & GROUNDING INCLUDED	GAC3455TOP	AGK1GGX	BGK3GGX	CPC.5/.75	3/4x12PP	TBSAFETY	
	3	1	3	3	1	3	

120' ROHN 45G
All parts shown in table are included when ordering
Part No: 45G90R120

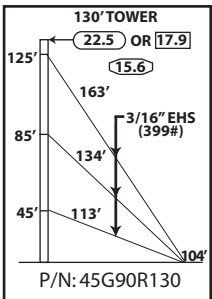

TOWER PARTS INCLUDED	45G	45AG2	BPC45G	GA45GD	FDNS	
					BASE	ANCHOR
TOWER PARTS INCLUDED	12	1	1	3	CB1G	AB2
GUYS & CONNECTIONS INCLUDED	3/16EHS	BG2142	5/16THH	1/2TBE&J	TBSAFETY	
	1325'	18	18	9	3	
ANCHORS & GROUNDING INCLUDED	GAC3455TOP	AGK1GGX	BGK3GGX	CPC.5/.75	3/4x12PP	
	3	1	3	3	1	

130' ROHN 45G
All parts shown in table are included when ordering
Part No: 45G90R130



STANDARD DESIGN - 45G 90MPH REV. G, 70MPH REV. F

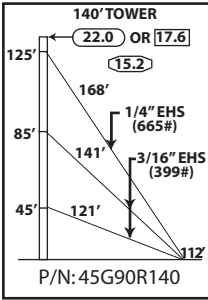

TOWER PARTS INCLUDED	45G	45AG2	BPC45G	GA45GD	FDNS		
	13	1	1	3	BASE	ANCHOR	
GUYS & CONNECTIONS INCLUDED	3/16EHS	1/4EHS	BG2142	BG2144	5/16THH	3/8THH	1/2TBE&J
	850'	550'	12	6	12	6	9
ANCHORS & GROUNDING INCLUDED	GAC3455TOP	AGK1GGX	BGK3GGX	CPC.5/.75	3/4x12PP	TBSAFETY	
	3	1	3	3	1	3	

140' ROHN 45G
All parts shown in table are included when ordering
Part No: 45G90R140

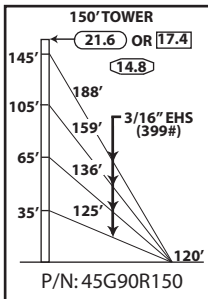

TOWER PARTS INCLUDED	45G	45AG2	BPC45G	GA45GD	FDNS	
	14	1	1	4	BASE	ANCHOR
GUYS & CONNECTIONS INCLUDED	3/16EHS	BG2142	5/16THH	1/2TBE&J	TBSAFETY	
	1950'	24	24	12	3	
ANCHORS & GROUNDING INCLUDED	GAC3455TOP	AGK1GGX	BGK3GGX	CPC.5/.75	3/4x12PP	
	3	1	3	3	1	

150' ROHN 45G
All parts shown in table are included when ordering
Part No: 45G90R150

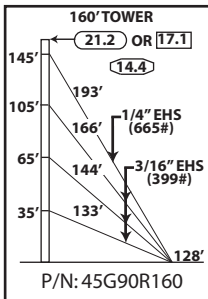

TOWER PARTS INCLUDED	45G	45AG2	BPC45G	GA45GD	FDNS		
	15	1	1	4	BASE	ANCHOR	
GUYS & CONNECTIONS INCLUDED	3/16EHS	1/4EHS	BG2142	BG2144	5/16THH	3/8THH	1/2TBE&J
	1425'	625'	18	6	18	6	12
ANCHORS & GROUNDING INCLUDED	GAC3455TOP	AGK1GGX	BGK3GGX	CPC.5/.75	3/4x12PP	TBSAFETY	
	3	1	3	3	1	3	

160' ROHN 45G
All parts shown in table are included when ordering
Part No: 45G90R160

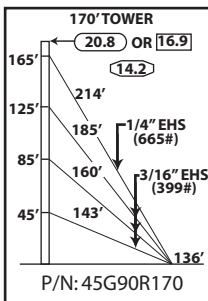

TOWER PARTS INCLUDED	45G	45AG2	BPC45G	GA45GD	FDNS		
	16	1	1	4	BASE	ANCHOR	
GUYS & CONNECTIONS INCLUDED	3/16EHS	1/4EHS	BG2142	BG2144	5/16THH	3/8THH	1/2TBE&J
	1575'	700'	18	6	18	6	12
ANCHORS & GROUNDING INCLUDED	GAC3455TOP	AGK1GGX	BGK3GGX	CPC.5/.75	3/4x12PP	TBSAFETY	
	3	1	3	3	1	3	

170' ROHN 45G
All parts shown in table are included when ordering
Part No: 45G90R170

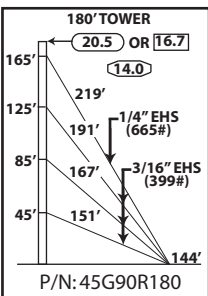

TOWER PARTS INCLUDED	45G	45AG2	BPC45G	GA45GD	FDNS		
	17	1	1	4	BASE	ANCHOR	
GUYS & CONNECTIONS INCLUDED	3/16EHS	1/4EHS	BG2142	BG2144	5/16THH	3/8THH	1/2TBE&J
	1625'	700'	18	6	18	6	12
ANCHORS & GROUNDING INCLUDED	GAC3455TOP	AGK1GGX	BGK3GGX	CPC.5/.75	3/4x12PP	TBSAFETY	
	3	1	3	3	1	3	

180' ROHN 45G
All parts shown in table are included when ordering
Part No: 45G90R180



STANDARD DESIGN - 45G
90MPH REV. G, 70MPH REV. F

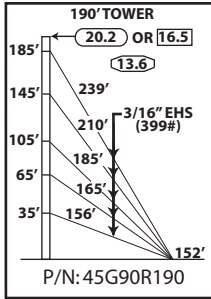

TOWER PARTS INCLUDED	45G	45AG2	BPC45G	GA45GD	FDNS	
					BASE	ANCHOR
	18	1	1	5	CB1G	AB2
GUYS & CONNECTIONS INCLUDED	3/16EHS	BG2142	5/16THH	1/2TBE&J	TBSAFETY	
	3050'	30	30	15	3	
ANCHORS & GROUNDING INCLUDED	GAC3455TOP	AGK1GGX	BGK3GGX	CPC.5/.75	3/4x12PP	
	3	1	3	3	1	

190' ROHN 45G
All parts shown in table are included when ordering
Part No: 45G90R190

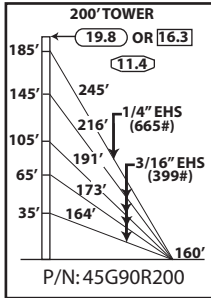

TOWER PARTS INCLUDED	45G	BPC45G	APL45G	GA45GD	FDNS		
					BASE	ANCHOR	
	20	1	1	5	CB1G	AB2	
GUYS & CONNECTIONS INCLUDED	3/16EHS	1/4EHS	BG2142	BG2144	5/16THH	3/8THH	1/2TBE&J
	2375'	800'	24	6	24	6	15
ANCHORS & GROUNDING INCLUDED	GAC3455TOP	AGK1GGX	BGK3GGX	CPC.5/.75	3/4x12PP	TBSAFETY	
	3	1	3	3	1	3	

200' ROHN 45G
All parts shown in table are included when ordering
Part No: 45G90R200

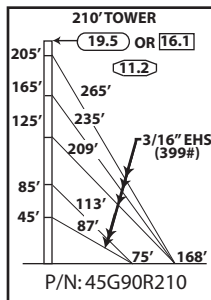

TOWER PARTS INCLUDED	45G	APL45G	BPC45G	GA45GD	BASE	INNER ANCHOR	OUTER ANCHOR
					21	1	1
GUYS & CONNECTIONS INCLUDED	3/16EHS	BG2142	5/16THH	1/2TBE&J	TBSAFETY		
	2900'	30	30	15	6		
ANCHORS & GROUNDING INCLUDED	GAC3455TOP	AGK1GGX	BGK3GGX	CPC.5/.75	3/4x12PP		
	6	2	3	6	1		

210' ROHN 45G
All parts shown in table are included when ordering
Part No: 45G90R210

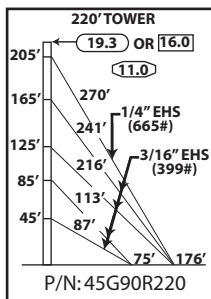

TOWER PARTS INCLUDED	45G	BPC45G	APL45G	GA45GD	BASE	INNER ANCHOR	OUTER ANCHOR
					22	1	1
GUYS & CONNECTIONS INCLUDED	3/16EHS	1/4EHS	BG2142	BG2144	5/16THH	3/8THH	1/2TBE&J
	2100'	875'	24	6	24	6	15
ANCHORS & GROUNDING INCLUDED	GAC3455TOP	AGK1GGX	BGK3GGX	CPC.5/.75	3/4x12PP	TBSAFETY	
	6	2	3	6	1	6	

220' ROHN 45G
All parts shown in table are included when ordering
Part No: 45G90R220

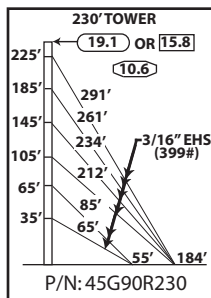

TOWER PARTS INCLUDED	45G	APL45G	BPC45G	GA45GD	BASE	INNER ANCHOR	OUTER ANCHOR
					23	1	1
GUYS & CONNECTIONS INCLUDED	3/16EHS	BG2142	5/16THH	1/2TBE&J	TBSAFETY		
	3675'	36	36	18	6		
ANCHORS & GROUNDING INCLUDED	GAC3455TOP	AGK1GGX	BGK3GGX	CPC.5/.75	3/4x12PP		
	6	2	3	6	1		

230' ROHN 45G
All parts shown in table are included when ordering
Part No: 45G90R230



STANDARD DESIGN - 45G 90MPH REV. G, 70MPH REV. F

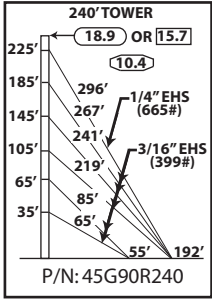

TOWER PARTS INCLUDED	45G	BPC45G	APL45G	GA45GD	BASE	INNER ANCHOR	OUTER ANCHOR
	24	1	1	6	CB2G	AB1	AB2
GUYS & CONNECTIONS INCLUDED	3/16EHS	1/4EHS	BG2142	BG2144	5/16THH	3/8THH	1/2TBE&J
	2800'	950'	30	6	30	6	18
ANCHORS & GROUNDING INCLUDED	GAC3455TOP	AGK1GGX	BGK3GGX	CPC.5/.75	3/4x12PP	TBSAFETY	
	6	2	3	6	1	6	

240' ROHN 45G
All parts shown in table are included when ordering
Part No: 45G90R240

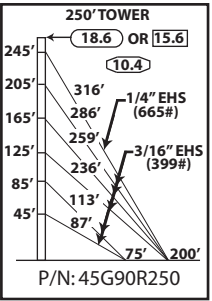

TOWER PARTS INCLUDED	45G	BPC45G	APL45G	GA45GD	BASE	INNER ANCHOR	OUTER ANCHOR
	25	1	1	6	CB2G	AB1	AB2
GUYS & CONNECTIONS INCLUDED	3/16EHS	1/4EHS	BG2142	BG2144	5/16THH	3/8THH	1/2TBE&J
	3125'	1025'	30	6	30	6	18
ANCHORS & GROUNDING INCLUDED	GAC3455TOP	AGK1GGX	BGK3GGX	CPC.5/.75	3/4x12PP	TBSAFETY	
	6	2	3	6	1	6	

250' ROHN 45G
All parts shown in table are included when ordering
Part No: 45G90R250

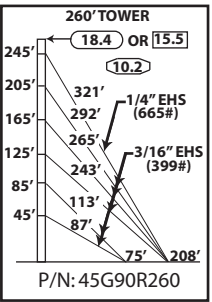

TOWER PARTS INCLUDED	45G	BPC45G	APL45G	GA45GD	BASE	INNER ANCHOR	OUTER ANCHOR
	26	1	1	6	CB3G	AB2	AB2
GUYS & CONNECTIONS INCLUDED	3/16EHS	1/4EHS	BG2142	BG2144	5/16THH	3/8THH	1/2TBE&J
	3200'	1025'	30	6	30	6	18
ANCHORS & GROUNDING INCLUDED	GAC3455TOP	AGK1GGX	BGK3GGX	CPC.5/.75	3/4x12PP	TBSAFETY	
	6	2	3	6	1	6	

260' ROHN 45G
All parts shown in table are included when ordering
Part No: 45G90R260

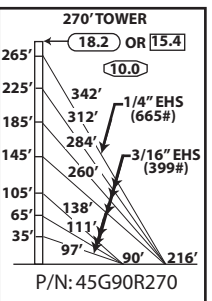

TOWER PARTS INCLUDED	45G	BPC45G	APL45G	GA45GD	BASE	INNER ANCHOR	OUTER ANCHOR
	27	1	1	7	CB3G	AB2	AB2
GUYS & CONNECTIONS INCLUDED	3/16EHS	1/4EHS	BG2142	BG2144	5/16THH	3/8THH	1/2TBE&J
	3825'	1100'	36	6	36	6	21
ANCHORS & GROUNDING INCLUDED	GAC3455TOP	AGK1GGX	BGK3GGX	CPC.5/.75	3/4x12PP	TBSAFETY	
	6	2	3	6	1	6	

270' ROHN 45G
All parts shown in table are included when ordering
Part No: 45G90R270

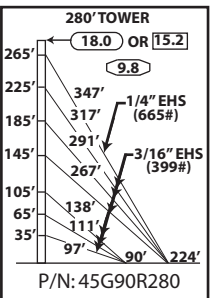

TOWER PARTS INCLUDED	45G	BPC45G	APL45G	GA45GD	BASE	INNER ANCHOR	OUTER ANCHOR
	28	1	1	7	CB3G	AB2	AB2
GUYS & CONNECTIONS INCLUDED	3/16EHS	1/4EHS	BG2142	BG2144	5/16THH	3/8THH	1/2TBE&J
	3900'	1125'	36	6	36	6	21
ANCHORS & GROUNDING INCLUDED	GAC3455TOP	AGK1GGX	BGK3GGX	CPC.5/.75	3/4x12PP	TBSAFETY	
	6	2	3	6	1	6	

280' ROHN 45G
All parts shown in table are included when ordering
Part No: 45G90R280



STANDARD DESIGN - 45G
90MPH REV. G, 70MPH REV. F

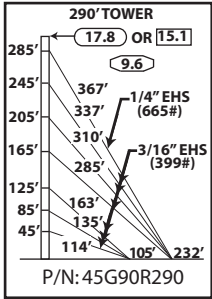

TOWER PARTS INCLUDED	45G	BPC45G	APL45G	GA45GD	BASE	INNER ANCHOR	OUTER ANCHOR
		29	1	1	7	CB3G	AB2
GUYS & CONNECTIONS INCLUDED	3/16EHS	1/4EHS	BG2142	BG2144	5/16THH	3/8THH	1/2TBE&J
	4275'	1175'	36	6	36	6	21
ANCHORS & GROUNDING INCLUDED	GAC3455TOP	AGK1GGX	BGK3GGX	CPC.5/.75	3/4x12PP	TBSAFETY	
	6	2	3	6	1	6	

290' ROHN 45G
All parts shown in table are included when ordering Part No: 45G90R290

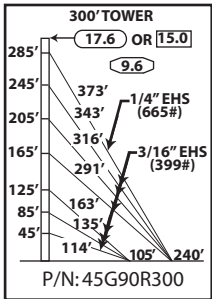

TOWER PARTS INCLUDED	45G	BPC45G	APL45G	GA45GD	BASE	INNER ANCHOR	OUTER ANCHOR
		30	1	1	7	CB3G	AB2
GUYS & CONNECTIONS INCLUDED	3/16EHS	1/4EHS	BG2142	BG2144	5/16THH	3/8THH	1/2TBE&J
	4350'	1200'	36	6	36	6	21
ANCHORS & GROUNDING INCLUDED	GAC3455TOP	AGK1GGX	BGK3GGX	CPC.5/.75	3/4x12PP	TBSAFETY	
	6	2	3	6	1	6	

300' ROHN 45G
All parts shown in table are included when ordering Part No: 45G90R300



STANDARD DESIGN - 45G
110MPH REV. G, 90MPH REV. F

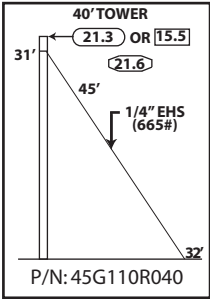

TOWER PARTS INCLUDED	45G	45AG2	BPC45G	GA45GD	FDNS	
	3	1	1	1	BASE CB1G	ANCHOR AB2
GUYS & CONNECTIONS INCLUDED	1/4EHS	BG2144	3/8THH	1/2TBE&J	TBSAFETY	
	150'	6	6	3	3	
ANCHORS & GROUNDING INCLUDED	GAC3455TOP	AGK1GGX	BGK3GGX	CPC.5/.75	3/4x12PP	
	3	1	3	3	1	

40' ROHN 45G
All parts shown in table are included when ordering
Part No: 45G110R040

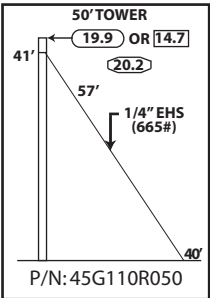

TOWER PARTS INCLUDED	45G	45AG2	BPC45G	GA45GD	FDNS	
	4	1	1	1	BASE CB1G	ANCHOR AB2
GUYS & CONNECTIONS INCLUDED	1/4EHS	BG2144	3/8THH	1/2TBE&J	TBSAFETY	
	200'	6	6	3	3	
ANCHORS & GROUNDING INCLUDED	GAC3455TOP	AGK1GGX	BGK3GGX	CPC.5/.75	3/4x12PP	
	3	1	3	3	1	

50' ROHN 45G
All parts shown in table are included when ordering
Part No: 45G110R050

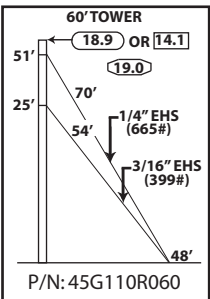

TOWER PARTS INCLUDED	45G	45AG2	BPC45G	GA45GD	FDNS		
	5	1	1	2	BASE CB1G	ANCHOR AB2	
GUYS & CONNECTIONS INCLUDED	3/16EHS	1/4EHS	BG2142	BG2144	5/16THH	3/8THH	1/2TBE&J
	175'	225'	6	6	6	6	6
ANCHORS & GROUNDING INCLUDED	GAC3455TOP	AGK1GGX	BGK3GGX	CPC.5/.75	3/4x12PP	TBSAFETY	
	3	1	3	3	1	3	

60' ROHN 45G
All parts shown in table are included when ordering
Part No: 45G110R060

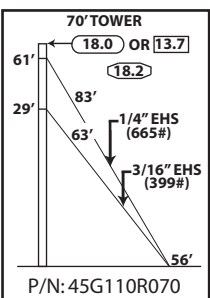

TOWER PARTS INCLUDED	45G	45AG2	BPC45G	GA45GD	FDNS		
	6	1	1	2	BASE CB1G	ANCHOR AB2	
GUYS & CONNECTIONS INCLUDED	3/16EHS	1/4EHS	BG2142	BG2144	5/16THH	3/8THH	1/2TBE&J
	225'	275'	6	6	6	6	6
ANCHORS & GROUNDING INCLUDED	GAC3455TOP	AGK1GGX	BGK3GGX	CPC.5/.75	3/4x12PP	TBSAFETY	
	3	1	3	3	1	3	

70' ROHN 45G
All parts shown in table are included when ordering
Part No: 45G110R070

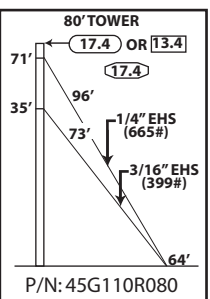

TOWER PARTS INCLUDED	45G	45AG2	BPC45G	GA45GD	FDNS		
	7	1	1	2	BASE CB1G	ANCHOR AB2	
GUYS & CONNECTIONS INCLUDED	3/16EHS	1/4EHS	BG2142	BG2144	5/16THH	3/8THH	1/2TBE&J
	250'	325'	6	6	6	6	6
ANCHORS & GROUNDING INCLUDED	GAC3455TOP	AGK1GGX	BGK3GGX	CPC.5/.75	3/4x12PP	TBSAFETY	
	3	1	3	3	1	3	

80' ROHN 45G
All parts shown in table are included when ordering
Part No: 45G110R080



STANDARD DESIGN - 45G
110MPH REV. G, 90MPH REV. F

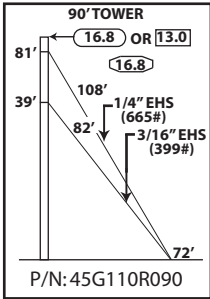

TOWER PARTS INCLUDED	45G	45AG2	BPC45G	GA45GD	FDNS		
	8	1	1	2	BASE	ANCHOR	
GUYS & CONNECTIONS INCLUDED	3/16EHS	1/4EHS	BG2142	BG2144	5/16THH	3/8THH	1/2TBE&J
	275'	350'	6	6	6	6	6
ANCHORS & GROUNDING INCLUDED	GAC3455TOP	AGK1GGX	BGK3GGX	CPC.5/.75	3/4x12PP	TBSAFETY	
	3	1	3	3	1	3	

90' ROHN 45G
 All parts shown in table are included when ordering
 Part No: 45G110R090

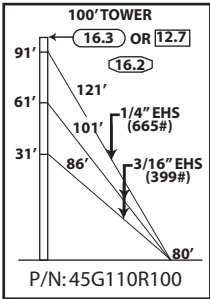

TOWER PARTS INCLUDED	45G	45AG2	BPC45G	GA45GD	FDNS		
	9	1	1	3	BASE	ANCHOR	
GUYS & CONNECTIONS INCLUDED	3/16EHS	1/4EHS	BG2142	BG2144	5/16THH	3/8THH	1/2TBE&J
	600'	400'	12	6	12	6	9
ANCHORS & GROUNDING INCLUDED	GAC3455TOP	AGK1GGX	BGK3GGX	CPC.5/.75	3/4x12PP	TBSAFETY	
	3	1	3	3	1	3	

100' ROHN 45G
 All parts shown in table are included when ordering
 Part No: 45G110R100

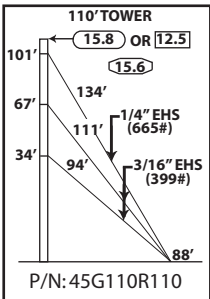

TOWER PARTS INCLUDED	45G	45AG2	BPC45G	GA45GD	FDNS		
	10	1	1	3	BASE	ANCHOR	
GUYS & CONNECTIONS INCLUDED	3/16EHS	1/4EHS	BG2142	BG2144	5/16THH	3/8THH	1/2TBE&J
	675'	450'	12	6	12	6	9
ANCHORS & GROUNDING INCLUDED	GAC3455TOP	AGK1GGX	BGK3GGX	CPC.5/.75	3/4x12PP	TBSAFETY	
	3	1	3	3	1	3	

110' ROHN 45G
 All parts shown in table are included when ordering
 Part No: 45G110R110

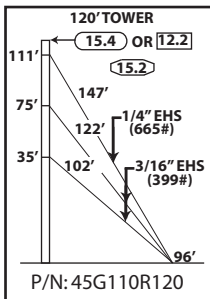

TOWER PARTS INCLUDED	45G	45AG2	BPC45G	GA45GD	FDNS		
	11	1	1	3	BASE	ANCHOR	
GUYS & CONNECTIONS INCLUDED	3/16EHS	1/4EHS	BG2142	BG2144	5/16THH	3/8THH	1/2TBE&J
	725'	475'	12	6	12	6	9
ANCHORS & GROUNDING INCLUDED	GAC3455TOP	AGK1GGX	BGK3GGX	CPC.5/.75	3/4x12PP	TBSAFETY	
	3	1	3	3	1	3	

120' ROHN 45G
 All parts shown in table are included when ordering
 Part No: 45G110R120

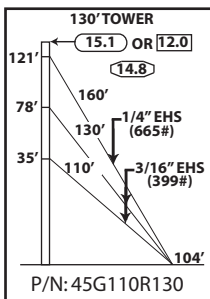

TOWER PARTS INCLUDED	45G	45AG2	BPC45G	GA45GD	FDNS		
	12	1	1	3	BASE	ANCHOR	
GUYS & CONNECTIONS INCLUDED	3/16EHS	1/4EHS	BG2142	BG2144	5/16THH	3/8THH	1/2TBE&J
	775'	525'	12	6	12	6	9
ANCHORS & GROUNDING INCLUDED	GAC3455TOP	AGK1GGX	BGK3GGX	CPC.5/.75	3/4x12PP	TBSAFETY	
	3	1	3	3	1	3	

130' ROHN 45G
 All parts shown in table are included when ordering
 Part No: 45G110R130



STANDARD DESIGN - 45G

110MPH REV. G, 90MPH REV. F

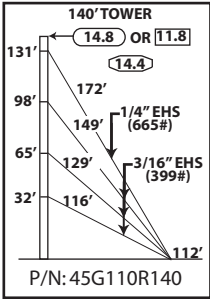

TOWER PARTS INCLUDED	45G	45AG2	BPC45G	GA45GD	FDNS		
	13	1	1	4	BASE CB1G	ANCHOR AB2	
GUYS & CONNECTIONS INCLUDED	3/16EHS	1/4EHS	BG2142	BG2144	5/16THH	3/8THH	1/2TBE&J
	1275'	550'	18	6	18	6	12
ANCHORS & GROUNDING INCLUDED	GAC3455TOP	AGK1GGX	BGK3GGX	CPC.5/.75	3/4x12PP	TBSAFETY	
	3	1	3	3	1	3	

140' ROHN 45G
All parts shown in table are included when ordering
Part No: 45G110R140

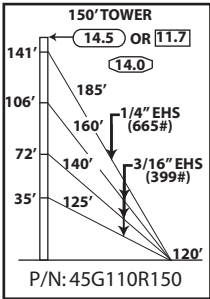

TOWER PARTS INCLUDED	45G	45AG2	BPC45G	GA45GD	FDNS		
	14	1	1	4	BASE CB1G	ANCHOR AB2	
GUYS & CONNECTIONS INCLUDED	3/16EHS	1/4EHS	BG2142	BG2144	5/16THH	3/8THH	1/2TBE&J
	1375'	600'	18	6	18	6	12
ANCHORS & GROUNDING INCLUDED	GAC3455TOP	AGK1GGX	BGK3GGX	CPC.5/.75	3/4x12PP	TBSAFETY	
	3	1	3	3	1	3	

150' ROHN 45G
All parts shown in table are included when ordering
Part No: 45G110R150

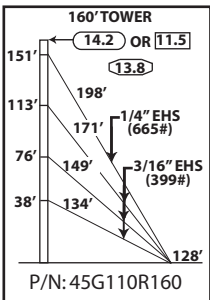

TOWER PARTS INCLUDED	45G	45AG2	BPC45G	GA45GD	FDNS		
	15	1	1	4	BASE CB2G	ANCHOR AB2	
GUYS & CONNECTIONS INCLUDED	3/16EHS	1/4EHS	BG2142	BG2144	5/16THH	3/8THH	1/2TBE&J
	1450'	650'	18	6	18	6	12
ANCHORS & GROUNDING INCLUDED	GAC3455TOP	AGK1GGX	BGK3GGX	CPC.5/.75	3/4x12PP	TBSAFETY	
	3	1	3	3	1	3	

160' ROHN 45G
All parts shown in table are included when ordering
Part No: 45G110R160

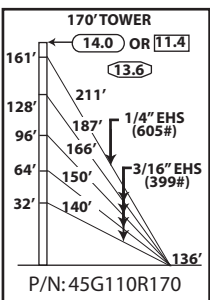

TOWER PARTS INCLUDED	45G	45AG2	BPC45G	GA45GD	FDNS		
	16	1	1	5	BASE CB2G	ANCHOR AB3	
GUYS & CONNECTIONS INCLUDED	3/16EHS	1/4EHS	BG2142	BG2144	5/16THH	3/8THH	5/8TBE&J
	2050'	675'	24	6	24	6	15
ANCHORS & GROUNDING INCLUDED	GAC5655TOP	AGK1GGX	BGK3GGX	CPC1/1.25	3/4x12PP	TBSAFETY	
	3	1	3	3	1	3	

170' ROHN 45G
All parts shown in table are included when ordering
Part No: 45G110R170

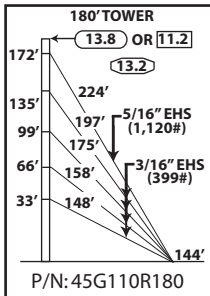

TOWER PARTS INCLUDED	45G	45GL2*	BPC45G	GA45GD	APL45G	FDNS	
	17	1	1	5	1	BASE CB2G	ANCHOR AB3
GUYS & CONNECTIONS INCLUDED	3/16EHS	142265	BG2142	BG2146	5/16THH	7/16THH	5/8TBE&J
	2175'	725'	24	6	24	6	15
ANCHORS & GROUNDING INCLUDED	GAC5655TOP	AGK1GGX	BGK3GGX	CPC1/1.25	3/4x12PP	TBSAFETY	
	3	1	3	3	1	3	

180' ROHN 45G
All parts shown in table are included when ordering
Part No: 45G110R180

* 45GL2 Lug section required for 5/16" guy



STANDARD DESIGN - 45G
110MPH REV. G, 90MPH REV. F

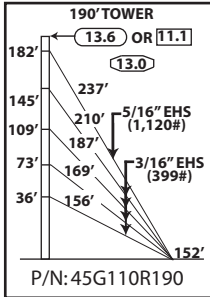

TOWER PARTS INCLUDED	45G	45GL2*	BPC45G	GA45GD	APL45G	FDNS	
	18	1	1	5	1	BASE	ANCHOR
GUYS & CONNECTIONS INCLUDED	3/16EHS	142265	BG2142	BG2146	5/16THH	7/16THH	5/8TBE&J
	2300'	725'	24	6	24	6	15
ANCHORS & GROUNDING INCLUDED	GAC5655TOP	AGK1GGX	BGK3GGX	CPC1/1.25	3/4x12PP	TBSAFETY	
	3	1	3	3	1	3	

190' ROHN 45G
All parts shown in table are included when ordering
Part No: 45G110R190

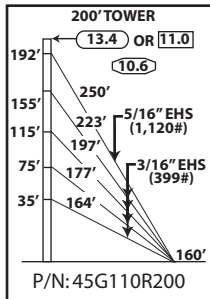

TOWER PARTS INCLUDED	45G	45GL2*	BPC45G	GA45GD	APL45G	FDNS	
	19	1	1	5	1	BASE	ANCHOR
GUYS & CONNECTIONS INCLUDED	3/16EHS	142265	BG2142	BG2146	5/16THH	7/16THH	5/8TBE&J
	2425'	800'	24	6	24	6	15
ANCHORS & GROUNDING INCLUDED	GAC5655TOP	AGK1GGX	BGK3GGX	CPC1/1.25	3/4x12PP	TBSAFETY	
	3	1	3	3	1	3	

200' ROHN 45G
All parts shown in table are included when ordering
Part No: 45G110R200

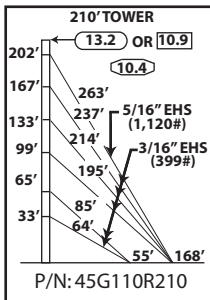

TOWER PARTS INCLUDED	45G	BPC45G	45GL2*	APL45G	GA45GD	BASE	INNER ANCHOR	OUTER ANCHOR
	20	1	1	1	6	CB3G	AB2	AB3
GUYS & CONNECTIONS INCLUDED	3/16EHS	142265	BG2142	BG2146	5/16THH			
	2550'	850'	30	6	30			
	7/16THH	1/2TBE&J	5/8TBE&J	TBSAFETY	3/4x12PP			
	6	6	12	6	1			
ANCHORS & GROUNDING INCLUDED	GAC5655TOP	GAC3455TOP	AGK1GGX	BGK3GGX	CPC.5/.75	CPC1/1.25		
	3	3	2	3	3	3		

210' ROHN 45G
All parts shown in table are included when ordering
Part No: 45G110R210

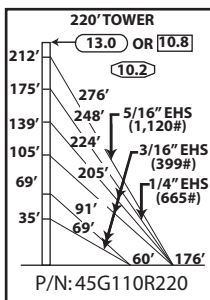

TOWER PARTS INCLUDED	45G	BPC45G	45GL2*	APL45G	GA45GD	BASE	INNER ANCHOR	OUTER ANCHOR
	21	1	1	1	6	CB3G	AB2	AB3
GUYS & CONNECTIONS INCLUDED	3/16EHS	1/4EHS	142265	BG2142	BG2144	BG2146		
	1875'	800'	900'	24	6	6		
	5/16THH	3/8THH	7/16THH	1/2TBE&J	5/8TBE&J	TBSAFETY		
	24	6	6	6	12	6		
ANCHORS & GROUNDING INCLUDED	GAC5655TOP	GAC3455TOP	AGK1GGX	BGK3GGX	CPC.5/.75	CPC1/1.25	3/4X12PP	
	3	3	2	3	3	3	1	

220' ROHN 45G
All parts shown in table are included when ordering
Part No: 45G110R220

* 45GL2 Lug section required for 5/16" guy



STANDARD DESIGN - 45G
110MPH REV. G, 90MPH REV. F

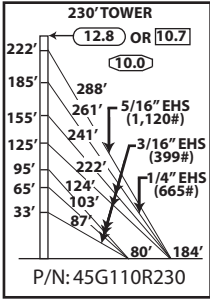

TOWER PARTS INCLUDED	45G	BPC45G	APL45G	GA45GD	45GL2*	BASE	INNER ANCHOR	OUTER ANCHOR
		22	1	1	7	1	CB3G	AB2
GUYS & CONNECTIONS INCLUDED	3/16EHS	1/4EHS	142265	BG2142	BG2144	BG2146		
	2475'	850'	925'	30	6	6		
	5/16THH	3/8THH	7/16THH	1/2TBE&J	5/8TBE&J	TBSAFETY		
	30	6	6	9	12	6		
ANCHORS & GROUNDING INCLUDED	GAC3455TOP	GAC5655TOP	AGK1GGX	BGK3GGX	CPC.5/1.75	CPC1/1.25	3/4x12PP	
	3	3	2	3	3	3	1	

230' ROHN 45G
All parts shown in table are included when ordering
Part No: 45G110R230

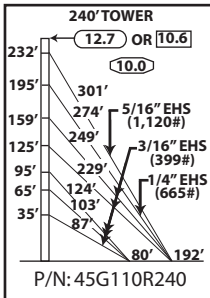

TOWER PARTS INCLUDED	45G	BPC45G	APL45G	GA45GD	45GL2*	BASE	INNER ANCHOR	OUTER ANCHOR
		23	1	1	7	1	CB3G	AB2
GUYS & CONNECTIONS INCLUDED	3/16EHS	1/4EHS	142265	BG2142	BG2144	BG2146		
	2525'	875'	975'	30	6	6		
	5/16THH	3/8THH	7/16THH	1/2TBE&J	5/8TBE&J	TBSAFETY		
	30	6	6	9	12	6		
ANCHORS & GROUNDING INCLUDED	GAC3455TOP	GAC5655TOP	AGK1GGX	BGK3GGX	CPC.5/1.75	CPC1/1.25	3/4x12PP	
	3	3	2	3	3	3	1	

240' ROHN 45G
All parts shown in table are included when ordering
Part No: 45G110R240

* 45GL2 Lug section required for 5/16" guy



STANDARD DESIGN - 45G
130MPH REV. G, 110MPH REV. F

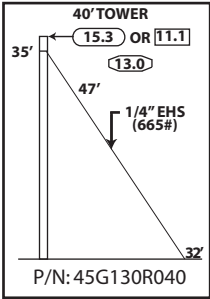

TOWER PARTS INCLUDED	45G	45AG2	BPC45G	GA45GD	FDNS	
					BASE	ANCHOR
	3	1	1	1	CB1G	AB2
GUYS & CONNECTIONS INCLUDED	1/4EHS	BG2144	3/8THH	1/2TBE&J	TBSAFETY	
	150'	6	6	3	3	
ANCHORS & GROUNDING INCLUDED	GAC3455TOP	AGK1GGX	BGK3GGX	CPC.5/.75	3/4x12PP	
	3	1	3	3	1	

40' ROHN 45G
All parts shown in table are included when ordering
Part No: 45G130R040

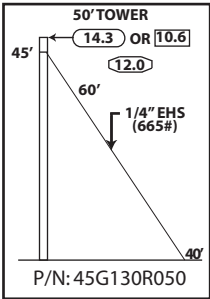

TOWER PARTS INCLUDED	45G	45AG2	BPC45G	GA45GD	FDNS	
					BASE	ANCHOR
	4	1	1	1	CB1G	AB2
GUYS & CONNECTIONS INCLUDED	1/4EHS	BG2144	3/8THH	1/2TBE&J	TBSAFETY	
	200'	6	6	3	3	
ANCHORS & GROUNDING INCLUDED	GAC3455TOP	AGK1GGX	BGK3GGX	CPC.5/.75	3/4x12PP	
	3	1	3	3	1	

50' ROHN 45G
All parts shown in table are included when ordering
Part No: 45G130R050

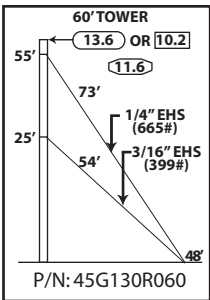

TOWER PARTS INCLUDED	45G	45AG2	BPC45G	GA45GD	FDNS		
					BASE	ANCHOR	
	5	1	1	2	CB1G	AB2	
GUYS & CONNECTIONS INCLUDED	3/16EHS	1/4EHS	BG2142	BG2144	5/16THH	3/8THH	1/2TBE&J
	175'	250'	6	6	6	6	6
ANCHORS & GROUNDING INCLUDED	GAC3455TOP	AGK1GGX	BGK3GGX	CPC.5/.75	3/4x12PP	TBSAFETY	
	3	1	3	3	1	3	

60' ROHN 45G
All parts shown in table are included when ordering
Part No: 45G130R060

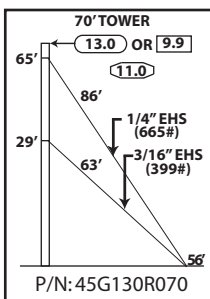

TOWER PARTS INCLUDED	45G	45AG2	BPC45G	GA45GD	FDNS		
					BASE	ANCHOR	
	6	1	1	2	CB1G	AB2	
GUYS & CONNECTIONS INCLUDED	3/16EHS	1/4EHS	BG2142	BG2144	5/16THH	3/8THH	1/2TBE&J
	225'	275'	6	6	6	6	6
ANCHORS & GROUNDING INCLUDED	GAC3455TOP	AGK1GGX	BGK3GGX	CPC.5/.75	3/4x12PP	TBSAFETY	
	3	1	3	3	1	3	

70' ROHN 45G
All parts shown in table are included when ordering
Part No: 45G130R070

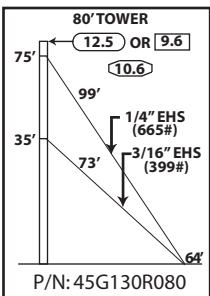

TOWER PARTS INCLUDED	45G	45AG2	BPC45G	GA45GD	FDNS		
					BASE	ANCHOR	
	7	1	1	2	CB1G	AB2	
GUYS & CONNECTIONS INCLUDED	3/16EHS	1/4EHS	BG2142	BG2144	5/16THH	3/8THH	1/2TBE&J
	250'	325'	6	6	6	6	6
ANCHORS & GROUNDING INCLUDED	GAC3455TOP	AGK1GGX	BGK3GGX	CPC.5/.75	3/4x12PP	TBSAFETY	
	3	1	3	3	1	3	

80' ROHN 45G
All parts shown in table are included when ordering
Part No: 45G130R080



STANDARD DESIGN - 45G 130MPH REV. G, 110MPH REV. F

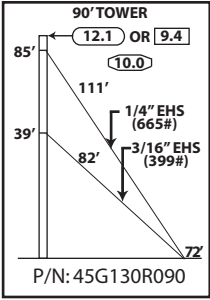

TOWER PARTS INCLUDED	45G	45AG2	BPC45G	GA45GD	FDNS		
	8	1	1	2	BASE CB1G	ANCHOR AB2	
GUYS & CONNECTIONS INCLUDED	3/16EHS	1/4EHS	BG2142	BG2144	5/16THH	3/8THH	1/2TBE&J
	275'	375'	6	6	6	6	6
ANCHORS & GROUNDING INCLUDED	GAC3455TOP	AGK1GGX	BGK3GGX	CPC.5/.75	3/4x12PP	TBSAFETY	
	3	1	3	3	1	3	

90' ROHN 45G
All parts shown in table are included when ordering
Part No: 45G130R090

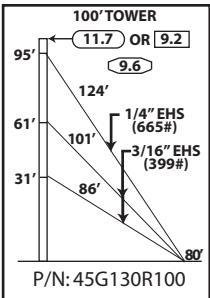

TOWER PARTS INCLUDED	45G	45AG2	BPC45G	GA45GD	FDNS		
	9	1	1	3	BASE CB1G	ANCHOR AB2	
GUYS & CONNECTIONS INCLUDED	3/16EHS	1/4EHS	BG2142	BG2144	5/16THH	3/8THH	1/2TBE&J
	600'	400'	12	6	12	6	9
ANCHORS & GROUNDING INCLUDED	GAC3455TOP	AGK1GGX	BGK3GGX	CPC.5/.75	3/4x12PP	TBSAFETY	
	3	1	3	3	1	3	

100' ROHN 45G
All parts shown in table are included when ordering
Part No: 45G130R100

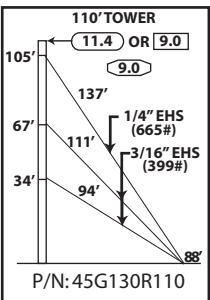

TOWER PARTS INCLUDED	45G	45AG2	BPC45G	GA45GD	FDNS		
	10	1	1	3	BASE CB1G	ANCHOR AB2	
GUYS & CONNECTIONS INCLUDED	3/16EHS	1/4EHS	BG2142	BG2144	5/16THH	3/8THH	1/2TBE&J
	675'	450'	12	6	12	6	9
ANCHORS & GROUNDING INCLUDED	GAC3455TOP	AGK1GGX	BGK3GGX	CPC.5/.75	3/4x12PP	TBSAFETY	
	3	1	3	3	1	3	

110' ROHN 45G
All parts shown in table are included when ordering
Part No: 45G130R110

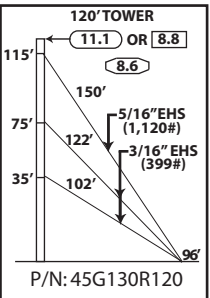

TOWER PARTS INCLUDED	45G	45GL5*	BPC45G	GA45GD	APL45G	FDNS		
	11	1	1	3	1	BASE CB1G	ANCHOR AB2	
GUYS & CONNECTIONS INCLUDED	3/16EHS	142265	BG2142	BG2146	5/16THH	7/16THH	1/2TBE&J	5/8TBE&J
	725'	500'	12	6	12	6	6	3
ANCHORS & GROUNDING INCLUDED	GAC3455TOP	AGK1GGX	BGK3GGX	CPC.5/.75	3/4x12PP	TBSAFETY		
	3	1	3	3	1	3		

120' ROHN 45G
All parts shown in table are included when ordering
Part No: 45G130R120

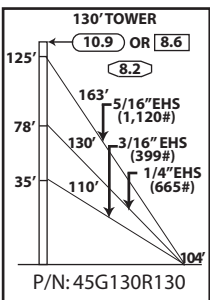

TOWER PARTS INCLUDED	45G	45GL5*	BPC45G	GA45GD	APL45G	FDNS	
	12	1	1	3	1	BASE CB2G	ANCHOR AB3
GUYS & CONNECTIONS INCLUDED	3/16EHS	1/4EHS	142265	BG2142	BG2144	BG2146	
	350'	425'	525'	6	6	6	
	5/16THH	3/8THH	7/16THH	5/8TBE&J	TBSAFETY		
ANCHORS & GROUNDING INCLUDED	GAC5655TOP	AGK1GGX	BGK3GGX	CPC1/1.25	3/4x12PP		
	3	1	3	3	1		

130' ROHN 45G
All parts shown in table are included when ordering
Part No: 45G130R130

* 45GL5 Lug section required for 5/16" guy



STANDARD DESIGN - 45G
130MPH REV. G, 110MPH REV. F

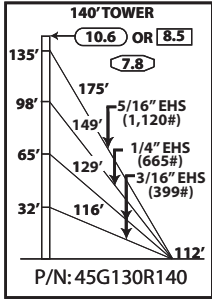

TOWER PARTS INCLUDED	45G	45GL5*	BPC45G	GA45GD	APL45G	FDNS	
						BASE	ANCHOR
	13	1	1	4	1	CB2G	AB3
GUYS & CONNECTIONS INCLUDED	3/16EHS	1/4EHS	142265	BG2142	BG2144	BG2146	
	800'	475'	575'	12	6	6	
	5/16THH	3/8THH	7/16THH	5/8TBE&J	TBSAFETY		
	12	6	6	12	3		
ANCHORS & GROUNDING INCLUDED	GAC5655TOP	AGK1GGX	BGK3GGX	CPC1/1.25	3/4x12PP		
	3	1	3	3	1		

140' ROHN 45G
All parts shown in table are included when ordering
Part No: 45G130R140

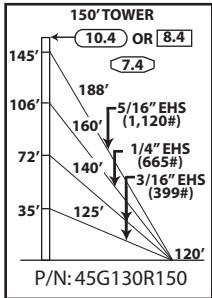

TOWER PARTS INCLUDED	45G	45GL5*	BPC45G	GA45GD	APL45G	FDNS	
						BASE	ANCHOR
	14	1	1	4	1	CB2G	AB3
GUYS & CONNECTIONS INCLUDED	3/16EHS	1/4EHS	142265	BG2142	BG2144	BG2146	
	850'	525'	600'	12	6	6	
	5/16THH	3/8THH	7/16THH	5/8TBE&J	TBSAFETY		
	12	6	6	12	3		
ANCHORS & GROUNDING INCLUDED	GAC5655TOP	AGK1GGX	BGK3GGX	CPC1/1.25	3/4x12PP		
	3	1	3	3	1		

150' ROHN 45G
All parts shown in table are included when ordering
Part No: 45G130R150

* 45GL5 Lug section required for 5/16" guy

PARTS & ACCESSORIES

<p>TOP SECTION 45AG</p>	<p>TOP SECTION 45AG1</p>	<p>TOP SECTION 45AG2</p>	<p>TOP SECTION 45AG3</p>
------------------------------------	-------------------------------------	-------------------------------------	-------------------------------------

<p>TOP SECTION 45AG4</p> <p>TOP PLATE HOLE PATTERN IS THE SAME AS BPL45G.</p>	<p>TOP SECTION 45AG5</p>	<p>BEARING PLATE BPL45G</p> <p>CONVERTS STANDARD SECTION TO A TOP SECTION. HOLE PATTERN FITS TB3 (2" O.D.) AND TB4 (3" O.D.) THRUST BEARINGS.</p>	<p>TOP PLATE APL45G</p> <p>FOR MOUNTING BEACON OR LIGHTNING ROD.</p>
------------------------------------------------------------------------------------------	-------------------------------------	--------------------------------------------------------------------------------------------------------------------------------------------------------------	---------------------------------------------------------------------------------

<p>TOP MOUNT</p> <ul style="list-style-type: none"> 45TDMKD - NO MAST 45TDM2S3KD - 2 3/8" O.D. MAST 45TDM2S53KD - 2 7/8" O.D. MAST 45TDM3S3KD - 3 1/2" O.D. MAST 45TDM3S53KD - 4" O.D. MAST 45TDM4S3KD - 4 1/2" O.D. MAST <p>MOUNTING TUBE PROVIDED IS 7' LONG.</p>	<p>ACCESSORY SHELF AS455G</p> <p>FOR MOUNTING MANY POPULAR ROTORS. FIELD DRILLING MAY BE NECESSARY FOR SOME ROTORS.</p>	<p>LIGHTNING ROD LRCL</p> <p>5' COPPER CLAD MOUNTS TO APL45G.</p>
----------------------------------------------------------------------------------------------------------------------------------------------------------------------------------------------------------------------------------------------------------------------------------------------------------------------------------------	------------------------------------------------------------------------------------------------------------------------------------	------------------------------------------------------------------------------



PARTS & ACCESSORIES

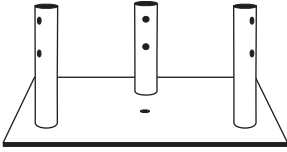

**CONCRETE BASE PLATE
BPC45G***

FOR USE WITH 3/4X12PP PIER PIN
EMBEDDED IN CONCRETE.

CONCRETE BASE PLATE IS TO BE
USED FOR BRACKETED AND
GUYED APPLICATIONS ONLY.



**PIER PIN
3/4X12PP**

FOR USE WITH BPC45G
EMBEDDED IN CONCRETE.

PIER PIN MUST BE ORDERED
SEPARATELY, UNLESS BEING
PURCHASED AS PART OF
A COMPLETE TOWER KIT.

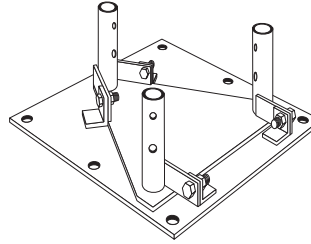

**HINGED BASE PLATE
BPH45G***

FOR USE WITH 5/8X12BB BASE BOLTS
(ORDERED SEPARATELY).
HINGED TO ALLOW TOWER TO
BE ROTATED UP FROM BASE
DURING INSTALLATION.

HINGED BASE PLATE IS TO BE
USED FOR BRACKETED AND GUYED
APPLICATIONS ONLY.

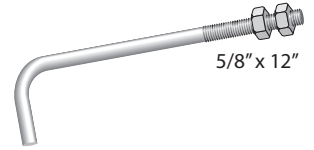

5/8" x 12"

**BASE BOLT
5/8X12BB**

FOR USE WITH BPH45G
(6) REQUIRED, ORDERED SEPARATELY.



**TAPERED BASE
45TG***

CAN BE USED WITH A4197L
BASE INSULATOR OR WITH
3/4X12PP, ORDERED SEPARATELY.

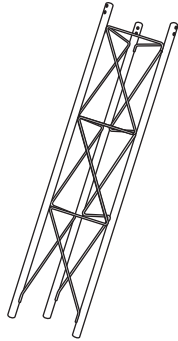

**5' SHORT BASE
SB45G**

FOR EMBEDMENT IN CONCRETE.

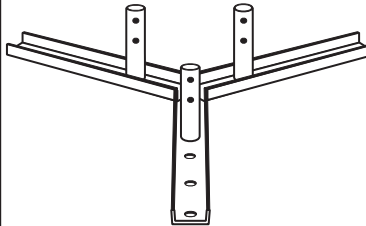

**FLAT ROOF MOUNT
FR45G***

BOLTS DIRECTLY TO FLAT ROOF SURFACE.

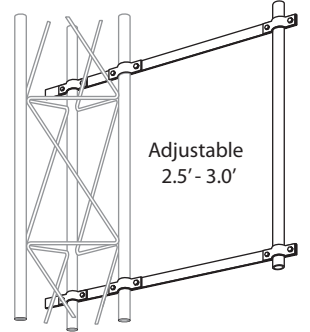

Adjustable
2.5' - 3.0'

**SIDE ARM BRACKET
SA253UA**

MOUNTING TUBE PROVIDED IS 3' LONG,
2 - 1/4" O.D.

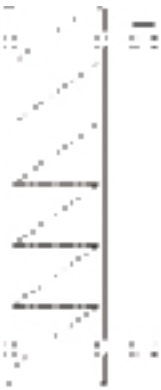

DISH MOUNT

VY4311A2 - 2 3/8" O.D.
VY4311A - 4 1/2" O.D.
MAST TUBE PROVIDED IS 5' LONG.

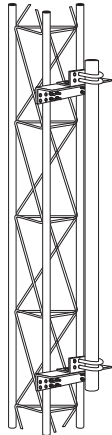

FACE MOUNT

DM45G2 - 2 3/8" O.D. 5' LONG
DM454 - 4 1/2" O.D. 5' LONG

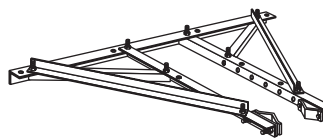

**HEAVY DUTY UNIVERSAL
HOUSE BRACKET**

H BUTVRO
ADJUSTABLE TO POSITION TOWER
18" - 36" FROM WALL.

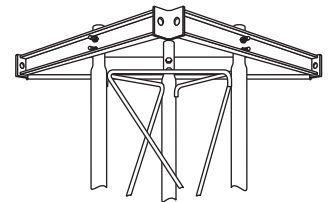

**TORQUE ARM STABILIZER
ASSEMBLY
TA45**

ANTI-TWIST DEVICE LOCATED IN THE
AREA OF ANTENNAS. PROVIDES SIX-WAY
GUYING. BOLTS TO TOWER AT ANY
SECTION JOINT. ATTACHED WITH
JOINT BOLTS. MUST BE INSTALLED AS
SECTIONS ARE JOINED TOGETHER.

* TOWERS MOUNTED ON THESE BASES MUST BE BRACKETED OR GUYED AT ALL TIMES. TEMPORARY STEEL GUYING MAY ALSO BE NECESSARY DURING INSTALLATION AND DISMANTLING.



PARTS & ACCESSORIES

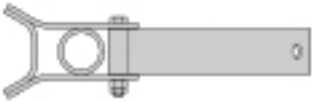

TORQUE BAR
TB45D
OPTIONAL, FOR USE WITH GA45GD.
REQUIRES (1) 3/8" SHACKLE
FOR EACH BAR.

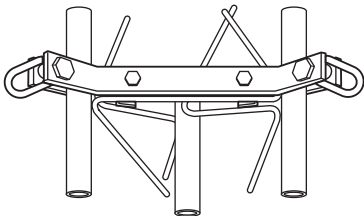

GUY BRACKET
GA45GD
MOUNTS TO TOWER AT ANY
HORIZONTAL BRACE.

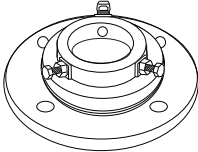

THRUST BEARING
TB3 - SUPPORTS UP TO 2" O.D. MAST.
TB4 - SUPPORTS UP TO 3" O.D. MAST.
MOUNTS TO BPL45G AND 45AG4.

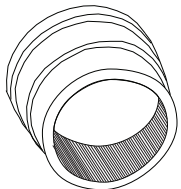

TOWER BUSHING
TB50 - 1-1/4" I.D. X 2" O.D.
TB75 - 1-1/2" I.D. X 2" O.D.
FOR USE ON 45AG TOP SECTION

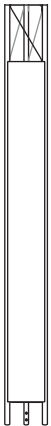

ANTI-CLIMB PANELS
VW913A
THREE ANTI-CLIMB PANELS BOLT
TO STANDARD TOWER SECTION.

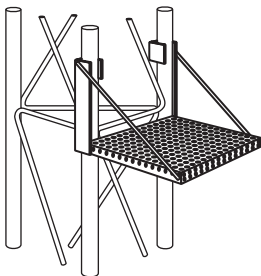

WORK PLATFORM
WP45G
SNAPS INTO PLACE AT ANY LEVEL.
NO BOLTS REQUIRED.



SAFETY RING
SR245
SNAPS INTO PLACE AT ANY LEVEL.
NO BOLTS REQUIRED.

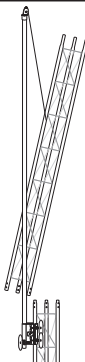

ERECTION FIXTURE
EF2545 - 2 1/2" SHEAVE WITH
3/8" I.D. GROOVE.
NOTE: ERECTION FIXTURES ARE FOR
LIFTING ONE 10' SECTION AT A TIME AND
ARE NOT INTENDED FOR THE LIFTING OF
PERSONNEL.



CLIMBING HARNESS
TTFBH-4D
JOURNEYMAN HARNESS
TTFBH-C/P
PROFESSIONAL HARNESS



SAFETY CABLE SLIDER WITH CARABINEER
TT-WG-500-W/SMC

SAFETY CABLE SYSTEM ORDERING INFORMATION

TOWER HEIGHT	PART NUMBER
50'	TT0504555
100'	TT1004555
150'	TT1504555
200'	TT2004555
250'	TT2504555
300'	TT3004555
350'	TT3504555

SAFETY CABLE SLIDER AND CLIMBING HARNESS MUST BE ORDERED SEPARATELY.



ANCHOR INFORMATION

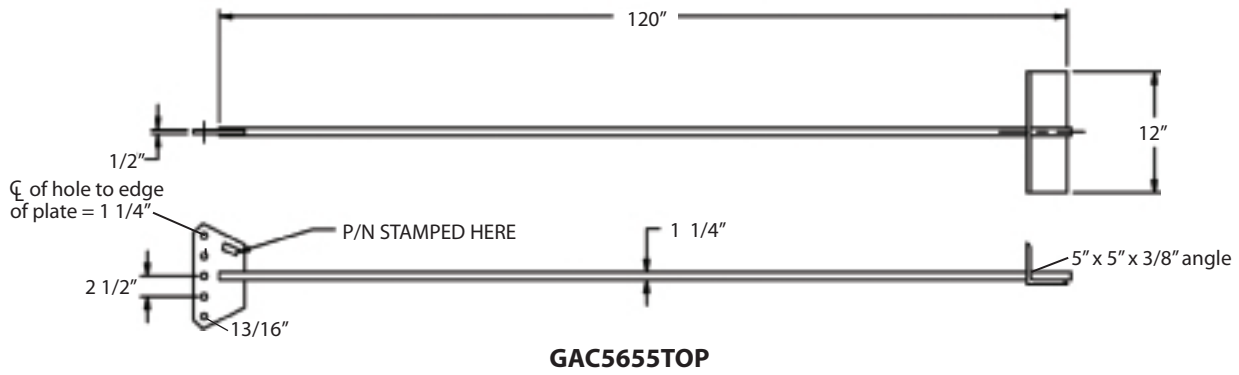
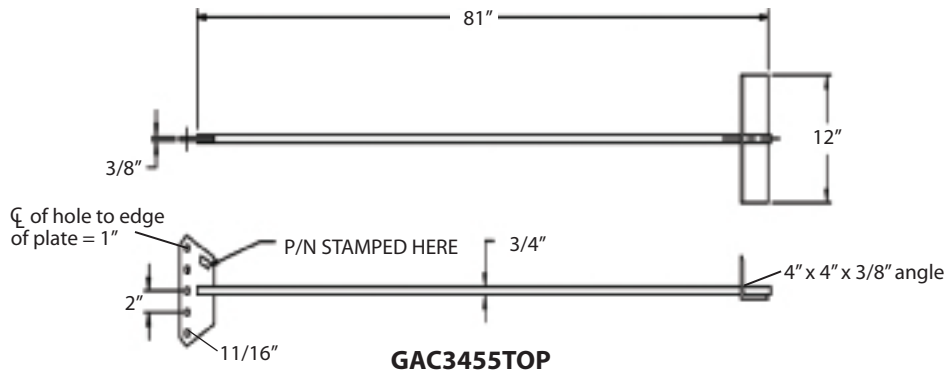

REV G
ANCHOR GROUNDING
AGK1GGX

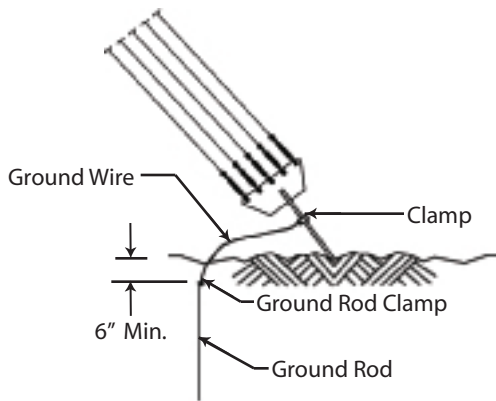

REV G
BASE GROUNDING
BGK3GGX

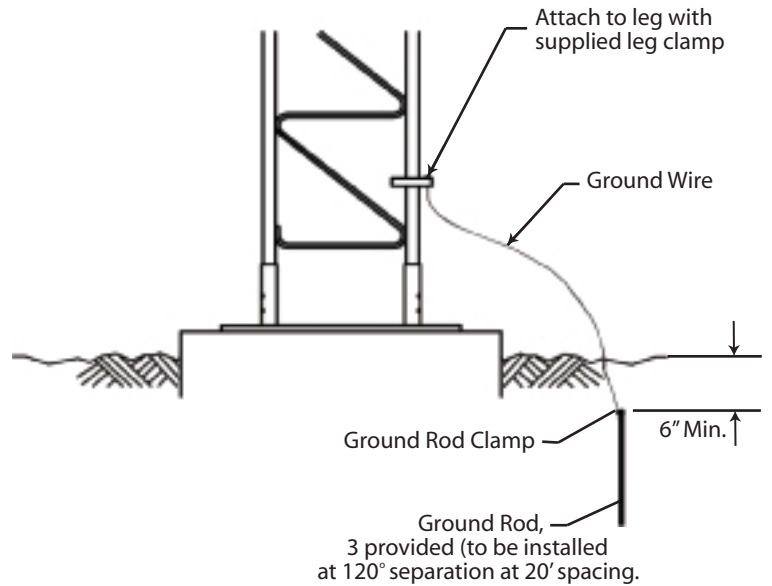

STANDARD ANCHOR BLOCKS

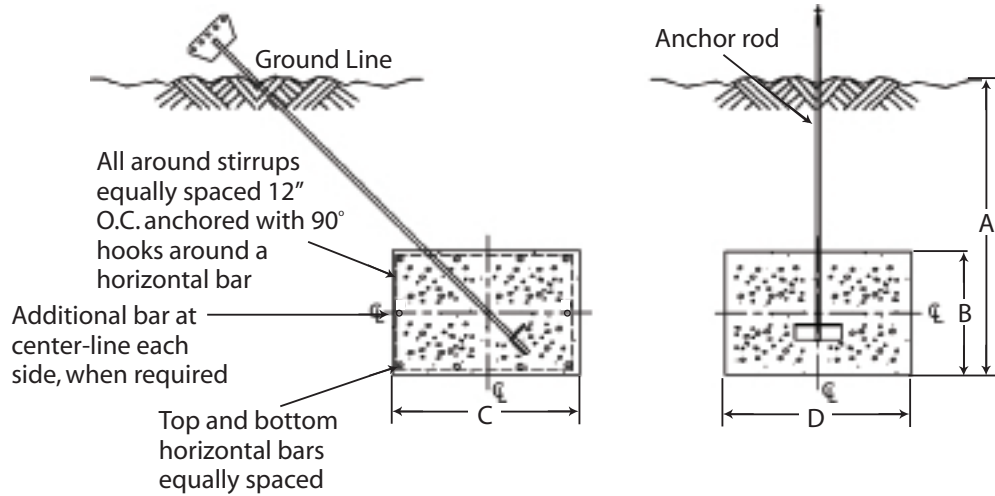

Refer to page 68 for anchor rod installation angles.

Block	Anchor Dimensions (in.)				Horizontal Bars (Qty. & Size)	Stirrup Size & Spacing	Concrete Vol. (Cu. Yds.)
	A	B	C	D			
AB2	4' - 0"	1' - 6"	4' - 0"	6' - 0"	(5) #6 Bars, Top Layer (5) #6 Bars, Bottom Layer (0) Additional Bar, Each Side	#3 @ 12" O.C.	1.33 Per Block 4.0 Total for 3
AB3	6' - 0"	1' - 6"	3' - 0"	6' - 0"	(4) #6 Bars, Top Layer (4) #6 Bars, Bottom Layer (0) Additional Bar, Each Side	#3 @ 12" O.C.	1.0 Per Block 3.0 Total for 3
AB4	6' - 0"	1' - 6"	4' - 0"	9' - 0"	(5) #6 Bars, Top Layer (5) #6 Bars, Bottom Layer (0) Additional Bar, Each Side	#4 @ 12" O.C.	2.0 Per Block 6.0 Total for 3
AB5	8' - 0"	2' - 0"	3' - 0"	10' - 0"	(4) #7 Bars, Top Layer (4) #7 Bars, Bottom Layer (1) Additional Bar, Each Side	#4 @ 12" O.C.	2.22 Per Block 6.7 Total for 3
AB6	8' - 0"	2' - 0"	4' - 0"	10' - 0"	(5) #7 Bars, Top Layer (5) #7 Bars, Bottom Layer (1) Additional Bar, Each Side	#4 @ 12" O.C.	2.96 Per Block 8.9 Total for 3



ANCHOR ROD INSTALLATION ANGLES

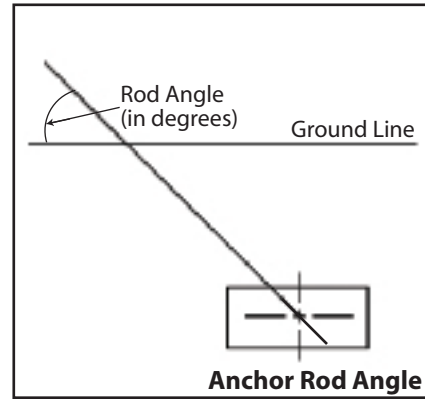
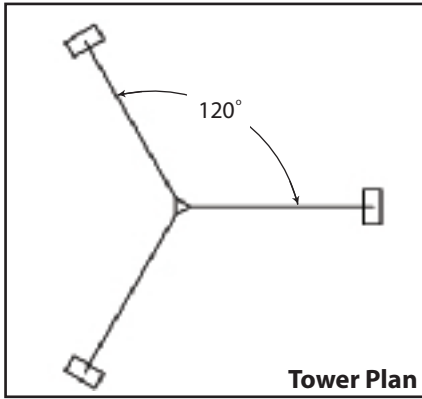

45G 90MPH				
Tower Height	Inner Rod Number	Inner Rod Angle	Outer Rod Number	Outer Rod Angle
40'	GAC3455TOP	45	-	-
50'	GAC3455TOP	46	-	-
60'	GAC3455TOP	43	-	-
70'	GAC3455TOP	43	-	-
80'	GAC3455TOP	41	-	-
90'	GAC3455TOP	42	-	-
100'	GAC3455TOP	42	-	-
110'	GAC3455TOP	40	-	-
120'	GAC3455TOP	39	-	-
130'	GAC3455TOP	40	-	-
140'	GAC3455TOP	39	-	-
150'	GAC3455TOP	38	-	-
160'	GAC3455TOP	37	-	-
170'	GAC3455TOP	38	-	-
180'	GAC3455TOP	38	-	-
190'	GAC3455TOP	36	-	-
200'	GAC3455TOP	36	-	-
210'	GAC3455TOP	40	GAC3455TOP	44
220'	GAC3455TOP	40	GAC3455TOP	44
230'	GAC3455TOP	42	GAC3455TOP	42
240'	GAC3455TOP	42	GAC3455TOP	41
250'	GAC3455TOP	40	GAC3455TOP	43
260'	GAC3455TOP	40	GAC3455TOP	42
270'	GAC3455TOP	38	GAC3455TOP	43
280'	GAC3455TOP	38	GAC3455TOP	43
290'	GAC3455TOP	38	GAC3455TOP	44
300'	GAC3455TOP	38	GAC3455TOP	43

45G 110MPH				
Tower Height	Inner Rod Number	Inner Rod Angle	Outer Rod Number	Outer Rod Angle
40'	GAC3455TOP	45	-	-
50'	GAC3455TOP	46	-	-
60'	GAC3455TOP	41	-	-
70'	GAC3455TOP	41	-	-
80'	GAC3455TOP	41	-	-
90'	GAC3455TOP	41	-	-
100'	GAC3455TOP	39	-	-
110'	GAC3455TOP	39	-	-
120'	GAC3455TOP	39	-	-
130'	GAC3455TOP	38	-	-
140'	GAC3455TOP	38	-	-
150'	GAC3455TOP	38	-	-
160'	GAC3455TOP	38	-	-
170'	GAC5655TOP	37	-	-
180'	GAC5655TOP	37	-	-
190'	GAC5655TOP	37	-	-
200'	GAC5655TOP	37	-	-
210'	GAC3455TOP	41	GAC5655TOP	42
220'	GAC3455TOP	41	GAC5655TOP	42
230'	GAC3455TOP	38	GAC5655TOP	43
240'	GAC3455TOP	39	GAC5655TOP	43

45G 130MPH		
Tower Height	Rod Number	Rod Angle
40'	GAC3455TOP	48
50'	GAC3455TOP	48
60'	GAC3455TOP	40
70'	GAC3455TOP	40
80'	GAC3455TOP	40
90'	GAC3455TOP	40
100'	GAC3455TOP	38
110'	GAC3455TOP	38
120'	GAC3455TOP	38
130'	GAC5655TOP	38
140'	GAC5655TOP	37
150'	GAC5655TOP	37

STANDARD BASE PIERS

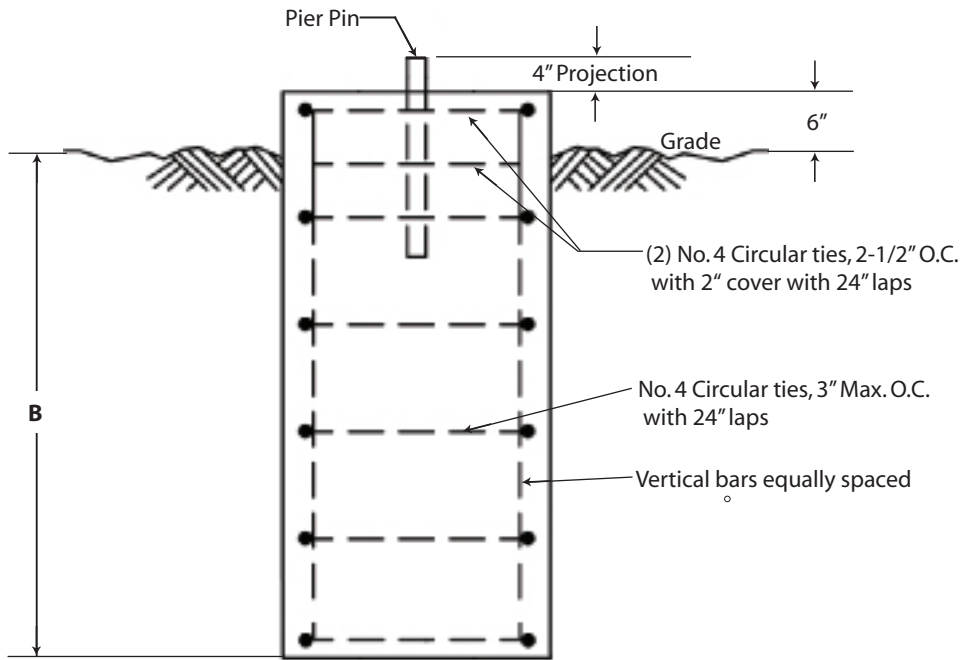

ELEVATION VIEW

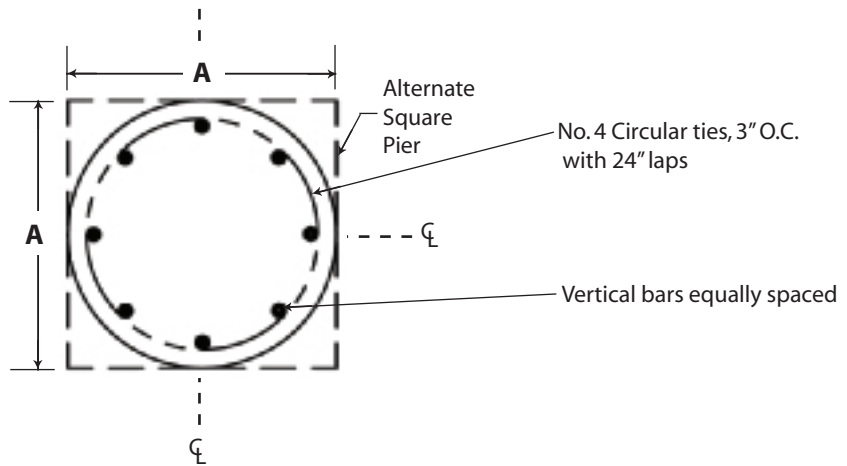

PLAN VIEW

Base	A	B	Concrete Vol. (Cu. Yds.) Round Pier	Vertical Bars (No. & Size)
CB1G*	2' - 6"	4' - 0"	1.0	(8) #7
CB2G	3' - 0"	4' - 0"	1.2	(10) #7
CB3G	3' - 6"	4' - 0"	1.6	(12) #7

* Square pier option must be used for CB1G.



STANDARD 45GSR GUYED TOWER

ROHN 45GSR
The first. The original.

45GSR

GENERAL USE

The 45GSR maintains the utility of the 45G and adds the strength of solid round steel legs. The 45GSR has a strong 4 bolt flange connection, giving connection joints superior strength over typical 1 bolt flange connection systems. The 45GSR is available in heights up to 340'.

FEATURES

- Completely hot-dip galvanized after fabrication
- Built on a 16 3/4" equilateral triangle design
- Heavy solid steel round legs joined by Zig-Zag[®] cross members
- Each section contains all required nuts and bolts shipped with section
- Continuous solid round steel bracing

CAUTION

Mixing copies of ROHN towers with ROHN towers is dangerous and voids all engineering and warranty data supplied by ROHN. Materials used by others are not the same quality and have not been tested or engineered by ROHN. Mixing ROHN tower sections with non-ROHN products may cause tower failure or injury.

Per Rev G requirements, any structure greater than 10' requires a climber safety device. Please see page 92 for ordering information.





STANDARD 45GSR GUYED TOWER SECTIONS

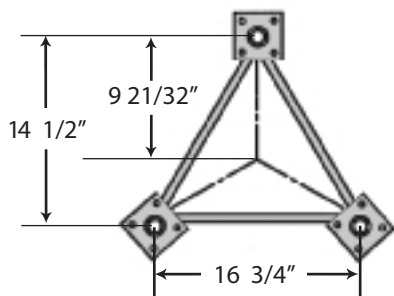

QUICK REFERENCE	
PARTS & ACCESSORIES	PAGE 92
GROUNDING INFORMATION	PAGE 93
FOUNDATION INFORMATION	PAGES 93-97

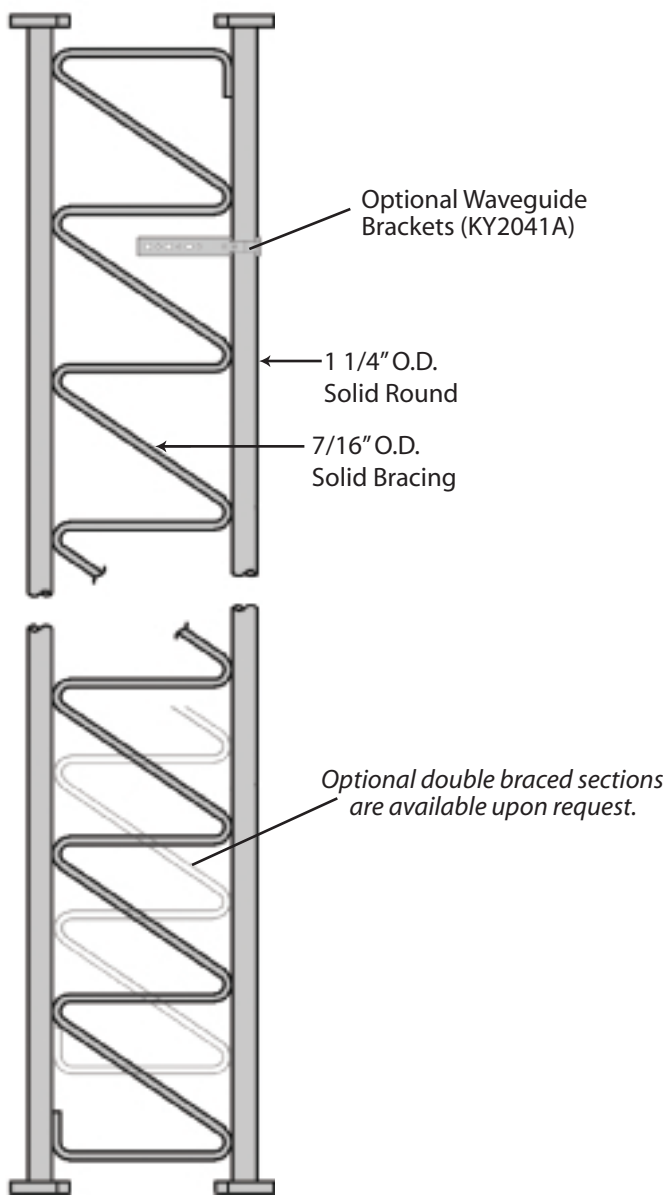

STANDARD SECTION
45GSR10 - 10' Section
45GSR20 - 20' Section

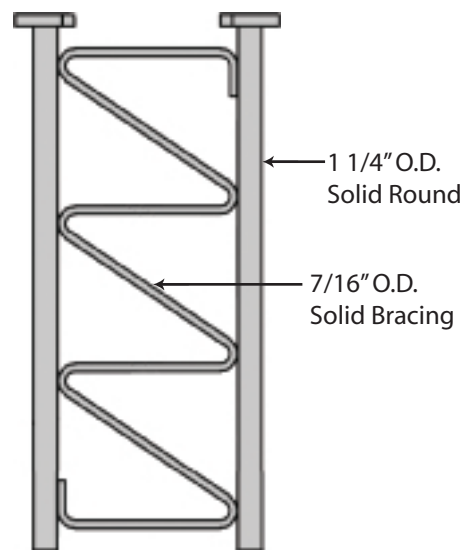

4.3' 45GSR SHORT BASE
45GSRSB

TO BE EMBEDDED IN CONCRETE.



BUYERS GUIDE
STANDARD DESIGNS - 45GSR
90MPH REV. G [3 SECOND GUST]

Design Criteria

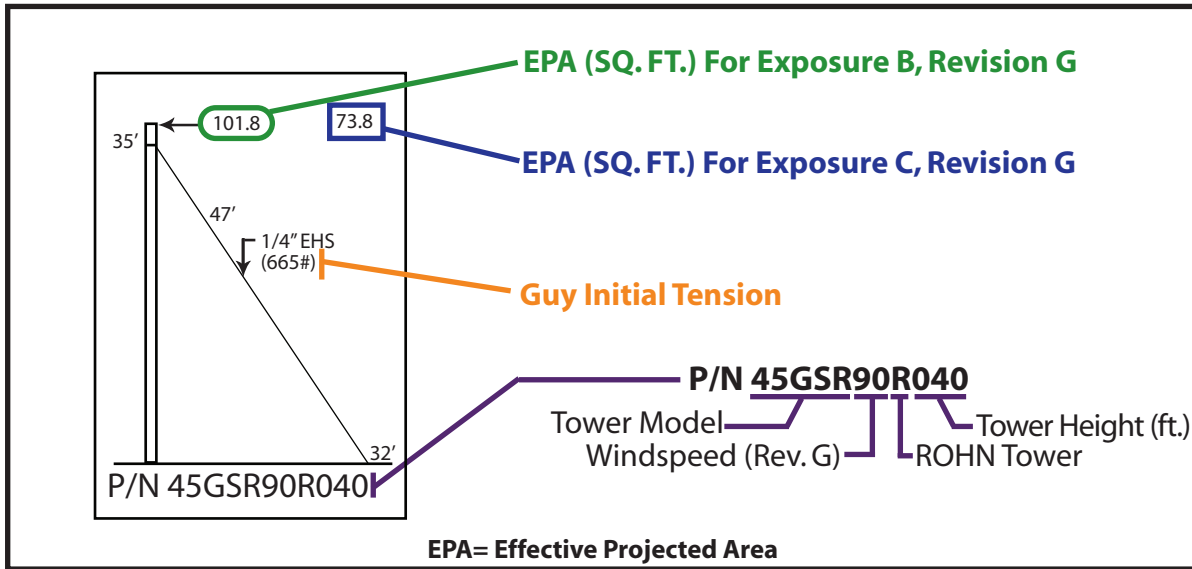

This document is to serve as a guide for sizing and purchasing the 45GSR tower. Tower and foundation installations should be performed by qualified and experienced personnel using assembly drawings provided with each tower.

DESIGN NOTES:

- 1. Tower designs are in accordance with ANSI/TIA-222-G, Class I Structures, Topographic Category 1.
2. Design assumes towers are installed on level ground. Lower EPA values will apply for roof mounted towers or for sites located on unusual terrain.
3. Designs assume two 7/8" diameter lines on each tower face.
4. Anchor radius is from tower base to intersection of anchor rod with ground.
5. Guy chord lengths shown are based on level ground. Initial tensions for guys are shown in () in pounds at 60° Fahrenheit.
6. Antenna and mounts are assumed symmetrically placed at the tower top.

PARTS LIST NOTES:

- 1. Items listed are required for complete guyed towers.
2. Base and anchor foundations listed refer to standard foundation designations.
3. Guys provided with each standard tower are based on level ground conditions with an additional 6% length.
4. Rev G anchor grounding (AGK1GGX) and base grounding (BGK3GGX) are included with the tower material.
5. Assembly drawings and a safety package (P/N: ACWS) are included with each tower.
6. Parts lists are subject to change based on availability or revised design criteria.

FOR FOUNDATION INFORMATION, PLEASE SEE PAGES 93-97.
FOR GENERAL INSTALLATION INFORMATION, PLEASE SEE PAGES 147-153.



STANDARD DESIGN - 45GSR
90MPH REV. G

45GSR
SOLID ROD

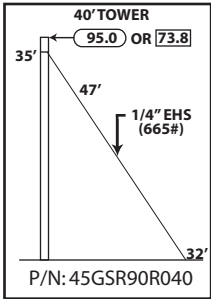

TOWER PARTS INCLUDED	45GSR20	45GSRSB	GA45GD	FDNS		TBSAFETY
				BASE	ANCHOR	
	2	1	1	FB1G	AB2	
GUYS & CONNECTIONS INCLUDED	1/4EHS	BG2144	3/8THH	1/2TBE&J		3
	150'	6	6	3		3
ANCHORS & GROUNDING INCLUDED	GAC3455TOP	AGK1GGX	BGK3GGX	CPC.5/.75		
	3	1	3	3		

40' ROHN 45GSR
All parts shown in table are included when ordering
Part No: 45GSR90R040

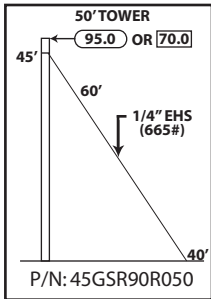

TOWER PARTS INCLUDED	45GSR20	45GSR10	45GSRSB	GA45GD	FDNS		TBSAFETY
					BASE	ANCHOR	
	2	1	1	1	FB1G	AB2	
GUYS & CONNECTIONS INCLUDED	1/4EHS	BG2144	3/8THH	1/2TBE&J		3	
	200'	6	6	3		3	
ANCHORS & GROUNDING INCLUDED	GAC3455TOP	AGK1GGX	BGK3GGX	CPC.5/.75			
	3	1	3	3			

50' ROHN 45GSR
All parts shown in table are included when ordering
Part No: 45GSR90R050

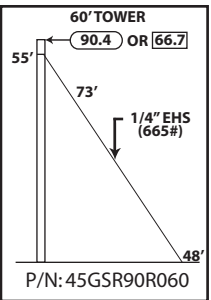

TOWER PARTS INCLUDED	45GSR20	45GSRSB	GA45GD	FDNS		TBSAFETY	
				BASE	ANCHOR		
	3	1	1	FB1G	AB2		
GUYS & CONNECTIONS INCLUDED	1/4EHS	BG2144	3/8THH	1/2TBE&J		3	
	250'	6	6	3		3	
ANCHORS & GROUNDING INCLUDED	GAC3455TOP	AGK1GGX	BGK3GGX	CPC.5/.75			
	3	1	3	3			

60' ROHN 45GSR
All parts shown in table are included when ordering
Part No: 45GSR90R060

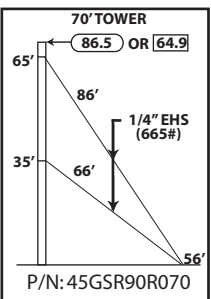

TOWER PARTS INCLUDED	45GSR20	45GSR10	45GSRSB	GA45GD	FDNS		TBSAFETY
					BASE	ANCHOR	
	3	1	1	2	FB1G	AB2	
GUYS & CONNECTIONS INCLUDED	1/4EHS	BG2144	3/8THH	1/2TBE&J		6	
	500'	12	12	6		3	
ANCHORS & GROUNDING INCLUDED	GAC3455TOP	AGK1GGX	BGK3GGX	CPC.5/.75			
	3	1	3	3			

70' ROHN 45GSR
All parts shown in table are included when ordering
Part No: 45GSR90R070

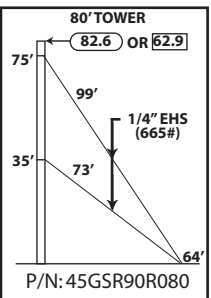

TOWER PARTS INCLUDED	45GSR20	45GSRSB	GA45GD	FDNS		TBSAFETY	
				BASE	ANCHOR		
	4	1	2	FB1G	AB2		
GUYS & CONNECTIONS INCLUDED	1/4EHS	BG2144	3/8THH	1/2TBE&J		6	
	550'	12	12	6		3	
ANCHORS & GROUNDING INCLUDED	GAC3455TOP	AGK1GGX	BGK3GGX	CPC.5/.75			
	3	1	3	3			

80' ROHN 45GSR
All parts shown in table are included when ordering
Part No: 45GSR90R080





**STANDARD DESIGN - 45GSR
90MPH REV. G**

45GSR
SOLID ROD

90' ROHN 45GSR
All parts shown in table
are included when ordering
Part No: 45GSR90R090

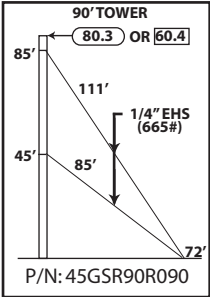

TOWER PARTS INCLUDED	45GSR20	45GSR10	45GSRSB	GA45GD	FDNS	
	4	1	1	2	BASE FB1G	ANCHOR AB2
GUYS & CONNECTIONS INCLUDED	1/4EHS	BG2144	3/8THH	1/2TBE&J	TBSAFETY	
	625'	12	12	6	3	
ANCHORS & GROUNDING INCLUDED	GAC3455TOP	AGK1GGX	BGK3GGX	CPC.5/.75		
	3	1	3	3		

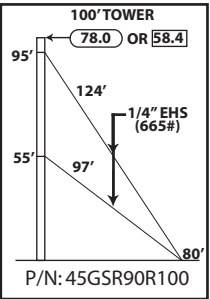

TOWER PARTS INCLUDED	45GSR20	45GSR10	45GSRSB	GA45GD	FDNS	
	5	1	1	2	BASE FB1G	ANCHOR AB2
GUYS & CONNECTIONS INCLUDED	1/4EHS	BG2144	3/8THH	1/2TBE&J	TBSAFETY	
	725'	12	12	6	3	
ANCHORS & GROUNDING INCLUDED	GAC3455TOP	AGK1GGX	BGK3GGX	CPC.5/.75		
	3	1	3	3		

100' ROHN 45GSR
All parts shown in table
are included when ordering
Part No: 45GSR90R100

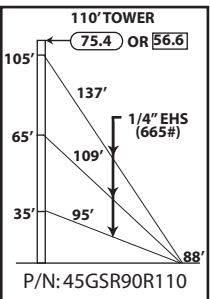

TOWER PARTS INCLUDED	45GSR20	45GSR10	45GSRSB	GA45GD	FDNS	
	5	1	1	3	BASE FB1G	ANCHOR AB2
GUYS & CONNECTIONS INCLUDED	1/4EHS	BG2144	3/8THH	1/2TBE&J	TBSAFETY	
	1100'	18	18	9	3	
ANCHORS & GROUNDING INCLUDED	GAC3455TOP	AGK1GGX	BGK3GGX	CPC.5/.75		
	3	1	3	3		

110' ROHN 45GSR
All parts shown in table
are included when ordering
Part No: 45GSR90R110

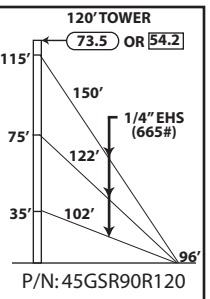

TOWER PARTS INCLUDED	45GSR20	45GSR10	45GSRSB	GA45GD	FDNS	
	6	1	1	3	BASE FB1G	ANCHOR AB2
GUYS & CONNECTIONS INCLUDED	1/4EHS	BG2144	3/8THH	1/2TBE&J	TBSAFETY	
	1200'	18	18	9	3	
ANCHORS & GROUNDING INCLUDED	GAC3455TOP	AGK1GGX	BGK3GGX	CPC.5/.75		
	3	1	3	3		

120' ROHN 45GSR
All parts shown in table
are included when ordering
Part No: 45GSR90R120

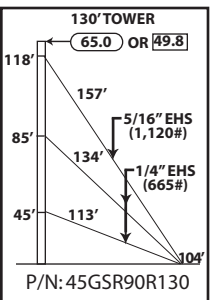

TOWER PARTS INCLUDED	45GSR20	45GSR10	45GSRSB	GA45GD	FDNS	
	6	1	1	3	BASE FB1G	ANCHOR AB2
GUYS & CONNECTIONS INCLUDED	1/4EHS	142265	BG2144	BG2146		
	800'	500'	12	6		
	3/8THH	7/16THH	5/8TBE&J	1/2TBE&J		
	12	6	3	6		
ANCHORS & GROUNDING INCLUDED	GAC3455TOP	AGK1GGX	BGK3GGX	CPC.5/.75	TBSAFETY	
	3	1	3	3	3	

130' ROHN 45GSR
All parts shown in table
are included when ordering
Part No: 45GSR90R130



STANDARD DESIGN - 45GSR
90MPH REV. G

45GSR
SOLID ROD

140' ROHN 45GSR
All parts shown in table are included when ordering
Part No: 45GSR90R140

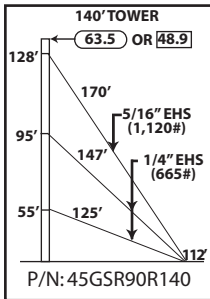

TOWER PARTS INCLUDED	45GSR20	45GSRSB	GA45GD	FDNS	
				BASE	ANCHOR
	7	1	3	FB1G	AB2
GUYS & CONNECTIONS INCLUDED	1/4EHS	142265	BG2144	BG2146	
	875'	550'	12	6	
	3/8THH	7/16THH	5/8TBE&J	1/2TBE&J	
	12	6	3	6	
ANCHORS & GROUNDING INCLUDED	GAC3455TOP	AGK1GGX	BGK3GGX	CPC.5/.75	TBSAFETY
	3	1	3	3	3

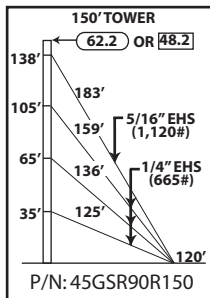

TOWER PARTS INCLUDED	45GSR20	45GSR10	45GSRSB	GA45GD	FDNS	
					BASE	ANCHOR
	7	1	1	4	FB1G	AB2
GUYS & CONNECTIONS INCLUDED	1/4EHS	142265	BG2144	BG2146		
	1350'	600'	18	6		
	3/8THH	7/16THH	5/8TBE&J	1/2TBE&J		
	18	6	3	9		
ANCHORS & GROUNDING INCLUDED	GAC3455TOP	AGK1GGX	BGK3GGX	CPC.5/.75	TBSAFETY	
	3	1	3	3	3	

150' ROHN 45GSR
All parts shown in table are included when ordering
Part No: 45GSR90R150

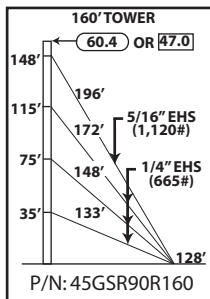

TOWER PARTS INCLUDED	45GSR20	45GSRSB	GA45GD	FDNS	
				BASE	ANCHOR
	8	1	4	FB1G	AB2
GUYS & CONNECTIONS INCLUDED	1/4EHS	142265	BG2144	BG2146	
	1450'	625'	18	6	
	3/8THH	7/16THH	5/8TBE&J	1/2TBE&J	
	18	6	3	9	
ANCHORS & GROUNDING INCLUDED	GAC3455TOP	AGK1GGX	BGK3GGX	CPC.5/.75	TBSAFETY
	3	1	3	3	3

160' ROHN 45GSR
All parts shown in table are included when ordering
Part No: 45GSR90R160

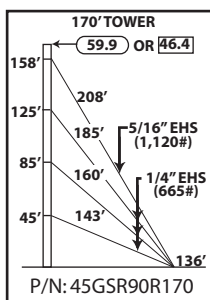

TOWER PARTS INCLUDED	45GSR20	45GSR10	45GSRSB	GA45GD	FDNS	
					BASE	ANCHOR
	8	1	1	4	FB1G	AB3
GUYS & CONNECTIONS INCLUDED	1/4EHS	142265	BG2144	BG2146		
	1575'	675'	18	6		
	3/8THH	7/16THH	5/8TBE&J	TBSAFETY		
	18	6	12	3		
ANCHORS & GROUNDING INCLUDED	GAC5655TOP	AGK1GGX	BGK3GGX	CPC1/1.25		
	3	1	3	3		

170' ROHN 45GSR
All parts shown in table are included when ordering
Part No: 45GSR90R170



**STANDARD DESIGN - 45GSR
90MPH REV. G**

45GSR
SOLID ROD

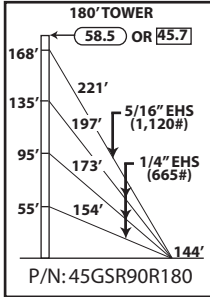

TOWER PARTS INCLUDED	45GSR20	45GSRSB	GA45GD	FDNS	
				BASE	ANCHOR
	9	1	4	FB1G	AB3
GUYS & CONNECTIONS INCLUDED	1/4EHS	142265	BG2144	BG2146	
	1675'	725'	18	6	
	3/8THH	7/16THH	5/8TBE&J	TBSAFETY	
	18	6	12	3	
ANCHORS & GROUNDING INCLUDED	GAC5655TOP	AGK1GGX	BGK3GGX	CPC1/1.25	
	3	1	3	3	

180' ROHN 45GSR
All parts shown in table are included when ordering
Part No: 45GSR90R180

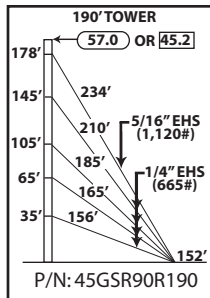

TOWER PARTS INCLUDED	45GSR20	45GSR10	45GSRSB	GA45GD	FDNS	
					BASE	ANCHOR
	9	1	1	5	FB1G	AB3
GUYS & CONNECTIONS INCLUDED	1/4EHS	142265	BG2144	BG2146		
	2300'	750'	24	6		
	3/8THH	7/16THH	5/8TBE&J	TBSAFETY		
	24	6	15	3		
ANCHORS & GROUNDING INCLUDED	GAC5655TOP	AGK1GGX	BGK3GGX	CPC1/1.25		
	3	1	3	3		

190' ROHN 45GSR
All parts shown in table are included when ordering
Part No: 45GSR90R190

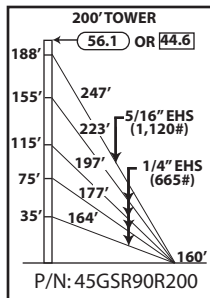

TOWER PARTS INCLUDED	45GSR20	45GSRSB	GA45GD	APL4A	FDNS	
					BASE	ANCHOR
	10	1	5	1	FB1G	AB3
GUYS & CONNECTIONS INCLUDED	1/4EHS	142265	BG2144	BG2146		
	2425'	800'	24	6		
	3/8THH	7/16THH	5/8TBE&J	TBSAFETY		
	24	6	15	3		
ANCHORS & GROUNDING INCLUDED	GAC5655TOP	AGK1GGX	BGK3GGX	CPC1/1.25		
	3	1	3	3		

200' ROHN 45GSR
All parts shown in table are included when ordering
Part No: 45GSR90R200

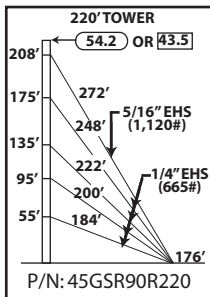

TOWER PARTS INCLUDED	45GSR20	45GSRSB	GA45GD	APL4A	FDNS	
					BASE	ANCHOR
	11	1	5	1	FB1G	AB3
GUYS & CONNECTIONS INCLUDED	1/4EHS	142265	BG2144	BG2146		
	2725'	875'	24	6		
	3/8THH	7/16THH	5/8TBE&J	TBSAFETY		
	24	6	15	3		
ANCHORS & GROUNDING INCLUDED	GAC5655TOP	AGK1GGX	BGK3GGX	CPC1/1.25		
	3	1	3	3		

220' ROHN 45GSR
All parts shown in table are included when ordering
Part No: 45GSR90R220



STANDARD DESIGN - 45GSR
90MPH REV. G

45GSR
SOLID ROD

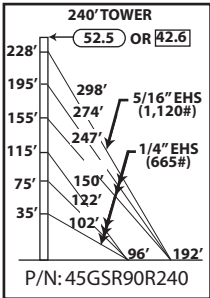

TOWER PARTS INCLUDED	45GSR20	45GSRSB	GA45GD	APL4A	BASE	INNER ANCHOR	OUTER ANCHOR
		12	1	6	1	FB1G	AB2
GUYS & CONNECTIONS INCLUDED	1/4EHS	142265	BG2144	BG2146			
	2850'	950'	30	6			
	3/8THH	7/16THH	5/8TBE&J	1/2TBE&J			
	30	6	3	15			
ANCHORS & GROUNDING INCLUDED	GAC3455TOP	AGK1GGX	BGK3GGX	CPC.5/.75	TBSAFETY		
	6	2	3	6	6		

240' ROHN 45GSR
All parts shown in table are included when ordering
Part No: 45GSR90R240

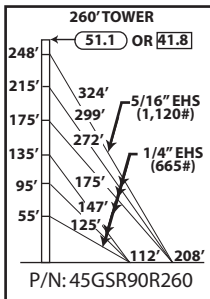

TOWER PARTS INCLUDED	45GSR20	45GSRSB	GA45GD	APL4A	BASE	INNER ANCHOR	OUTER ANCHOR
		13	1	6	1	FB1G	AB2
GUYS & CONNECTIONS INCLUDED	1/4EHS	142265	BG2144	BG2146			
	3250'	1050'	30	6			
	3/8THH	7/16THH	5/8TBE&J	1/2TBE&J			
	30	6	3	15			
ANCHORS & GROUNDING INCLUDED	GAC3455TOP	AGK1GGX	BGK3GGX	CPC.5/.75	TBSAFETY		
	6	2	3	6	6		

260' ROHN 45GSR
All parts shown in table are included when ordering
Part No: 45GSR90R260

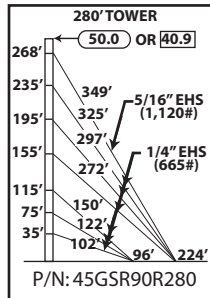

TOWER PARTS INCLUDED	45GSR20	45GSRSB	GA45GD	APL4A	BASE	INNER ANCHOR	OUTER ANCHOR
		14	1	7	1	FB1G	AB2
GUYS & CONNECTIONS INCLUDED	1/4EHS	142265	BG2144	BG2146	3/8THH		
	4050'	1125'	36	6	36		
	7/16THH	5/8TBE&J	1/2TBE&J	CPC.5/.75	CPC1/1.25		
	6	12	9	3	3		
ANCHORS & GROUNDING INCLUDED	GAC3455TOP	GAC5655TOP	AGK1GGX	BGK3GGX	TBSAFETY		
	3	3	2	3	6		

280' ROHN 45GSR
All parts shown in table are included when ordering
Part No: 45GSR90R280

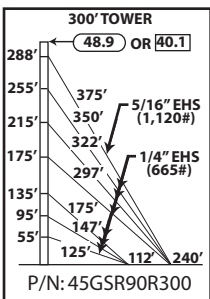

TOWER PARTS INCLUDED	45GSR20	45GSRSB	GA45GD	APL4A	BASE	INNER ANCHOR	OUTER ANCHOR
		15	1	7	1	FB1G	AB2
GUYS & CONNECTIONS INCLUDED	1/4EHS	142265	BG2144	BG2146	3/8THH		
	4525'	1200'	36	6	36		
	7/16THH	5/8TBE&J	1/2TBE&J	CPC.5/.75	CPC1/1.25		
	6	12	9	3	3		
ANCHORS & GROUNDING INCLUDED	GAC3455TOP	GAC5655TOP	AGK1GGX	BGK3GGX	TBSAFETY		
	3	3	2	3	6		

300' ROHN 45GSR
All parts shown in table are included when ordering
Part No: 45GSR90R300



**STANDARD DESIGN - 45GSR
90MPH REV. G**

45GSR
SOLID ROD

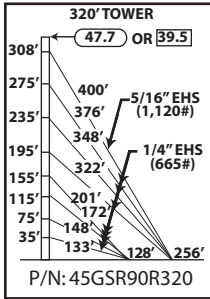

TOWER PARTS INCLUDED	45GSR20	45GSR5B	GA45GD	APL4A	BASE	INNER ANCHOR	OUTER ANCHOR
	16	1	8	1	FB1G	AB2	AB3
GUYS & CONNECTIONS INCLUDED	1/4EHS	142265	BG2144	BG2146	3/8THH		
	5450'	1275'	42	6	42		
	7/16THH	5/8TBE&J	1/2TBE&J	CPC.5/.75	CPC1/1.25		
	6	12	12	3	3		
ANCHORS & GROUNDING INCLUDED	GAC3455TOP	GAC5655TOP	AGK1GGX	BGK3GGX	TBSAFETY		
	3	3	2	3	6		

320' ROHN 45GSR

All parts shown in table are included when ordering
Part No: 45GSR90R320

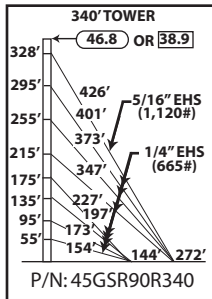

TOWER PARTS INCLUDED	45GSR20	45GSR5B	GA45GD	APL4A	BASE	INNER ANCHOR	OUTER ANCHOR
	17	1	8	1	FB1G	AB2	AB3
GUYS & CONNECTIONS INCLUDED	1/4EHS	142265	BG2144	BG2146	3/8THH		
	5975'	1375'	42	6	42		
	7/16THH	5/8TBE&J	1/2TBE&J	CPC.5/.75	CPC1/1.25		
	6	12	12	3	3		
ANCHORS & GROUNDING INCLUDED	GAC3455TOP	GAC5655TOP	AGK1GGX	BGK3GGX	TBSAFETY		
	3	3	2	3	6		

340' ROHN 45GSR

All parts shown in table are included when ordering
Part No: 45GSR90R340



STANDARD DESIGN - 45GSR
110MPH REV. G

45GSR
SOLID ROD

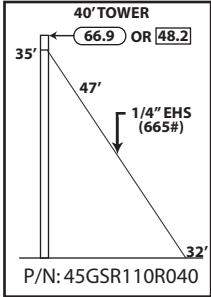

TOWER PARTS INCLUDED	45GSR20	45GSRSB	GA45GD	FDNS	
	2	1	1	BASE	ANCHOR
GUYS & CONNECTIONS INCLUDED	1/4EHS	BG2144	3/8THH	1/2TBE&J	TBSAFETY
	150'	6	6	3	3
ANCHORS & GROUNDING INCLUDED	GAC3455TOP	AGK1GGX	BGK3GGX	CPC.5/.75	
	3	1	3	3	

40' ROHN 45GSR
All parts shown in table are included when ordering
Part No: 45GSR110R040

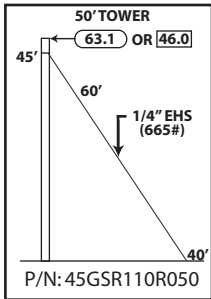

TOWER PARTS INCLUDED	45GSR20	45GSR10	45GSRSB	GA45GD	FDNS	
	2	1	1	1	BASE	ANCHOR
GUYS & CONNECTIONS INCLUDED	1/4EHS	BG2144	3/8THH	1/2TBE&J	TBSAFETY	
	200'	6	6	3	3	
ANCHORS & GROUNDING INCLUDED	GAC3455TOP	AGK1GGX	BGK3GGX	CPC.5/.75		
	3	1	3	3		

50' ROHN 45GSR
All parts shown in table are included when ordering
Part No: 45GSR110R050

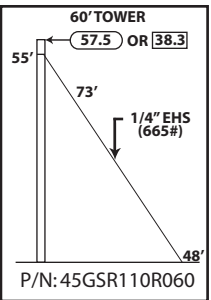

TOWER PARTS INCLUDED	45GSR20	45GSRSB	GA45GD	FDNS	
	3	1	1	BASE	ANCHOR
GUYS & CONNECTIONS INCLUDED	1/4EHS	BG2144	3/8THH	1/2TBE&J	TBSAFETY
	250'	6	6	3	3
ANCHORS & GROUNDING INCLUDED	GAC3455TOP	AGK1GGX	BGK3GGX	CPC.5/.75	
	3	1	3	3	

60' ROHN 45GSR
All parts shown in table are included when ordering
Part No: 45GSR110R060

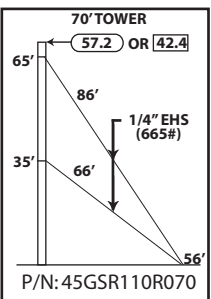

TOWER PARTS INCLUDED	45GSR20	45GSR10	45GSRSB	GA45GD	FDNS	
	3	1	1	2	BASE	ANCHOR
GUYS & CONNECTIONS INCLUDED	1/4EHS	BG2144	3/8THH	1/2TBE&J	TBSAFETY	
	500'	12	12	6	3	
ANCHORS & GROUNDING INCLUDED	GAC3455TOP	AGK1GGX	BGK3GGX	CPC.5/.75		
	3	1	3	3		

70' ROHN 45GSR
All parts shown in table are included when ordering
Part No: 45GSR110R070

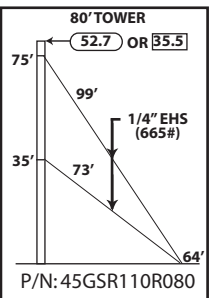

TOWER PARTS INCLUDED	45GSR20	45GSRSB	GA45GD	FDNS	
	4	1	2	BASE	ANCHOR
GUYS & CONNECTIONS INCLUDED	1/4EHS	BG2144	3/8THH	1/2TBE&J	TBSAFETY
	550'	12	12	6	3
ANCHORS & GROUNDING INCLUDED	GAC3455TOP	AGK1GGX	BGK3GGX	CPC.5/.75	
	3	1	3	3	

80' ROHN 45GSR
All parts shown in table are included when ordering
Part No: 45GSR110R080





**STANDARD DESIGN - 45GSR
110MPH REV. G**

45GSR
SOLID ROD

90' ROHN 45GSR
All parts shown in table
are included when ordering
Part No: 45GSR110R090

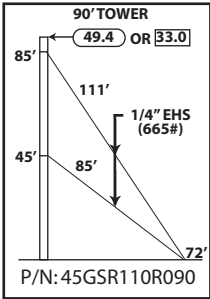

TOWER PARTS INCLUDED	45GSR20	45GSR10	45GSRSB	GA45GD	FDNS	
					BASE	ANCHOR
TOWER PARTS INCLUDED	4	1	1	2	FB2G	AB2
GUYS & CONNECTIONS INCLUDED	1/4EHS	BG2144	3/8THH	1/2TBE&J	TBSAFETY	
	625'	12	12	6	3	
ANCHORS & GROUNDING INCLUDED	GAC3455TOP	AGK1GGX	BGK3GGX	CPC.5/.75		
	3	1	3	3		

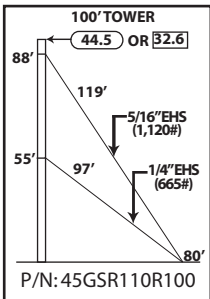

TOWER PARTS INCLUDED	45GSR20	45GSRSB	GA45GD	FDNS	
				BASE	ANCHOR
TOWER PARTS INCLUDED	5	1	2	FB2G	AB2
GUYS & CONNECTIONS INCLUDED	1/4EHS	142265	3/8THH	1/2TBE&J	5/8TBE&J
	325'	400'	6	3	3
	7/16THH	BG2144	BG2146	TBSAFETY	
	6	6	6	3	
ANCHORS & GROUNDING INCLUDED	GAC3455TOP	AGK1GGX	BGK3GGX	CPC.5/.75	
	3	1	3	3	

100' ROHN 45GSR
All parts shown in table
are included when ordering
Part No: 45GSR110R100

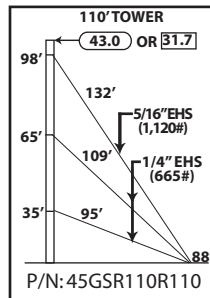

TOWER PARTS INCLUDED	45GSR20	45GSR10	45GSRSB	GA45GD	FDNS	
					BASE	ANCHOR
TOWER PARTS INCLUDED	5	1	1	3	FB2G	AB2
GUY WIRE & CONNECTION INCLUDED	1/4EHS	142265	3/8THH	1/2TBE&J	5/8TBE&J	
	650'	425'	12	6	3	
	7/16THH	BG2144	BG2146	TBSAFETY		
	6	12	6	3		
ANCHORS & GROUNDING INCLUDED	GAC3455TOP	AGK1GGX	BGK3GGX	CPC.5/.75		
	3	1	3	3		

110' ROHN 45GSR
All parts shown in table
are included when ordering
Part No: 45GSR110R110

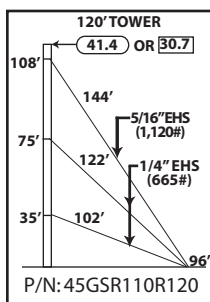

TOWER PARTS INCLUDED	45GSR20	45GSRSB	GA45GD	FDNS	
				BASE	ANCHOR
TOWER PARTS INCLUDED	6	1	3	FB2G	AB2
GUYS & CONNECTIONS INCLUDED	1/4EHS	142265	3/8THH	1/2TBE&J	5/8TBE&J
	725'	475'	12	6	3
	7/16THH	BG2144	BG2146	TBSAFETY	
	6	12	6	3	
ANCHORS & GROUNDING INCLUDED	GAC3455TOP	AGK1GGX	BGK3GGX	CPC.5/.75	
	3	1	3	3	

120' ROHN 45GSR
All parts shown in table
are included when ordering
Part No: 45GSR110R120



STANDARD DESIGN - 45GSR
110MPH REV. G

45GSR
SOLID ROD

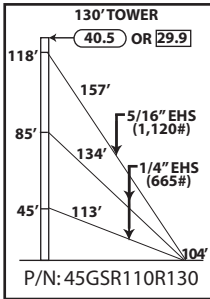

TOWER PARTS INCLUDED	45GSR20	45GSR10	45GSRSB	GA45GD	FDNS	
					BASE	ANCHOR
	6	1	1	3	FB2G	AB2
GUYS & CONNECTIONS INCLUDED	1/4EHS	142265	3/8THH	1/2TBE&J	5/8TBE&J	
	800'	500'	12	6	3	
	7/16THH	BG2144	BG2146	TBSAFETY		
	6	12	6	3		
ANCHORS & GROUNDING INCLUDED	GAC3455TOP	AGK1GGX	BGK3GGX	CPC.5/.75		
	3	1	3	3		

130' ROHN 45GSR
All parts shown in table are included when ordering
Part No: 45GSR110R130

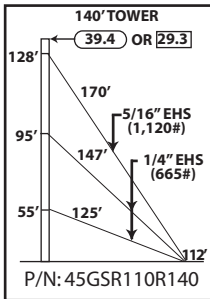

TOWER PARTS INCLUDED	45GSR20	45GSRSB	GA45GD	FDNS		
				BASE	ANCHOR	
	7	1	3	FB2G	AB2	
GUYS & CONNECTIONS INCLUDED	1/4EHS	142265	3/8THH	1/2TBE&J	5/8TBE&J	
	875'	550'	12	6	3	
	7/16THH	BG2144	BG2146	TBSAFETY		
	6	12	6	3		
ANCHORS & GROUNDING INCLUDED	GAC3455TOP	AGK1GGX	BGK3GGX	CPC.5/.75		
	3	1	3	3		

140' ROHN 45GSR
All parts shown in table are included when ordering
Part No: 45GSR110R140

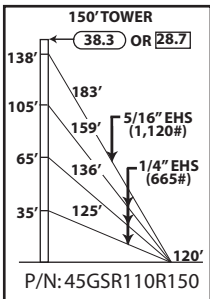

TOWER PARTS INCLUDED	45GSR20	45GSR10	45GSRSB	GA45GD	FDNS	
					BASE	ANCHOR
	7	1	1	4	FB2G	AB3
GUYS & CONNECTIONS INCLUDED	1/4EHS	142265	3/8THH	5/8TBE&J		
	1350'	600'	18	12		
	7/16THH	BG2144	BG2146	TBSAFETY		
	6	18	6	3		
ANCHORS & GROUNDING INCLUDED	GAC5655TOP	AGK1GGX	BGK3GGX	CPC1/1.25		
	3	1	3	3		

150' ROHN 45GSR
All parts shown in table are included when ordering
Part No: 45GSR110R150

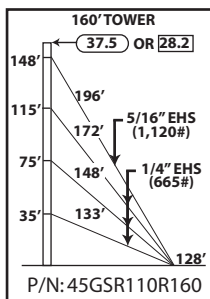

TOWER PARTS INCLUDED	45GSR20	45GSRSB	GA45GD	FDNS	
				BASE	ANCHOR
	8	1	4	FB2G	AB3
GUYS & CONNECTIONS INCLUDED	1/4EHS	142265	3/8THH	5/8TBE&J	
	1450'	625'	18	12	
	7/16THH	BG2144	BG2146	TBSAFETY	
	6	18	6	3	
ANCHORS & GROUNDING INCLUDED	GAC5655TOP	AGK1GGX	BGK3GGX	CPC1/1.25	
	3	1	3	3	

160' ROHN 45GSR
All parts shown in table are included when ordering
Part No: 45GSR110R160





**STANDARD DESIGN - 45GSR
110MPH REV. G**

45GSR
SOLID ROD

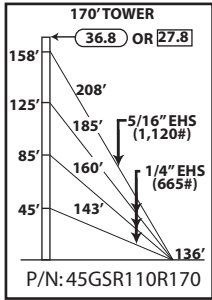

TOWER PARTS INCLUDED	45GSR20	45GSR10	45GSRSB	GA45GD	FDNS	
					BASE	ANCHOR
	8	1	1	4	FB2G	AB3
GUYS & CONNECTIONS INCLUDED	1/4EHS	142265	3/8THH	5/8TB&J		
	1575'	675'	18	12		
	7/16THH	BG2144	BG2146	TBSAFETY		
	6	18	6	3		
ANCHORS & GROUNDING INCLUDED	GAC5655TOP	AGK1GGX	BGK3GGX	CPC1/1.25		
	3	1	3	3		

170' ROHN 45GSR
All parts shown in table are included when ordering
Part No: 45GSR110R170

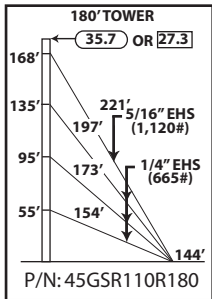

TOWER PARTS INCLUDED	45GSR20	45GSRSB	GA45GD	FDNS		
				BASE	ANCHOR	
	9	1	4	FB2G	AB3	
GUYS & CONNECTIONS INCLUDED	1/4EHS	142265	3/8THH	5/8TB&J		
	1675'	725'	18	12		
	7/16THH	BG2144	BG2146	TBSAFETY		
	6	18	6	3		
ANCHORS & GROUNDING INCLUDED	GAC5655TOP	AGK1GGX	BGK3GGX	CPC1/1.25		
	3	1	3	3		

180' ROHN 45GSR
All parts shown in table are included when ordering
Part No: 45GSR110R180

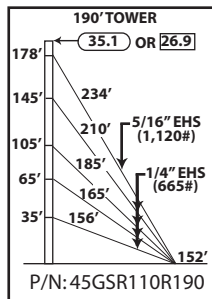

TOWER PARTS INCLUDED	45GSR20	45GSR10	45GSRSB	GA45GD	FDNS	
					BASE	ANCHOR
	9	1	1	5	FB2G	AB3
GUYS & CONNECTIONS INCLUDED	1/4EHS	142265	3/8THH	5/8TB&J		
	2300'	750'	24	15		
	7/16THH	BG2144	BG2146	TBSAFETY		
	6	24	6	3		
ANCHORS & GROUNDING INCLUDED	GAC5655TOP	AGK1GGX	BGK3GGX	CPC1/1.25		
	3	1	3	3		

190' ROHN 45GSR
All parts shown in table are included when ordering
Part No: 45GSR110R190

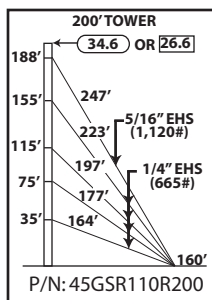

TOWER PARTS INCLUDED	45GSR20	45GSRSB	GA45GD	APL4A	FDNS	
					BASE	ANCHOR
	10	1	5	1	FB2G	AB4
GUYS & CONNECTIONS INCLUDED	1/4EHS	142265	3/8THH	5/8TB&J		
	2425'	800'	24	15		
	7/16THH	BG2144	BG2146	TBSAFETY		
	6	24	6	3		
ANCHORS & GROUNDING INCLUDED	GAC5655TOP	AGK1GGX	BGK3GGX	CPC1/1.25		
	3	1	3	3		

200' ROHN 45GSR
All parts shown in table are included when ordering
Part No: 45GSR110R200



STANDARD DESIGN - 45GSR
110MPH REV. G

45GSR
SOLID ROD

220' ROHN 45GSR
All parts shown in table are included when ordering
Part No: 45GSR110R220

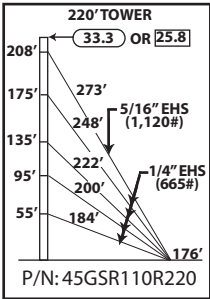

TOWER PARTS INCLUDED	45GSR20	45GSRSB	GA45GD	APL4A	FDNS	
	11	1	5	1	BASE	ANCHOR
GUYS & CONNECTIONS INCLUDED	1/4EHS	142265	3/8THH	5/8TBE&J		
	2725'	875'	24	15		
	7/16THH	BG2144	BG2146	TBSAFETY		
	6	24	6	3		
ANCHORS & GROUNDING INCLUDED	GAC5655TOP	AGK1GGX	BGK3GGX	CPC1/1.25		
	3	1	3	3		

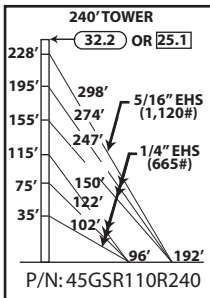

TOWER PARTS INCLUDED	45GSR20	45GSRSB	GA45GD	APL4A	BASE	INNER ANCHOR	OUTER ANCHOR
	12	1	6	1	FB2G	AB2	AB3
GUYS & CONNECTIONS INCLUDED	1/4EHS	142265	BG2144	BG2146	3/8THH		
	2850'	950'	30	6	30		
	7/16THH	5/8TBE&J	1/2TBE&J	CPC.5/.75	CPC1/1.25		
	6	9	9	3	3		
ANCHORS & GROUNDING INCLUDED	GAC3455TOP	GAC5655TOP	AGK1GGX	BGK3GGX	TBSAFETY		
	3	3	2	3	6		

240' ROHN 45GSR
All parts shown in table are included when ordering
Part No: 45GSR110R240

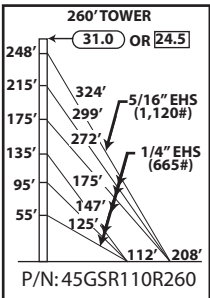

TOWER PARTS INCLUDED	45GSR20	45GSRSB	GA45GD	APL4A	BASE	INNER ANCHOR	OUTER ANCHOR
	13	1	6	1	FB2G	AB2	AB3
GUYS & CONNECTIONS INCLUDED	1/4EHS	142265	BG2144	BG2146	3/8THH		
	3250'	1050'	30	6	30		
	7/16THH	5/8TBE&J	1/2TBE&J	CPC.5/.75	CPC1/1.25		
	6	9	9	3	3		
ANCHORS & GROUNDING INCLUDED	GAC3455TOP	GAC5655TOP	AGK1GGX	BGK3GGX	TBSAFETY		
	3	3	2	3	6		

260' ROHN 45GSR
All parts shown in table are included when ordering
Part No: 45GSR110R260

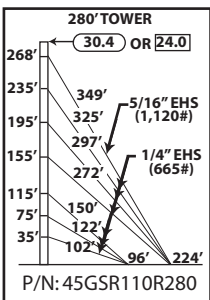

TOWER PARTS INCLUDED	45GSR20	45GSRSB	GA45GD	APL4A	BASE	INNER ANCHOR	OUTER ANCHOR
	14	1	7	1	FB2G	AB2	AB4
GUYS & CONNECTIONS INCLUDED	1/4EHS	142265	BG2144	BG2146	3/8THH		
	4050'	1125'	36	6	36		
	7/16THH	5/8TBE&J	1/2TBE&J	CPC.5/.75	CPC1/1.25		
	6	12	9	3	3		
ANCHORS & GROUNDING INCLUDED	GAC3455TOP	GAC5655TOP	AGK1GGX	BGK3GGX	TBSAFETY		
	3	3	2	3	6		

280' ROHN 45GSR
All parts shown in table are included when ordering
Part No: 45GSR110R280





**STANDARD DESIGN - 45GSR
110MPH REV. G**

45GSR
SOLID ROD

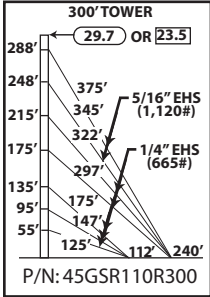

TOWER PARTS INCLUDED	45GSR20	45GSRSB	GA45GD	APL4A	BASE	INNER ANCHOR	OUTER ANCHOR
		15	1	7	1	FB2G	AB2
GUYS & CONNECTIONS INCLUDED	1/4EHS	142265	BG2144	BG2146	3/8THH		
	3400'	2300'	30	12	30		
	7/16THH	5/8TBE&J	1/2TBE&J	CPC.5/1.75	CPC1/1.25		
	12	12	9	3	3		
ANCHORS & GROUNDING INCLUDED	GAC3455TOP	GAC5655TOP	AGK1GGX	BGK3GGX	TBSAFETY		
	3	3	2	3	6		

300' ROHN 45GSR
All parts shown in table are included when ordering
Part No: 45GSR110R300

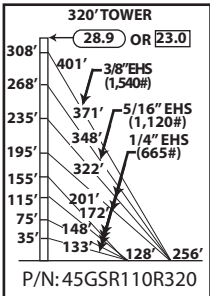

TOWER PARTS INCLUDED	45GSR20	45GSRSB	GA45GD	APL4A	BASE	INNER ANCHOR	OUTER ANCHOR
		15	1	7	1	FB2G	AB3
GUYS & CONNECTIONS INCLUDED	1/4EHS	142265	142261	BG2144	BG2146	BG2147	5/8S
	4225'	1200'	1300'	36	6	6	3
	1/2THH	3/8THH	7/16THH	5/8TBE&J	5/8S	45GSR20L82*	
	6	36	6	24	3	1	
ANCHORS & GROUNDING INCLUDED	GAC5655TOP	AGK1GGX	BGK3GGX	CPC1/1.25	TBSAFETY		
	6	2	3	6	6		

320' ROHN 45GSR
All parts shown in table are included when ordering
Part No: 45GSR110R320

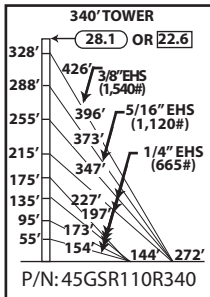

TOWER PARTS INCLUDED	45GSR20	45GSRSB	GA45GD	APL4A	BASE	INNER ANCHOR	OUTER ANCHOR
		16	1	7	1	FB2G	AB3
GUYS & CONNECTIONS INCLUDED	1/4EHS	142265	142261	BG2144	BG2146	BG2147	5/8S
	4700'	1275'	1375'	36	6	6	3
	1/2THH	3/8THH	7/16THH	5/8TBE&J	5/8S	45GSR20L82*	
	6	36	6	24	3	1	
ANCHORS & GROUNDING INCLUDED	GAC5655TOP	AGK1GGX	BGK3GGX	CPC1/1.25	TBSAFETY		
	6	2	3	6	6		

340' ROHN 45GSR
All parts shown in table are included when ordering
Part No: 45GSR110R340

* Guy lug sections required for 3/8" guys.



STANDARD DESIGN - 45GSR
130MPH REV. G

45GSR
SOLID ROD

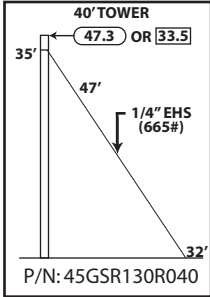

TOWER PARTS INCLUDED	45GSR20	45GSRSB	GA45GD	FDNS	
	2	1	1	BASE	ANCHOR
GUYS & CONNECTIONS INCLUDED	1/4EHS	BG2144	3/8THH	1/2TBE&J	TBSAFETY
	150'	6	6	3	3
ANCHORS & GROUNDING INCLUDED	GAC3455TOP	AGK1GGX	BGK3GGX	CPC.5/.75	
	3	1	3	3	

40' ROHN 45GSR
All parts shown in table are included when ordering
Part No: 45GSR130R040

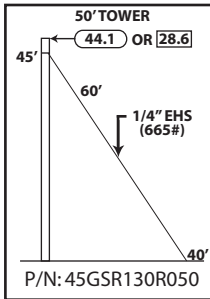

TOWER PARTS INCLUDED	45GSR20	45GSR10	45GSRSB	GA45GD	FDNS	
	2	1	1	1	BASE	ANCHOR
GUYS & CONNECTIONS INCLUDED	1/4EHS	BG2144	3/8THH	1/2TBE&J	TBSAFETY	
	200'	6	6	3	3	
ANCHORS & GROUNDING INCLUDED	GAC3455TOP	AGK1GGX	BGK3GGX	CPC.5/.75		
	3	1	3	3		

50' ROHN 45GSR
All parts shown in table are included when ordering
Part No: 45GSR90R050

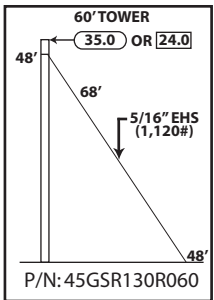

TOWER PARTS INCLUDED	45GSR20	45GSRSB	GA45GD	FDNS	
	3	1	1	BASE	ANCHOR
GUYS & CONNECTIONS INCLUDED	142265	BG2146	7/16THH	5/8TBE&J	TBSAFETY
	225'	6	6	3	3
ANCHORS & GROUNDING INCLUDED	GAC3455TOP	AGK1GGX	BGK3GGX	CPC.5/.75	
	3	1	3	3	

60' ROHN 45GSR
All parts shown in table are included when ordering
Part No: 45GSR90R060

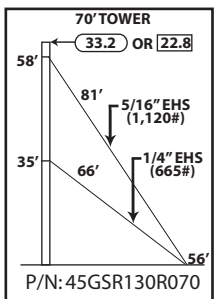

TOWER PARTS INCLUDED	45GSR20	45GSR10	45GSRSB	GA45GD	FDNS	
	3	1	1	2	BASE	ANCHOR
GUYS & CONNECTIONS INCLUDED	1/4EHS	142265	BG2144	BG2146	3/8THH	
	225'	275'	6	6	6	
	7/16THH	1/2TBE&J	5/8TBE&J	TBSAFETY		
	6	3	3	3		
ANCHORS & GROUNDING INCLUDED	GAC3455TOP	AGK1GGX	BGK3GGX	CPC.5/.75		
	3	1	3	3		

70' ROHN 45GSR
All parts shown in table are included when ordering
Part No: 45GSR130R070





**STANDARD DESIGN - 45GSR
130MPH REV. G**

45GSR
SOLID ROD

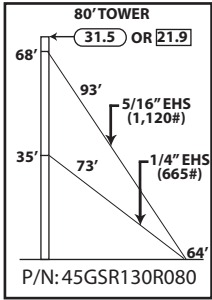

TOWER PARTS INCLUDED	45GSR20	45GSRSB	GA45GD	FDNS	
				BASE	ANCHOR
	4	1	2	FB2G	AB2
GUYS & CONNECTIONS INCLUDED	1/4EHS	142265	BG2144	BG2146	3/8THH
	250'	300'	6	6	6
	7/16THH	1/2TBE&J	5/8TBE&J	TBSAFETY	
	6	3	3	3	
ANCHORS & GROUNDING INCLUDED	GAC3455TOP	AGK1GGX	BGK3GGX	CPC.5/.75	
	3	1	3	3	

80' ROHN 45GSR
All parts shown in table are included when ordering
Part No: 45GSR130R080

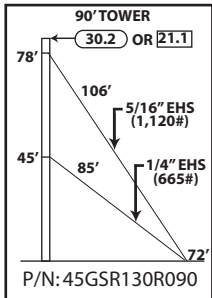

TOWER PARTS INCLUDED	45GSR20	45GSR10	45GSRSB	GA45GD	FDNS	
					BASE	ANCHOR
	4	1	1	2	FB2G	AB2
GUYS & CONNECTIONS INCLUDED	1/4EHS	142265	BG2144	BG2146	3/8THH	
	275'	350'	6	6	6	
	7/16THH	1/2TBE&J	5/8TBE&J	TBSAFETY		
	6	3	3	3		
ANCHORS & GROUNDING INCLUDED	GAC3455TOP	AGK1GGX	BGK3GGX	CPC.5/.75		
	3	1	3	3		

90' ROHN 45GSR
All parts shown in table are included when ordering
Part No: 45GSR130R090

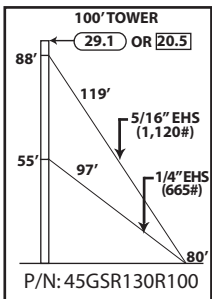

TOWER PARTS INCLUDED	45GSR20	45GSRSB	GA45GD	FDNS	
				BASE	ANCHOR
	5	1	2	FB2G	AB2
GUYS & CONNECTIONS INCLUDED	1/4EHS	142265	BG2144	BG2146	3/8THH
	325'	400'	6	6	6
	7/16THH	1/2TBE&J	5/8TBE&J	TBSAFETY	
	6	3	3	3	
ANCHORS & GROUNDING INCLUDED	GAC3455TOP	AGK1GGX	BGK3GGX	CPC.5/.75	
	3	1	3	3	

100' ROHN 45GSR
All parts shown in table are included when ordering
Part No: 45GSR130R100

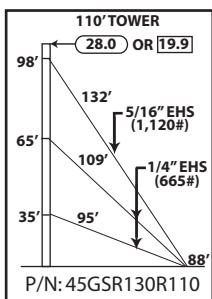

TOWER PARTS INCLUDED	45GSR20	45GSR10	45GSRSB	GA45GD	FDNS	
					BASE	ANCHOR
	5	1	1	3	FB2G	AB3
GUYS & CONNECTIONS INCLUDED	1/4EHS	142265	BG2144	BG2146		
	650'	425'	12	6		
	3/8THH	7/16THH	5/8TBE&J	TBSAFETY		
	12	6	9	3		
ANCHORS & GROUNDING INCLUDED	GAC5655TOP	AGK1GGX	BGK3GGX	CPC1/1.25		
	3	1	3	3		

110' ROHN 45GSR
All parts shown in table are included when ordering
Part No: 45GSR130R110



STANDARD DESIGN - 45GSR
130MPH REV. G

45GSR
SOLID ROD

120' ROHN 45GSR
All parts shown in table are included when ordering
Part No: 45GSR130R120

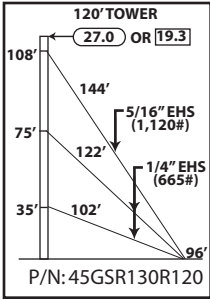

TOWER PARTS INCLUDED	45GSR20	45GSRSB	GA45GD	FDNS	
				BASE	ANCHOR
	6	1	3	FB2G	AB3
GUYS & CONNECTIONS INCLUDED	1/4EHS	142265	BG2144	BG2146	
	725'	475'	12	6	
	3/8THH	7/16THH	5/8TBE&J	TBSAFETY	
	12	6	9	3	
ANCHORS & GROUNDING INCLUDED	GAC5655TOP	AGK1GGX	BGK3GGX	CPC1/1.25	
	3	1	3	3	

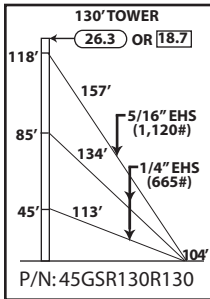

TOWER PARTS INCLUDED	45GSR20	45GSR10	45GSRSB	GA45GD	FDNS	
					BASE	ANCHOR
	6	1	1	3	FB2G	AB3
GUYS & CONNECTIONS INCLUDED	1/4EHS	142265	BG2144	BG2146		
	800'	500'	12	6		
	3/8THH	7/16THH	5/8TBE&J	TBSAFETY		
	12	6	9	3		
ANCHORS & GROUNDING INCLUDED	GAC5655TOP	AGK1GGX	BGK3GGX	CPC1/1.25		
	3	1	3	3		

130' ROHN 45GSR
All parts shown in table are included when ordering
Part No: 45GSR130R130

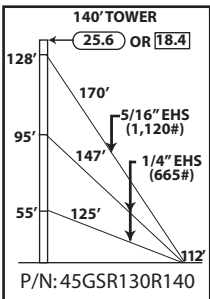

TOWER PARTS INCLUDED	45GSR20	45GSRSB	GA45GD	FDNS	
				BASE	ANCHOR
	7	1	3	FB2G	AB3
GUYS & CONNECTIONS INCLUDED	1/4EHS	142265	BG2144	BG2146	
	875'	550'	12	6	
	3/8THH	7/16THH	5/8TBE&J	TBSAFETY	
	12	6	9	3	
ANCHORS & GROUNDING INCLUDED	GAC5655TOP	AGK1GGX	BGK3GGX	CPC1/1.25	
	3	1	3	3	

140' ROHN 45GSR
All parts shown in table are included when ordering
Part No: 45GSR130R140

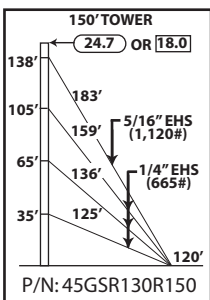

TOWER PARTS INCLUDED	45GSR20	45GSR10	45GSRSB	GA45GD	FDNS	
					BASE	ANCHOR
	7	1	1	4	FB2G	AB4
GUYS & CONNECTIONS INCLUDED	1/4EHS	142265	BG2144	BG2146		
	1350'	600'	18	6		
	3/8THH	7/16THH	3/4TBE&J	TBSAFETY		
	18	6	12	3		
ANCHORS & GROUNDING INCLUDED	GAC5755TOP	AGK1GGX	BGK3GGX	CPC1.5/2		
	3	1	3	3		

150' ROHN 45GSR
All parts shown in table are included when ordering
Part No: 45GSR130R150



**STANDARD DESIGN - 45GSR
130MPH REV. G**

45GSR
SOLID ROD

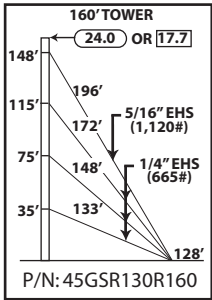

TOWER PARTS INCLUDED	45GSR20	45GSRSB	GA45GD	FDNS	
				BASE	ANCHOR
	8	1	4	FB2G	AB4
GUYS & CONNECTIONS INCLUDED	1/4EHS	142265	BG2144	BG2146	
	1450'	625'	18	6	
	3/8THH	7/16THH	3/4TBE&J	TBSAFETY	
	18	6	12	3	
ANCHORS & GROUNDING INCLUDED	GAC5755TOP	AGK1GGX	BGK3GGX	CPC1.5/2	
	3	1	3	3	

160' ROHN 45GSR
All parts shown in table are included when ordering
Part No: 45GSR130R160

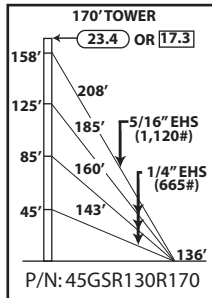

TOWER PARTS INCLUDED	45GSR20	45GSR10	45GSRSB	GA45GD	FDNS	
					BASE	ANCHOR
	8	1	1	4	FB2G	AB4
GUYS & CONNECTIONS INCLUDED	1/4EHS	142265	BG2144	BG2146		
	1575'	675'	18	6		
	3/8THH	7/16THH	3/4TBE&J	TBSAFETY		
	18	6	12	3		
ANCHORS & GROUNDING INCLUDED	GAC5755TOP	AGK1GGX	BGK3GGX	CPC1.5/2		
	3	1	3	3		

170' ROHN 45GSR
All parts shown in table are included when ordering
Part No: 45GSR130R170

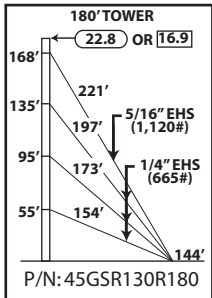

TOWER PARTS INCLUDED	45GSR20	45GSRSB	GA45GD	FDNS	
				BASE	ANCHOR
	9	1	4	FB2G	AB4
GUYS & CONNECTIONS INCLUDED	1/4EHS	142265	BG2144	BG2146	
	1675'	725'	18	6	
	3/8THH	7/16THH	3/4TBE&J	TBSAFETY	
	18	6	12	3	
ANCHORS & GROUNDING INCLUDED	GAC5755TOP	AGK1GGX	BGK3GGX	CPC1.5/2	
	3	1	3	3	

180' ROHN 45GSR
All parts shown in table are included when ordering
Part No: 45GSR130R180

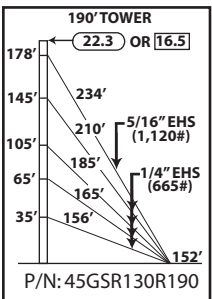

TOWER PARTS INCLUDED	45GSR20	45GSR10	45GSRSB	GA45GD	FDNS	
					BASE	ANCHOR
	9	1	1	5	FB2G	AB4
GUYS & CONNECTIONS INCLUDED	1/4EHS	142265	BG2144	BG2146		
	2300'	750'	24	6		
	3/8THH	7/16THH	3/4TBE&J	TBSAFETY		
	24	6	15	3		
ANCHORS & GROUNDING INCLUDED	GAC5755TOP	AGK1GGX	BGK3GGX	CPC1.5/2		
	3	1	3	3		

190' ROHN 45GSR
All parts shown in table are included when ordering
Part No: 45GSR130R190



STANDARD DESIGN - 45GSR
130MPH REV. G

45GSR
SOLID ROD

200' ROHN 45GSR
All parts shown in table
are included when ordering
Part No: 45GSR130R200

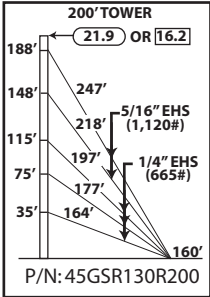

TOWER PARTS INCLUDED	45GSR20	45GSRSB	GA45GD	APL4A	FDNS	
	10	1	5	1	BASE	ANCHOR
GUYS & CONNECTIONS INCLUDED	1/4EHS	142265	BG2144	BG2146		
	1725'	1500'	18	12		
	3/8THH	7/16THH	3/4TBE&J	TBSAFETY		
	18	12	15	3		
ANCHORS & GROUNDING INCLUDED	GAC5755TOP	AGK1GGX	BGK3GGX	CPC1.5/2		
	3	1	3	3		

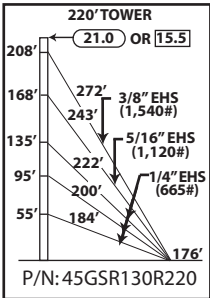

TOWER PARTS INCLUDED	45GSR20	45GSRSB	GA45GD	APL4A	FDNS	
	10	1	4	1	BASE	ANCHOR
GUYS & CONNECTIONS INCLUDED	1/4EHS	142265	142261	BG2144	45GSR20L82*	
	1950'	775'	875'	18	1	
	BG2146	BG2147	7/16THH	1/2THH		
	6	6	6	6		
	3/8THH	5/8S	3/4TBE&J	TBSAFETY		
	18	3	15	3		
ANCHORS & GROUNDING INCLUDED	GAC5755TOP	AGK1GGX	BGK3GGX	CPC1.5/2		
	3	1	3	3		

220' ROHN 45GSR
All parts shown in table
are included when ordering
Part No: 45GSR130R220

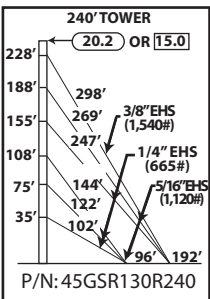

TOWER PARTS INCLUDED	45GSR20	45GSRSB	GA45GD	APL4A	BASE	INNER ANCHOR	OUTER ANCHOR
	11	1	5	1	FB2G	AB3	AB4
GUYS & CONNECTIONS INCLUDED	1/4EHS	142265	142261	BG2144	45GSR20L82*		
	1500'	1325'	950'	18	1		
	BG2146	BG2147	7/16THH	1/2THH			
	12	6	12	6			
	3/8THH	5/8S	5/8TBE&J	TBSAFETY			
	18	3	18	6			
ANCHORS & GROUNDING INCLUDED	GAC5655TOP	AGK1GGX	BGK3GGX	CPC1/1.25			
	6	2	3	6			

240' ROHN 45GSR
All parts shown in table
are included when ordering
Part No: 45GSR130R240

* Guy lug section required for 3/8" guys.



**STANDARD DESIGN - 45GSR
130MPH REV. G**

45GSR
SOLID ROD

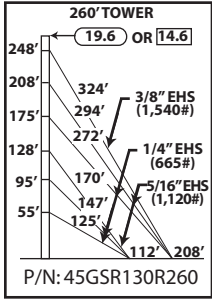

TOWER PARTS INCLUDED	45GSR20	45GSRSB	GA45GD	APL4A	BASE	INNER ANCHOR	OUTER ANCHOR
		12	1	5	1	FB2G	AB3
GUYS & CONNECTIONS INCLUDED	1/4EHS	142265	142261	BG2144	45GSR20L82*		
	1750'	1500'	1050'	18	1		
	BG2146	BG2147	7/16THH	1/2THH			
	12	6	12	6			
	3/8THH	5/8S	5/8TBE&J	TBSAFETY			
	18	3	18	6			
ANCHORS & GROUNDING INCLUDED	GAC5655TOP	AGK1GGX	BGK3GGX	CPC1/1.25			
	6	2	3	6			

260' ROHN 45GSR
All parts shown in table are included when ordering
Part No: 45GSR130R260

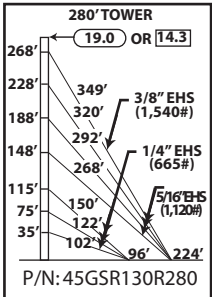

TOWER PARTS INCLUDED	45GSR20	45GSRSB	GA45GD	APL4A	BASE	INNER ANCHOR	OUTER ANCHOR
		13	1	6	1	FB2G	AB3
GUYS & CONNECTIONS INCLUDED	1/4EHS	142265	142261	BG2144	45GSR20L82*		
	1200'	2800'	1125'	18	1		
	BG2146	BG2147	7/16THH	1/2THH			
	18	6	18	6			
	3/8THH	5/8S	3/4TBE&J	TBSAFETY			
	18	3	21	6			
ANCHORS & GROUNDING INCLUDED	GAC5755TOP	AGK1GGX	BGK3GGX	CPC1.5/2			
	6	2	3	6			

280' ROHN 45GSR
All parts shown in table are included when ordering
Part No: 45GSR130R280

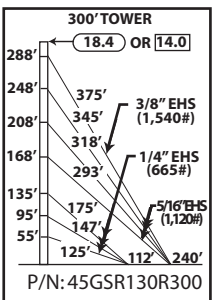

TOWER PARTS INCLUDED	45GSR20	45GSRSB	GA45GD	APL4A	BASE	INNER ANCHOR	OUTER ANCHOR
		14	1	6	1	FB3G	AB3
GUYS & CONNECTIONS INCLUDED	1/4EHS	142265	142261	BG2144	45GSR20L82*		
	1425'	3050'	1200'	18	1		
	BG2146	BG2147	7/16THH	1/2THH			
	18	6	18	6			
	3/8THH	5/8S	3/4TBE&J	TBSAFETY			
	18	3	21	6			
ANCHORS & GROUNDING INCLUDED	GAC5755TOP	AGK1GGX	BGK3GGX	CPC1.5/2			
	6	2	3	6			

300' ROHN 45GSR
All parts shown in table are included when ordering
Part No: 45GSR130R300

* Guy lug section required for 3/8" guys.



STANDARD DESIGN - 45GSR
130MPH REV. G

45GSR
SOLID ROD

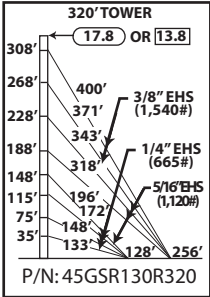

TOWER PARTS INCLUDED	45GSR20	45GSRSB	GA45GD	APL4A	BASE	INNER ANCHOR	OUTER ANCHOR
		14	1	6	1	FB3G	AB3
GUYS & CONNECTIONS INCLUDED	1/4EHS	142265	142261	BG2144	45GSR20.82*		
	1450'	2750'	2475'	18	2		
	BG2146	BG2147	7/16THH	1/2THH			
	18	12	18	12			
	3/8THH	5/8S	3/4TBE&J	TBSAFETY			
	18	6	24	6			
ANCHORS & GROUNDING INCLUDED	GAC5755TOP	AGK1GGX	BGK3GGX	CPC1.5/2			
	6	2	3	6			

320' ROHN 45GSR
All parts shown in table are included when ordering
Part No: 45GSR130R320

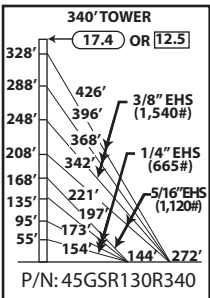

TOWER PARTS INCLUDED	45GSR20	45GSRSB	GA45GD	APL4A	BASE	INNER ANCHOR	OUTER ANCHOR
		14	1	5	1	FB3G	AB4
GUYS & CONNECTIONS INCLUDED	1/4EHS	142265	142261	BG2144	45GSR20.82*		
	1675'	1800'	3800'	18	3		
	BG2146	BG2147	7/16THH	1/2THH			
	12	18	12	18			
	3/8THH	5/8S	3/4TBE&J	TBSAFETY			
	18	9	24	6			
ANCHORS & GROUNDING INCLUDED	GAC5755TOP	AGK1GGX	BGK3GGX	CPC1.5/2			
	6	2	3	6			

340' ROHN 45GSR
All parts shown in table are included when ordering
Part No: 45GSR130R340

* Guy lug section required for 3/8" guys.

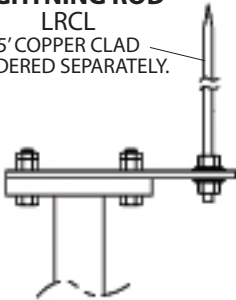
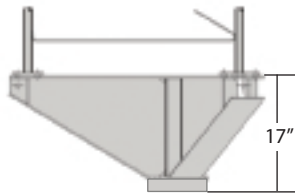
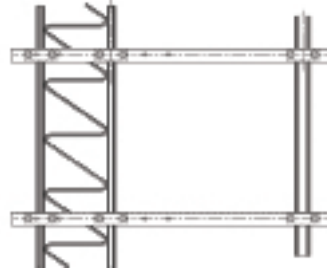
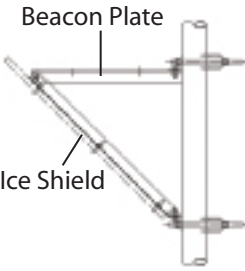
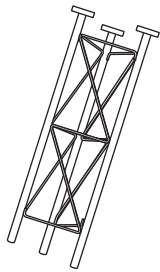

PARTS & ACCESSORIES

 <p>LEG MOUNTED BEACON PLATE KIT APL4A FOR MOUNTING BEACON OR LIGHTNING ROD. BOLTS TO TOP OF STANDARD SECTION. INCLUDES BEACON PLATE, (2) CAP PLATES, NUTS AND BOLTS.</p>	<p>LIGHTNING ROD LRCL 5' COPPER CLAD ORDERED SEPARATELY.</p>  <p>LIGHTNING ROD PLATE KIT VW132 INCLUDES: LIGHTNING ROD PLATE, NUTS AND BOLTS.</p>	 <p>TAPERED BASE 45GSRTBPP* FOR USE WITH PIER PIN (3/4X12PP) AND BEARING PLATE (BP6) SOLD SEPARATELY.</p>	 <p>3' SIDE ARM WITH (2) TIE BACKS KY1653A MOUNTING TUBE PROVIDED IS 3' LONG, 2 - 3/8" O.D.</p>
 <p>MID BEACON PLATE / ICE SHIELD APL1258UM</p>	 <p>4.3' SHORT BASE 45GSRSB FOR EMBEDMENT IN CONCRETE.</p>		

Refer to pages 63-65 for the following accessories that also fit the 45GSR tower:

- Pier Pin (3/4x12PP)
- Side Arm Bracket (SA253UA)
- Dish Mount (VY4311A2 & VY4311A)
- Face Mount (DM45G2 & DM454)
- Universal House Bracket (HBUTVRO)
- Torque Bar (TB45D)
- Guy Bracket (GA45GD)
- Anti-Climb Panels (VW913A)
- Work Platform (WP45G)
- Safety Ring (SR245)
- Climbing Harness (TTFBH-4D & TTFBH-C/P)
- Safety Cable Slider (TT-WG-500-W/SMC)
- Safety Cable System (See page 65 for P/N)

* TOWERS MOUNTED ON THESE BASES MUST BE BRACKETED OR GUYED AT ALL TIMES. TEMPORARY STEEL GUYING MAY ALSO BE NECESSARY DURING INSTALLATION AND DISMANTLING.



ANCHOR INFORMATION

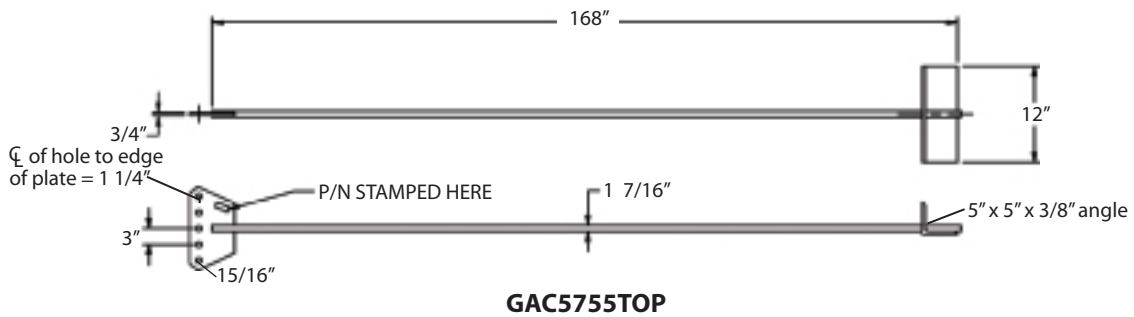
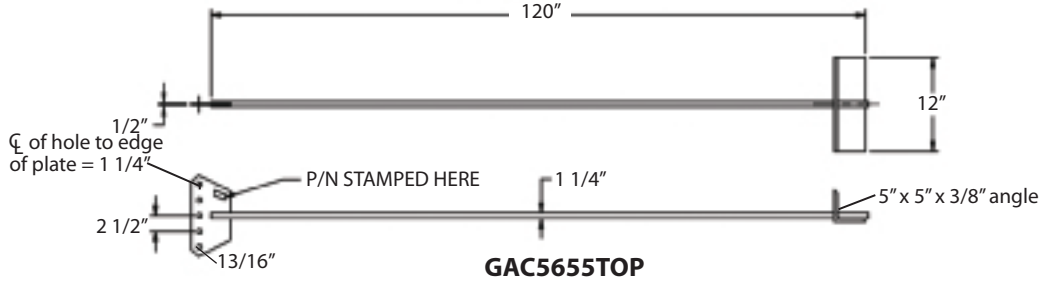
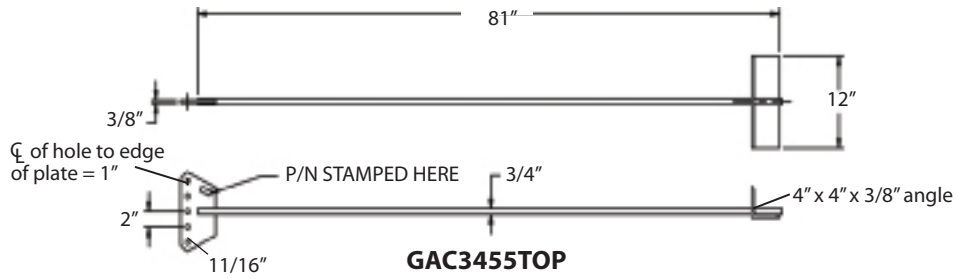

REV G
ANCHOR GROUNDING
AGK1GGX

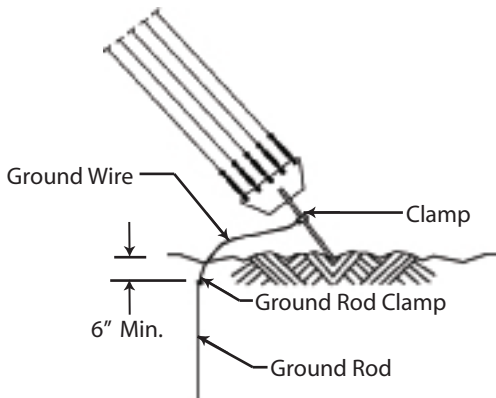

REV G
BASE GROUNDING
BGK3GGX

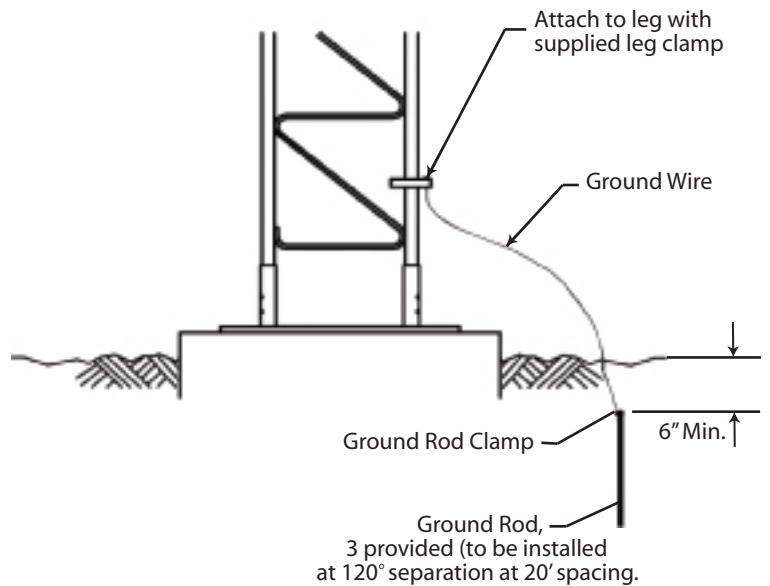



STANDARD ANCHOR BLOCKS

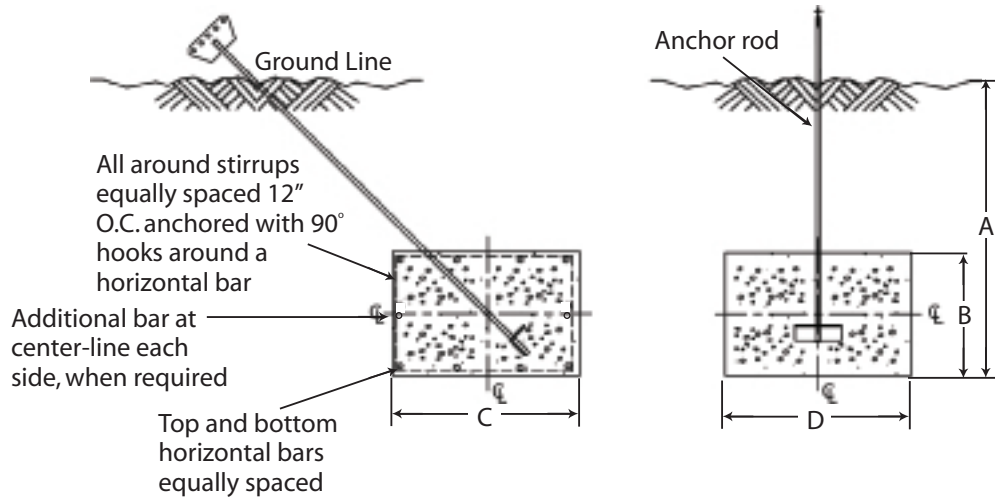

Refer to pages 95-96 for anchor rod installation angles.

Block	Anchor Dimensions (in.)				Horizontal Bars (Qty. & Size)	Stirrup Size & Spacing	Concrete Vol. (Cu. Yds.)
	A	B	C	D			
AB2	4' - 0"	1' - 6"	4' - 0"	6' - 0"	(5) #6 Bars, Top Layer (5) #6 Bars, Bottom Layer (0) Additional Bar, Each Side	#3 @ 12" O.C.	1.33 Per Block 4.0 Total for 3
AB3	6' - 0"	1' - 6"	3' - 0"	6' - 0"	(4) #6 Bars, Top Layer (4) #6 Bars, Bottom Layer (0) Additional Bar, Each Side	#3 @ 12" O.C.	1.0 Per Block 3.0 Total for 3
AB4	6' - 0"	1' - 6"	4' - 0"	9' - 0"	(5) #6 Bars, Top Layer (5) #6 Bars, Bottom Layer (0) Additional Bar, Each Side	#4 @ 12" O.C.	2.0 Per Block 6.0 Total for 3
AB5	8' - 0"	2' - 0"	3' - 0"	10' - 0"	(4) #7 Bars, Top Layer (4) #7 Bars, Bottom Layer (1) Additional Bar, Each Side	#4 @ 12" O.C.	2.22 Per Block 6.7 Total for 3
AB6	8' - 0"	2' - 0"	4' - 0"	10' - 0"	(5) #7 Bars, Top Layer (5) #7 Bars, Bottom Layer (1) Additional Bar, Each Side	#4 @ 12" O.C.	2.96 Per Block 8.9 Total for 3



ANCHOR ROD INSTALLATION ANGLES

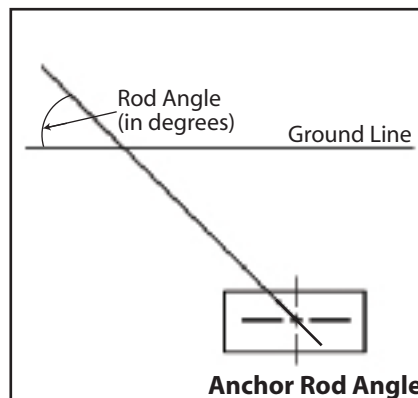
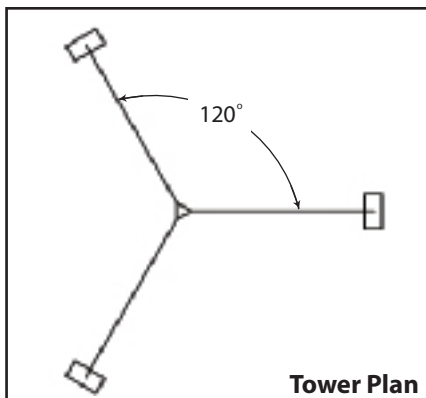

45GSR 90MPH				
Tower Height	Inner Rod Number	Inner Rod Angle	Outer Rod Number	Outer Rod Angle
40'	GAC3455TOP	48	-	-
50'	GAC3455TOP	49	-	-
60'	GAC3455TOP	49	-	-
70'	GAC3455TOP	44	-	-
80'	GAC3455TOP	43	-	-
90'	GAC3455TOP	44	-	-
100'	GAC3455TOP	44	-	-
110'	GAC3455TOP	42	-	-
120'	GAC3455TOP	42	-	-
130'	GAC3455TOP	42	-	-
140'	GAC3455TOP	42	-	-
150'	GAC3455TOP	40	-	-
160'	GAC3455TOP	40	-	-
170'	GAC5655TOP	40	-	-
180'	GAC5655TOP	41	-	-
190'	GAC5655TOP	40	-	-
200'	GAC5655TOP	40	-	-
220'	GAC5655TOP	40	-	-
240'	GAC3455TOP	38	GAC3455TOP	46
260'	GAC3455TOP	40	GAC3455TOP	46
280'	GAC3455TOP	38	GAC5655TOP	44
300'	GAC3455TOP	40	GAC5655TOP	44
320'	GAC3455TOP	37	GAC5655TOP	45
340'	GAC3455TOP	38	GAC5655TOP	45

45GSR 110MPH				
Tower Height	Inner Rod Number	Inner Rod Angle	Outer Rod Number	Outer Rod Angle
40'	GAC3455TOP	48	-	-
50'	GAC3455TOP	49	-	-
60'	GAC3455TOP	49	-	-
70'	GAC3455TOP	43	-	-
80'	GAC3455TOP	42	-	-
90'	GAC3455TOP	43	-	-
100'	GAC3455TOP	44	-	-
110'	GAC3455TOP	41	-	-
120'	GAC3455TOP	41	-	-
130'	GAC3455TOP	41	-	-
140'	GAC3455TOP	42	-	-
150'	GAC5655TOP	40	-	-
160'	GAC5655TOP	40	-	-
170'	GAC5655TOP	40	-	-
180'	GAC5655TOP	40	-	-
190'	GAC5655TOP	40	-	-
200'	GAC5655TOP	40	-	-
220'	GAC5655TOP	40	-	-
240'	GAC3455TOP	39	GAC5655TOP	45
260'	GAC3455TOP	40	GAC5655TOP	45
280'	GAC3455TOP	39	GAC5655TOP	43
300'	GAC3455TOP	40	GAC5655TOP	44
320'	GAC5655TOP	40	GAC5655TOP	44
340'	GAC5655TOP	40	GAC5655TOP	44

See the following page for 45GSR | 130mph anchor rod slopes.



ANCHOR ROD INSTALLATION ANGLES

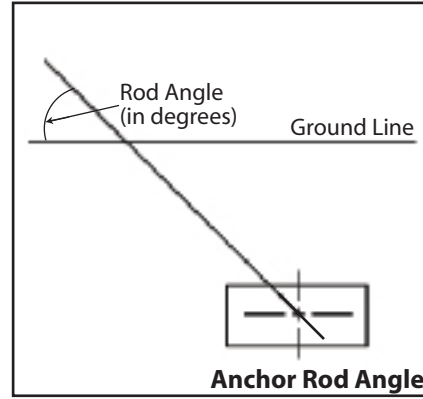
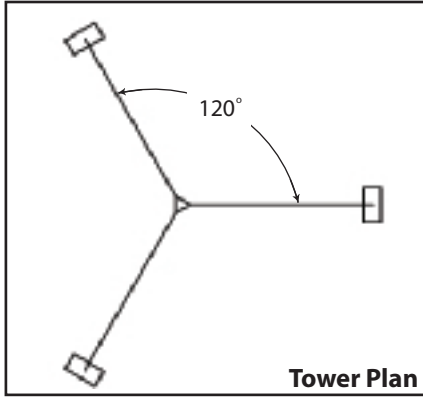

45GSR 130MPH				
Tower Height	Inner Rod Number	Inner Rod Angle	Outer Rod Number	Outer Rod Angle
40'	GAC3455TOP	48	-	-
50'	GAC3455TOP	48	-	-
60'	GAC3455TOP	45	-	-
70'	GAC3455TOP	42	-	-
80'	GAC3455TOP	42	-	-
90'	GAC3455TOP	43	-	-
100'	GAC3455TOP	43	-	-
110'	GAC5655TOP	40	-	-
120'	GAC5655TOP	40	-	-
130'	GAC5655TOP	41	-	-
140'	GAC5655TOP	41	-	-
150'	GAC5755TOP	39	-	-
160'	GAC5755TOP	38	-	-
170'	GAC5755TOP	39	-	-
180'	GAC5755TOP	39	-	-
190'	GAC5755TOP	37	-	-
200'	GAC5755TOP	38	-	-
220'	GAC5755TOP	38	-	-
240'	GAC5655TOP	40	GAC5655TOP	45
260'	GAC5655TOP	41	GAC5655TOP	45
280'	GAC5755TOP	38	GAC5755TOP	42
300'	GAC5755TOP	39	GAC5755TOP	43
320'	GAC5755TOP	37	GAC5655TOP	43
340'	GAC5755TOP	38	GAC5655TOP	43



STANDARD MAT FOUNDATION FOR 45GSR TOWERS

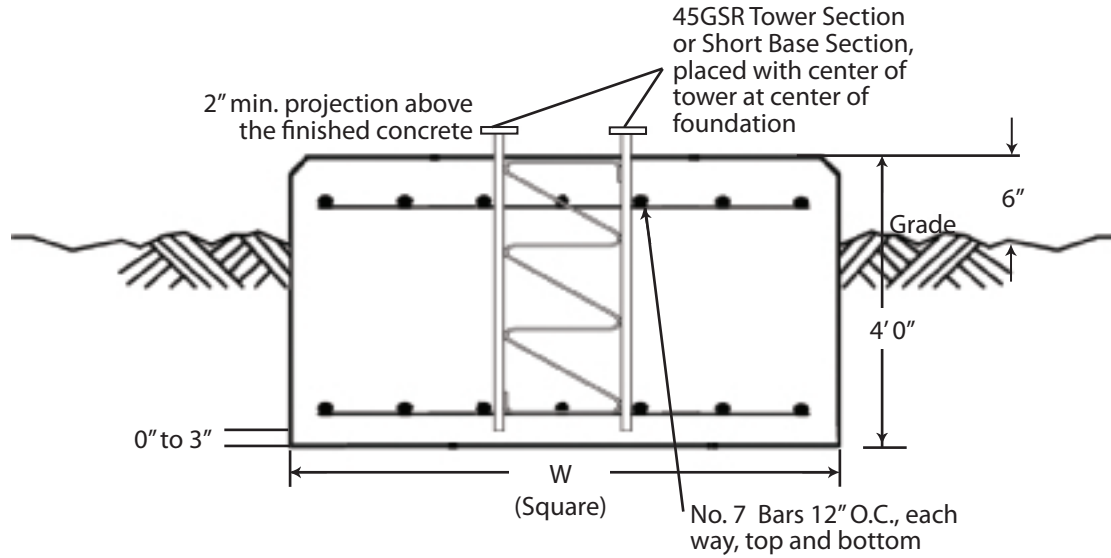

Base	Mat Width (W)	Concrete Vol. (Cu. Yds.)
FB1G	4' - 6"	3.0
FB2G	5' - 3"	4.1
FB3G	6' - 3"	5.8



STANDARD METEOROLOGICAL TOWERS

Complete Kit Includes:

- Assembly and foundation drawings
- All necessary tower sections
- Tower short base
- All guy wire and connectors
- All guy anchors
- Base and anchor grounding kits

60 m

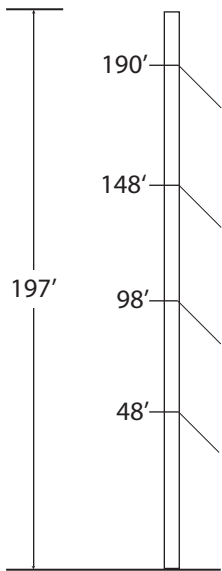
**60MMET**

- 4 Guy Elevations
- 1 Fixed Base Foundation
- 1 Anchor Radius

Boom Height	EPA / WT. (no ice)	EPA / WT. (3/4" radial ice)
40 m	9.00 sq. ft. / 200 lbs.	25.00 sq. ft. / 600 lbs.
50 m	9.00 sq. ft. / 200 lbs.	25.00 sq. ft. / 600 lbs.
60 m	9.00 sq. ft. / 200 lbs.	25.00 sq. ft. / 600 lbs.

ANSI/TIA-222-G
 110 MPH - 3 Second Gust (No Ice)
 50 MPH - 3 Second Gust (3/4" Radial Ice)
 Structure Class II
 Exposure Category C
 Topographic Category I

80 m

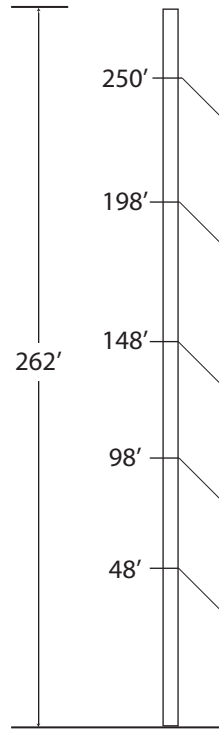
**80MMET**

- 5 Guy Elevations
- 1 Fixed Base Foundation
- 1 Anchor Radius

Boom Height	EPA / WT. (no ice)	EPA / WT. (3/4" radial ice)
60 m	9.00 sq. ft. / 200 lbs.	25.00 sq. ft. / 600 lbs.
70 m	9.00 sq. ft. / 200 lbs.	25.00 sq. ft. / 600 lbs.
80 m	9.00 sq. ft. / 200 lbs.	25.00 sq. ft. / 600 lbs.

ANSI/TIA-222-G
 110 MPH - 3 Second Gust (No Ice)
 50 MPH - 3 Second Gust (3/4" Radial Ice)
 Structure Class II
 Exposure Category C
 Topographic Category I

100 m

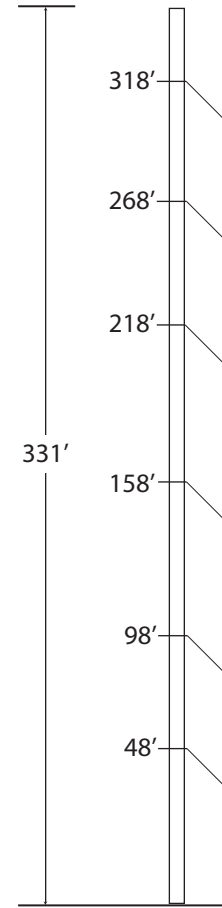
**100MMET**

- 6 Guy Elevations
- 1 Fixed Base Foundation
- 2 Anchor Radii

Boom Height	EPA / WT. (no ice)	EPA / WT. (3/4" radial ice)
50 m	9.00 sq. ft. / 200 lbs.	25.00 sq. ft. / 600 lbs.
75 m	9.00 sq. ft. / 200 lbs.	25.00 sq. ft. / 600 lbs.
100 m	9.00 sq. ft. / 200 lbs.	25.00 sq. ft. / 600 lbs.

ANSI/TIA-222-G
 110 MPH - 3 Second Gust (No Ice)
 50 MPH - 3 Second Gust (3/4" Radial Ice)
 Structure Class II
 Exposure Category C
 Topographic Category I

Tower design assumes (1) elevator track over height of structure.



STANDARD 45GSR METEOROLOGICAL TOWER

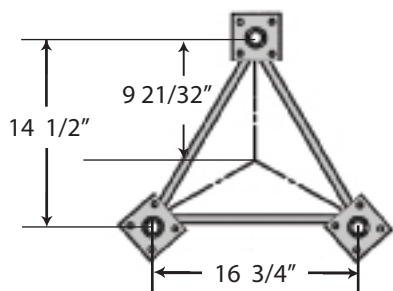

Tower Height (m)	Guy Radius (ft.) 120° separation	Base Foundation No.	Anchor Foundation No.
60	156	FB2G	AB4
80	210	FB3G	AB5
100	106 / 264	FB3G	AB2 / AB6

Refer to page 288 for anchor rod details.

FOR FOUNDATION INFORMATION, PLEASE SEE PAGES 94 & 97. FOR GENERAL INSTALLATION INFORMATION, PLEASE SEE PAGES 147-153.

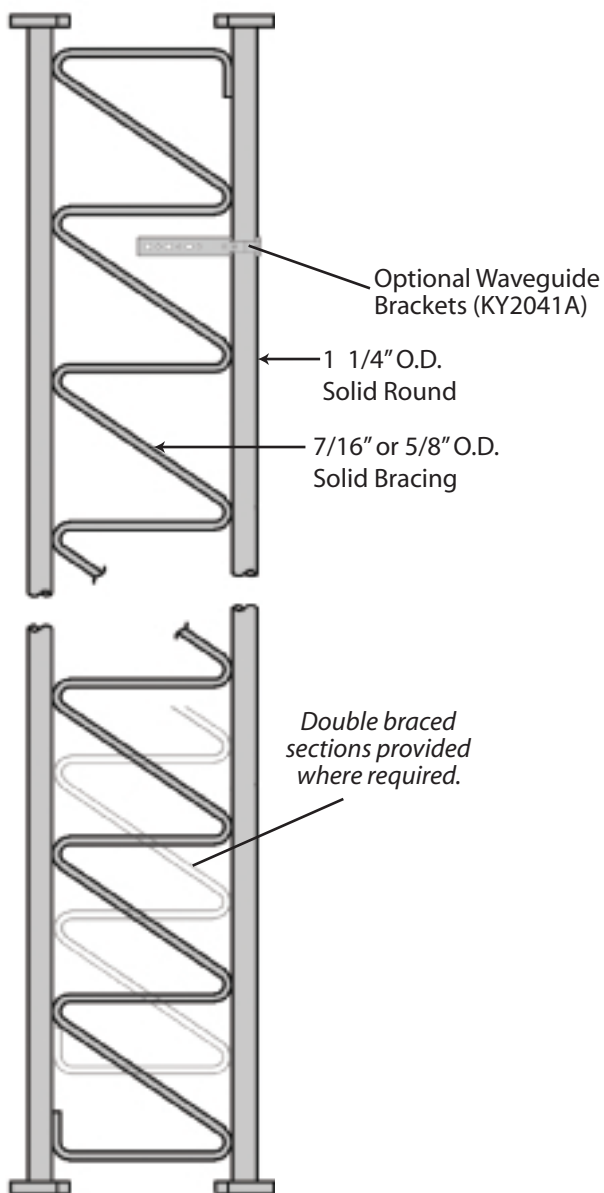

STANDARD SECTION
45GSR10 - 10' Section
45GSR20 - 20' Section

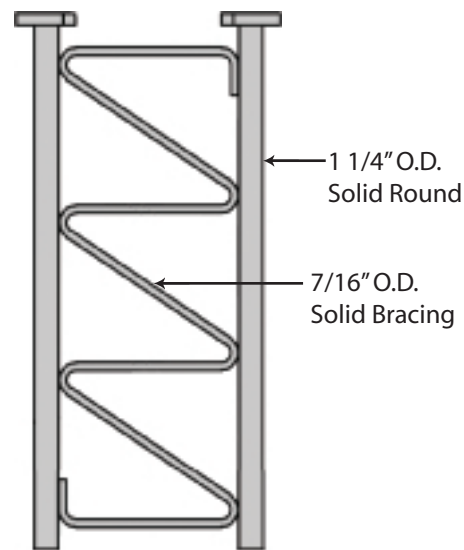

4.3' 45GSR SHORT BASE
45GSRSB

TO BE EMBEDDED IN CONCRETE.



STANDARD 55G GUYED TOWER

ROHN 55G
The first. The original.



55G

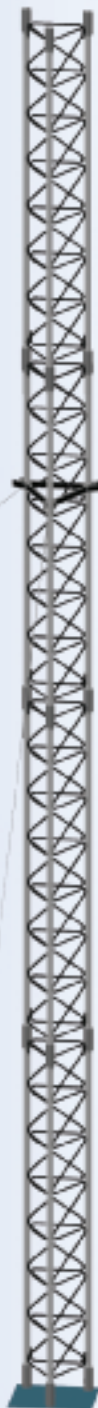

GENERAL USE

The 55G lends itself to a wide variety of uses, particularly where unusual wind loading and height requirements exist. The 55G was designed to provide excellent strength in heights up to 400'.

FEATURES

- Completely hot-dip galvanized after fabrication
- Built on a 17" equilateral triangle design
- High strength tubular legs joined by Zig-Zag® cross members
- Each section contains all required nuts and bolts shipped with section
- Continuous solid round steel bracing

CAUTION

Mixing copies of ROHN towers with ROHN towers is dangerous and voids all engineering and warranty data supplied by ROHN. Materials used by others are not the same quality and have not been tested or engineered by ROHN. Mixing ROHN tower sections with non-ROHN products may cause tower failure or injury.

Per Rev G requirements, any structure greater than 10' requires a climber safety device. Please see page 116 for ordering information.



STANDARD 55G GUYED TOWER SECTIONS

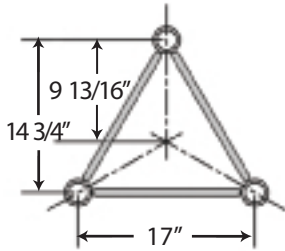

QUICK REFERENCE	
PARTS & ACCESSORIES	PAGES 115-116
GROUNDING INFORMATION	PAGE 117
FOUNDATION INFORMATION	PAGES 117-120

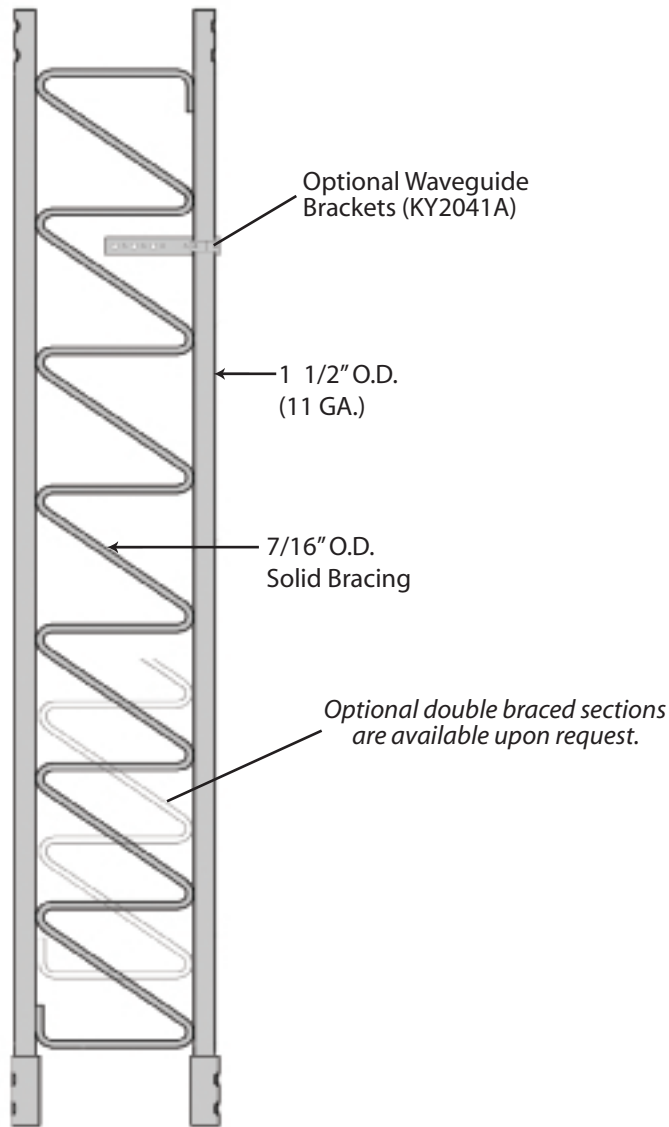

STANDARD SECTION
55G - 10' Section

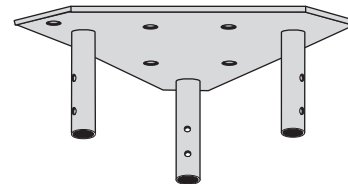

TOP PLATE
APL55G
FOR MOUNTING BEACON OR LIGHTNING ROD.
TOP PLATE BOLTS TO THE TOP OF
A STANDARD SECTION.

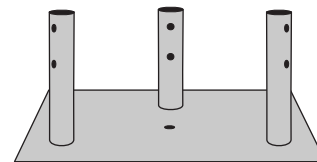

CONCRETE BASE PLATE
BPC55G*
FOR USE WITH 3/4X12PP PIER PIN
EMBEDDED IN CONCRETE.

Additional base sections are available, please see page 115.

* Towers mounted on these bases must be bracketed or guyed at all times. Temporary steel guying may also be necessary during installation and dismantling.



BUYERS GUIDE
STANDARD DESIGNS - 55G
90MPH REV. G [3 SECOND GUST]
70MPH REV. F [FASTEST MILE]

Design Criteria

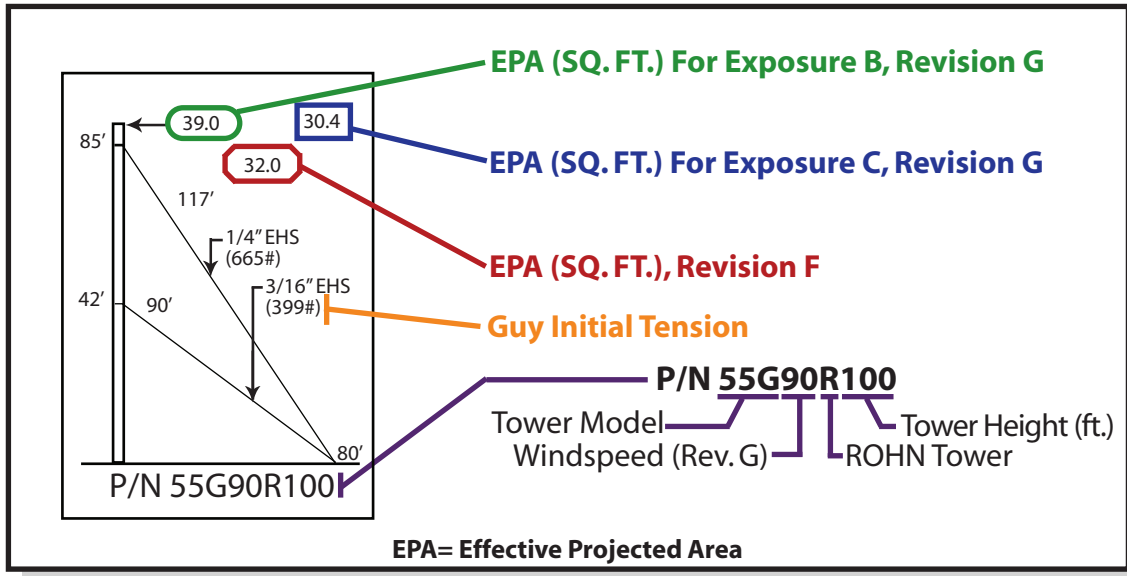

This document is to serve as a guide for sizing and purchasing the 55G tower. Tower and foundation installations should be performed by qualified and experienced personnel using assembly drawings provided with each tower.

DESIGN NOTES:

- 1. Tower designs are in accordance with ANSI/TIA-222-F and ANSI/TIA-222-G, Class I Structures, Topographic Category 1.
2. Design assumes towers are installed on level ground. Lower EPA values will apply for roof mounted towers or for sites located on unusual terrain.
3. Designs assume two 1/2" diameter lines on each tower face.
4. Anchor radius is from tower base to intersection of anchor rod with ground.
5. Guy chord lengths shown are based on level ground. Initial tensions for guys are shown in () in pounds at 60° Fahrenheit.
6. Antenna and mounts are assumed symmetrically placed at the tower top.

PARTS LIST NOTES:

- 1. Items listed are required for complete guyed towers.
2. Base and anchor foundations listed refer to standard foundation designations.
3. Guys provided with each standard tower are based on level ground conditions with an additional 6% length.
4. Rev G anchor grounding (AGK1GGX) and base grounding (BGK2GGX) are included with the tower material.
5. Assembly drawings and a safety package (P/N: ACWS) are included with each tower.
6. Parts lists are subject to change based on availability or revised design criteria.

FOR FOUNDATION INFORMATION, PLEASE SEE PAGES 117-120.
FOR GENERAL INSTALLATION INFORMATION, PLEASE SEE PAGES 147-153.



STANDARD DESIGN - 55G

90 MPH REV. G, 70MPH REV. F

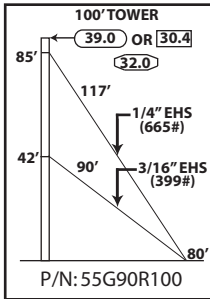

TOWER PARTS INCLUDED	55G	BPC55G	APL55G	GA55GD	FDNS		
	10	1	1	2	BASE CB1G	ANCHOR AB2	
GUYS & CONNECTIONS INCLUDED	3/16EHS	1/4EHS	BG2142	BG2144	5/16THH	3/8THH	1/2TBE&J
	300'	375'	6	6	6	6	6
ANCHORS & GROUNDING INCLUDED	GAC3455TOP	AGK1GGX	BGK2GGX	CPC.5/.75	TBSAFETY	3/4x12PP	
	3	1	3	3	3	1	

100' ROHN 55G
All parts shown in table are included when ordering
Part No: 55G90R100

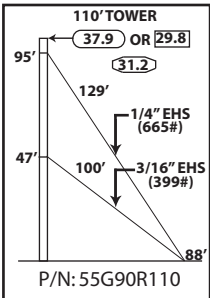

TOWER PARTS INCLUDED	55G	BPC55G	APL55G	GA55GD	FDNS		
	11	1	1	2	BASE CB1G	ANCHOR AB2	
GUYS & CONNECTIONS INCLUDED	3/16EHS	1/4EHS	BG2142	BG2144	5/16THH	3/8THH	1/2TBE&J
	325'	425'	6	6	6	6	6
ANCHORS & GROUNDING INCLUDED	GAC3455TOP	AGK1GGX	BGK2GGX	CPC.5/.75	TBSAFETY	3/4x12PP	
	3	1	3	3	3	1	

110' ROHN 55G
All parts shown in table are included when ordering
Part No: 55G90R110

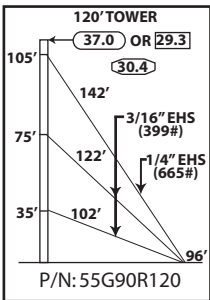

TOWER PARTS INCLUDED	55G	BPC55G	APL55G	GA55GD	FDNS		
	12	1	1	3	BASE CB1G	ANCHOR AB2	
GUYS & CONNECTIONS INCLUDED	3/16EHS	1/4EHS	BG2142	BG2144	5/16THH	3/8THH	1/2TBE&J
	725'	475'	12	6	12	6	9
ANCHORS & GROUNDING INCLUDED	GAC3455TOP	AGK1GGX	BGK2GGX	CPC.5/.75	TBSAFETY	3/4x12PP	
	3	1	3	3	3	1	

120' ROHN 55G
All parts shown in table are included when ordering
Part No: 55G90R120

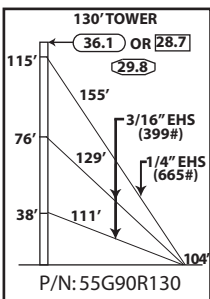

TOWER PARTS INCLUDED	55G	BPC55G	APL55G	GA55GD	FDNS		
	13	1	1	3	BASE CB1G	ANCHOR AB2	
GUYS & CONNECTIONS INCLUDED	3/16EHS	1/4EHS	BG2142	BG2144	5/16THH	3/8THH	1/2TBE&J
	775'	500'	12	6	12	6	9
ANCHORS & GROUNDING INCLUDED	GAC3455TOP	AGK1GGX	BGK2GGX	CPC.5/.75	TBSAFETY	3/4x12PP	
	3	1	3	3	3	1	

130' ROHN 55G
All parts shown in table are included when ordering
Part No: 55G90R130

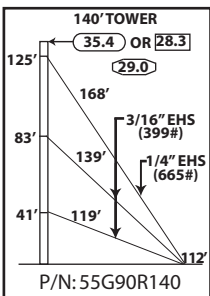

TOWER PARTS INCLUDED	55G	BPC55G	APL55G	GA55GD	FDNS		
	14	1	1	3	BASE CB1G	ANCHOR AB2	
GUYS & CONNECTIONS INCLUDED	3/16EHS	1/4EHS	BG2142	BG2144	5/16THH	3/8THH	1/2TBE&J
	825'	550'	12	6	12	6	9
ANCHORS & GROUNDING INCLUDED	GAC3455TOP	AGK1GGX	BGK2GGX	CPC.5/.75	TBSAFETY	3/4x12PP	
	3	1	3	3	3	1	

140' ROHN 55G
All parts shown in table are included when ordering
Part No: 55G90R140



STANDARD DESIGN - 55G
90MPH REV. G, 70MPH REV. F

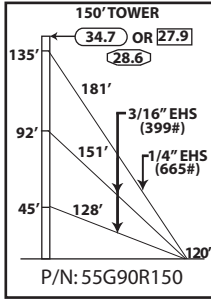

TOWER PARTS INCLUDED	55G	BPC55G	APL55G	GA55GD	FDNS		
					BASE	ANCHOR	
	15	1	1	3	CB2G	AB2	
GUYS & CONNECTIONS INCLUDED	3/16EHS	1/4EHS	BG2142	BG2144	5/16THH	3/8THH	1/2TBE&J
	900'	600'	12	6	12	6	9
ANCHORS & GROUNDING INCLUDED	GAC3455TOP	AGK1GGX	BGK2GGX	CPC.5/.75	TBSAFETY	3/4x12PP	
	3	1	3	3	3	1	

150' ROHN 55G
All parts shown in table are included when ordering
Part No: 55G90R150

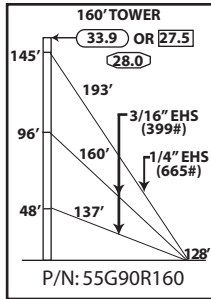

TOWER PARTS INCLUDED	55G	BPC55G	APL55G	GA55GD	FDNS		
					BASE	ANCHOR	
	16	1	1	3	CB2G	AB2	
GUYS & CONNECTIONS INCLUDED	3/16EHS	1/4EHS	BG2142	BG2144	5/16THH	3/8THH	1/2TBE&J
	950'	625'	12	6	12	6	9
ANCHORS & GROUNDING INCLUDED	GAC3455TOP	AGK1GGX	BGK2GGX	CPC.5/.75	TBSAFETY	3/4x12PP	
	3	1	3	3	3	1	

160' ROHN 55G
All parts shown in table are included when ordering
Part No: 55G90R160

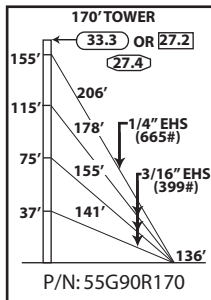

TOWER PARTS INCLUDED	55G	BPC55G	APL55G	GA55GD	FDNS		
					BASE	ANCHOR	
	17	1	1	4	CB2G	AB2	
GUYS & CONNECTIONS INCLUDED	3/16EHS	1/4EHS	BG2142	BG2144	5/16THH	3/8THH	1/2TBE&J
	1525'	675'	18	6	18	6	12
ANCHORS & GROUNDING INCLUDED	GAC3455TOP	AGK1GGX	BGK2GGX	CPC.5/.75	TBSAFETY	3/4x12PP	
	3	1	3	3	3	1	

170' ROHN 55G
All parts shown in table are included when ordering
Part No: 55G90R170

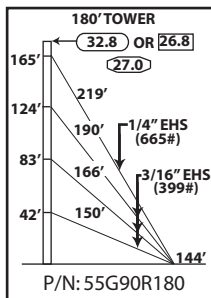

TOWER PARTS INCLUDED	55G	BPC55G	APL55G	GA55GD	FDNS		
					BASE	ANCHOR	
	18	1	1	4	CB2G	AB2	
GUYS & CONNECTIONS INCLUDED	3/16EHS	1/4EHS	BG2142	BG2144	5/16THH	3/8THH	1/2TBE&J
	1625'	700'	18	6	18	6	12
ANCHORS & GROUNDING INCLUDED	GAC3455TOP	AGK1GGX	BGK2GGX	CPC.5/.75	TBSAFETY	3/4x12PP	
	3	1	3	3	3	1	

180' ROHN 55G
All parts shown in table are included when ordering
Part No: 55G90R180

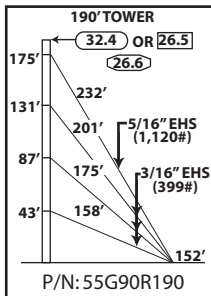

TOWER PARTS INCLUDED	55G	BPC55G	APL55G	GA55GD	FDNS		
					BASE	ANCHOR	
	19	1	1	4	CB2G	AB3	
GUYS & CONNECTIONS INCLUDED	3/16EHS	1/4EHS	BG2142	BG2146	5/16THH	7/16THH	5/8TBE&J
	1700'	750'	18	6	18	6	12
ANCHORS & GROUNDING INCLUDED	GAC5655TOP	AGK1GGX	BGK2GGX	CPC1/1.25	TBSAFETY	3/4x12PP	
	3	1	3	3	3	1	

190' ROHN 55G
All parts shown in table are included when ordering
Part No: 55G90R190



STANDARD DESIGN - 55G 90MPH REV. G, 70MPH REV. F

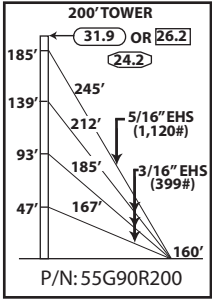

TOWER PARTS INCLUDED	55G	BPC55G	APL55G	GA55GD	FDNS		
	20	1	1	4	BASE CB2G	ANCHOR AB3	
GUYS & CONNECTIONS INCLUDED	3/16EHS	142265	BG2142	BG2146	5/16THH	7/16THH	5/8TBE&J
	1800'	800'	18	6	18	6	12
ANCHORS & GROUNDING INCLUDED	GAC5655TOP	AGK1GGX	BGK2GGX	CPC1/1.25	TBSAFETY	3/4x12PP	
	3	1	3	3	3	1	

200' ROHN 55G
All parts shown in table are included when ordering
Part No: 55G90R200

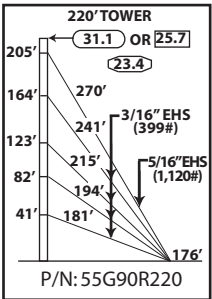

TOWER PARTS INCLUDED	55G	BPC55G	APL55G	GA55GD	FDNS		
	22	1	1	5	BASE CB2G	ANCHOR AB3	
GUYS & CONNECTIONS INCLUDED	3/16EHS	142265	BG2142	BG2146	5/16THH	7/16THH	3/4TBE&J
	2650'	875'	24	6	24	6	15
ANCHORS & GROUNDING INCLUDED	GAC5755TOP	AGK1GGX	BGK2GGX	CPC1.5/2	TBSAFETY	3/4x12PP	
	3	1	3	3	3	1	

220' ROHN 55G
All parts shown in table are included when ordering
Part No: 55G90R220

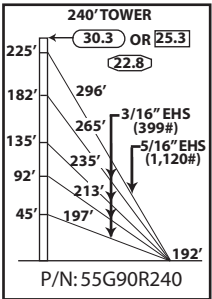

TOWER PARTS INCLUDED	55G	BPC55G	APL55G	GA55GD	FDNS		
	24	1	1	5	BASE CB3G	ANCHOR AB3	
GUYS & CONNECTIONS INCLUDED	3/16EHS	142265	BG2142	BG2146	5/16THH	7/16THH	3/4TBE&J
	2900'	950'	24	6	24	6	15
ANCHORS & GROUNDING INCLUDED	GAC5755TOP	AGK1GGX	BGK2GGX	CPC1.5/2	TBSAFETY	3/4x12PP	
	3	1	3	3	3	1	

240' ROHN 55G
All parts shown in table are included when ordering
Part No: 55G90R240

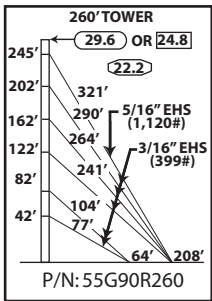

TOWER PARTS INCLUDED	55G	BPC55G	APL55G	GA55GD	BASE	INNER ANCHOR	OUTER ANCHOR
	26	1	1	6	CB3G	AB2	AB3
GUYS & CONNECTIONS INCLUDED	3/16EHS	142265	BG2142	BG2146	5/16THH		
	3125'	1025'	30	6	30		
	7/16THH	1/2TBE&J	5/8TBE&J	CPC.5/1.75	CPC1/1.25		
ANCHORS & GROUNDING INCLUDED	GAC3455TOP	GAC5655TOP	AGK1GGX	BGK2GGX	TBSAFETY	3/4x12PP	
	3	3	2	3	6	1	

260' ROHN 55G
All parts shown in table are included when ordering
Part No: 55G90R260



STANDARD DESIGN - 55G
90MPH REV. G, 70MPH REV. F

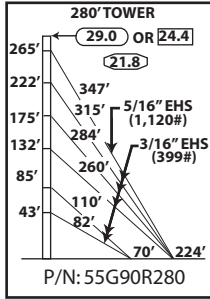

TOWER PARTS INCLUDED	55G	BPC55G	APL55G	GA55GD	BASE	INNER ANCHOR	OUTER ANCHOR
		28	1	1	6	CB4G	AB2
GUYS & CONNECTIONS INCLUDED	3/16EHS	142265	BG2142	BG2146	5/16THH		
	3350	1125'	30	6	30		
	7/16THH	1/2TBE&J	5/8TBE&J	CPC.5/.75	CPC1/1.25		
	6	6	12	3	3		
ANCHORS & GROUNDING INCLUDED	GAC3455TOP	GAC5655TOP	AGK1GGX	BGK2GGX	TBSAFETY	3/4x12PP	
	3	3	2	3	6	1	

280' ROHN 55G
All parts shown in table are included when ordering
Part No: 55G90R280

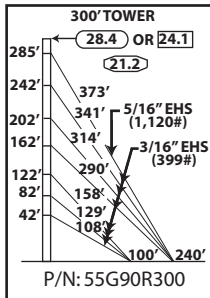

TOWER PARTS INCLUDED	55G	BPC55G	APL55G	GA55GD	BASE	INNER ANCHOR	OUTER ANCHOR
		30	1	1	7	CB4G	AB2
GUYS & CONNECTIONS INCLUDED	3/16EHS	142265	BG2142	BG2146	5/16THH		
	4275'	1200'	36	6	36		
	7/16THH	1/2TBE&J	5/8TBE&J	CPC.5/.75	CPC1/1.25		
	6	9	12	3	3		
ANCHORS & GROUNDING INCLUDED	GAC3455TOP	GAC5655TOP	AGK1GGX	BGK2GGX	TBSAFETY	3/4x12PP	
	3	3	2	3	6	1	

300' ROHN 55G
All parts shown in table are included when ordering
Part No: 55G90R300

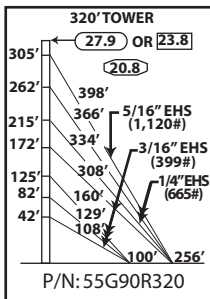

TOWER PARTS INCLUDED	55G	BPC55G	APL55G	GA55GD	BASE	INNER ANCHOR	OUTER ANCHOR
		32	1	1	7	CB4G	AB2
GUYS & CONNECTIONS INCLUDED	3/16EHS	1/4EHS	142265	BG2142	BG2144	BG2146	
	2250'	2250'	1275'	24	12	6	
	5/16THH	3/8THH	7/16THH	1/2TBE&J	5/8TBE&J	TBSAFETY	
	24	12	6	9	12	6	
ANCHORS & GROUNDING INCLUDED	GAC3455TOP	GAC5655TOP	AGK1GGX	BGK2GGX	CPC.5/.75	CPC1/1.25	3/4x12PP
	3	3	2	3	3	3	1

320' ROHN 55G
All parts shown in table are included when ordering
Part No: 55G90R320

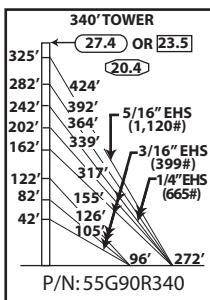

TOWER PARTS INCLUDED	55G	BPC55G	APL55G	GA55GD	BASE	INNER ANCHOR	OUTER ANCHOR
		34	1	1	8	CB4G	AB2
GUYS & CONNECTIONS INCLUDED	3/16EHS	1/4EHS	142265	BG2142	BG2144	BG2146	
	3325'	2425'	1350'	30	12	6	
	5/16THH	3/8THH	7/16THH	1/2TBE&J	5/8TBE&J	TBSAFETY	
	30	12	6	9	15	6	
ANCHORS & GROUNDING INCLUDED	GAC3455TOP	GAC5655TOP	AGK1GGX	BGK2GGX	CPC.5/.75	CPC1/1.25	3/4x12PP
	3	3	2	3	3	3	1

340' ROHN 55G
All parts shown in table are included when ordering
Part No: 55G90R340



STANDARD DESIGN - 55G 90MPH REV.G, 70MPH REV. F

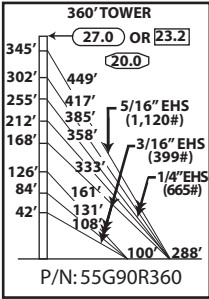

TOWER PARTS INCLUDED	55G	BPC55G	APL55G	GA55GD	APL1258UM	BASE	INNER ANCHOR	OUTER ANCHOR
		36	1	1	8	2	CB5G	AB2
GUYS & CONNECTIONS INCLUDED	3/16EHS	1/4EHS	142265	BG2142	BG2144	BG2146		
	3475'	2575'	1450'	30	12	6		
	5/16THH	3/8THH	7/16THH	1/2TBE&J	5/8TBE&J	TBSAFETY		
	30	12	6	9	15	6		
ANCHORS & GROUNDING INCLUDED	GAC3455TOP	GAC5655TOP	AGK1GGX	BGK2GGX	CPC.5/.75	CPC1/1.25		
	3	3	2	3	3	3		

360' ROHN 55G
All parts shown in table are included when ordering Part No: 55G90R360

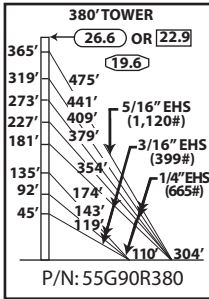

TOWER PARTS INCLUDED	55G	BPC55G	APL55G	GA55GD	APL1258UM	BASE	INNER ANCHOR	OUTER ANCHOR
		38	1	1	8	2	CB5G	AB2
GUYS & CONNECTIONS INCLUDED	3/16EHS	1/4EHS	142265	BG2142	BG2144	BG2146		
	3175'	3275'	1525'	24	18	6		
	5/16THH	3/8THH	7/16THH	1/2TBE&J	5/8TBE&J	TBSAFETY		
	24	18	6	9	15	6		
ANCHORS & GROUNDING INCLUDED	GAC3455TOP	GAC5655TOP	AGK1GGX	BGK2GGX	CPC.5/.75	CPC1/1.25	3/4x12PP	
	3	3	2	3	3	3	1	

380' ROHN 55G
All parts shown in table are included when ordering Part No: 55G90R380

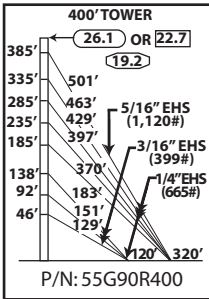

TOWER PARTS INCLUDED	55G	BPC55G	APL55G	GA55GD	APL1258UM	BASE	INNER ANCHOR	OUTER ANCHOR
		40	1	1	8	2	CB5G	AB2
GUYS & CONNECTIONS INCLUDED	3/16EHS	1/4EHS	142265	BG2142	BG2144	BG2146		
	2075'	4700'	1600'	18	24	6		
	5/16THH	3/8THH	7/16THH	1/2TBE&J	5/8TBE&J	TBSAFETY		
	18	24	6	9	15	6		
ANCHORS & GROUNDING INCLUDED	GAC3455TOP	GAC5655TOP	AGK1GGX	BGK2GGX	CPC.5/.75	CPC1/1.25	3/4x12PP	
	3	3	2	3	3	3	1	

400' ROHN 55G
All parts shown in table are included when ordering Part No: 55G90R400



STANDARD DESIGN - 55G

110MPH REV.G, 90MPH REV. F

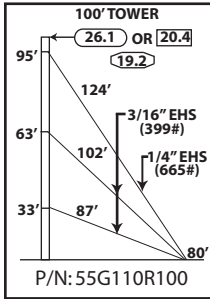

TOWER PARTS INCLUDED	55G	BPC55G	APL55G	GA55GD	FDNS		
					BASE	ANCHOR	
	10	1	1	3	CB1G	AB2	
GUYS & CONNECTIONS INCLUDED	3/16EHS	1/4EHS	BG2142	BG2144	5/16THH	3/8THH	1/2TBE&J
	600'	400'	12	6	12	6	9
ANCHORS & GROUNDING INCLUDED	GAC3455TOP	AGK1GGX	BGK2GGX	CPC.5/.75	TBSAFETY	3/4x12PP	
	3	1	3	3	3	1	

100' ROHN 55G
All parts shown in table are included when ordering
Part No: 55G110R100

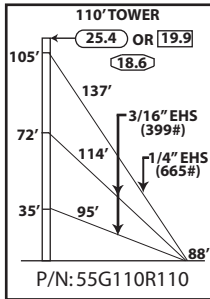

TOWER PARTS INCLUDED	55G	BPC55G	APL55G	GA55GD	FDNS		
					BASE	ANCHOR	
	11	1	1	3	CB1G	AB2	
GUYS & CONNECTIONS INCLUDED	3/16EHS	1/4EHS	BG2142	BG2144	5/16THH	3/8THH	1/2TBE&J
	675'	450'	12	6	12	6	9
ANCHORS & GROUNDING INCLUDED	GAC3455TOP	AGK1GGX	BGK2GGX	CPC.5/.75	TBSAFETY	3/4x12PP	
	3	1	3	3	3	1	

110' ROHN 55G
All parts shown in table are included when ordering
Part No: 55G110R110

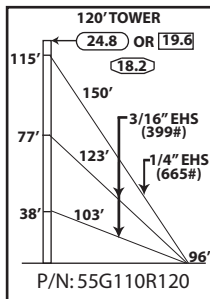

TOWER PARTS INCLUDED	55G	BPC55G	APL55G	GA55GD	FDNS		
					BASE	ANCHOR	
	12	1	1	3	CB2G	AB2	
GUYS & CONNECTIONS INCLUDED	3/16EHS	1/4EHS	BG2142	BG2144	5/16THH	3/8THH	1/2TBE&J
	725'	500'	12	6	12	6	9
ANCHORS & GROUNDING INCLUDED	GAC3455TOP	AGK1GGX	BGK2GGX	CPC.5/.75	TBSAFETY	3/4x12PP	
	3	1	3	3	3	1	

120' ROHN 55G
All parts shown in table are included when ordering
Part No: 55G110R120

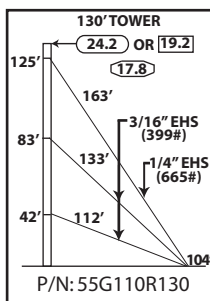

TOWER PARTS INCLUDED	55G	BPC55G	APL55G	GA55GD	FDNS		
					BASE	ANCHOR	
	13	1	1	3	CB2G	AB2	
GUYS & CONNECTIONS INCLUDED	3/16EHS	1/4EHS	BG2142	BG2144	5/16THH	3/8THH	1/2TBE&J
	800'	525'	12	6	12	6	9
ANCHORS & GROUNDING INCLUDED	GAC3455TOP	AGK1GGX	BGK2GGX	CPC.5/.75	TBSAFETY	3/4x12PP	
	3	1	3	3	3	1	

130' ROHN 55G
All parts shown in table are included when ordering
Part No: 55G110R130

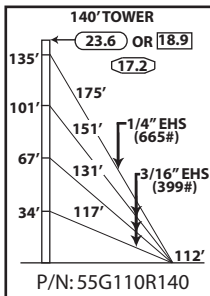

TOWER PARTS INCLUDED	55G	BPC55G	APL55G	GA55GD	FDNS		
					BASE	ANCHOR	
	14	1	1	4	CB2G	AB2	
GUYS & CONNECTIONS INCLUDED	3/16EHS	1/4EHS	BG2142	BG2144	5/16THH	3/8THH	1/2TBE&J
	1275'	575'	18	6	18	6	12
ANCHORS & GROUNDING INCLUDED	GAC3455TOP	AGK1GGX	BGK2GGX	CPC.5/.75	TBSAFETY	3/4x12PP	
	3	1	3	3	3	1	

140' ROHN 55G
All parts shown in table are included when ordering
Part No: 55G110R140



STANDARD DESIGN - 55G
110MPH REV.G, 90MPH REV. F

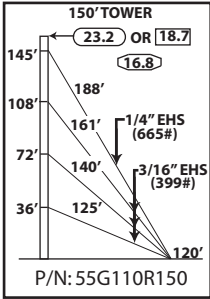

TOWER PARTS INCLUDED	55G	BPC55G	APL55G	GA55GD	FDNS		
	15	1	1	4	BASE CB2G	ANCHOR AB3	
GUYS & CONNECTIONS INCLUDED	3/16EHS	1/4EHS	BG2142	BG2144	5/16THH	3/8THH	5/8TBE&J
	1375'	600'	18	6	18	6	12
ANCHORS & GROUNDING INCLUDED	GAC555TOP	AGK1GGX	BGK2GGX	CPC1/1.25	TBSAFETY	3/4x12PP	
	3	1	3	3	3	1	

150' ROHN 55G
All parts shown in table are included when ordering
Part No: 55G110R150

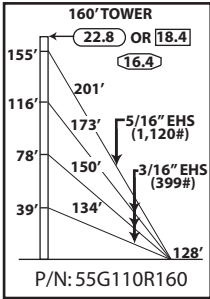

TOWER PARTS INCLUDED	55G	BPC55G	APL55G	GA55GD	FDNS		
	16	1	1	4	BASE CB2G	ANCHOR AB3	
GUYS & CONNECTIONS INCLUDED	3/16EHS	142265	BG2142	BG2146	5/16THH	7/16THH	5/8TBE&J
	1475'	650'	18	6	18	6	12
ANCHORS & GROUNDING INCLUDED	GAC555TOP	AGK1GGX	BGK2GGX	CPC1/1.25	TBSAFETY	3/4x12PP	
	3	1	3	3	3	1	

160' ROHN 55G
All parts shown in table are included when ordering
Part No: 55G110R160

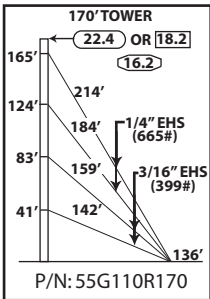

TOWER PARTS INCLUDED	55G	BPC55G	APL55G	GA55GD	FDNS		
	17	1	1	4	BASE CB2G	ANCHOR AB3	
GUYS & CONNECTIONS INCLUDED	3/16EHS	1/4EHS	BG2142	BG2144	5/16THH	3/8THH	5/8TBE&J
	975'	1275'	12	12	12	12	12
ANCHORS & GROUNDING INCLUDED	GAC555TOP	AGK1GGX	BGK2GGX	CPC1/1.25	TBSAFETY	3/4x12PP	
	3	1	3	3	3	1	

170' ROHN 55G
All parts shown in table are included when ordering
Part No: 55G110R170

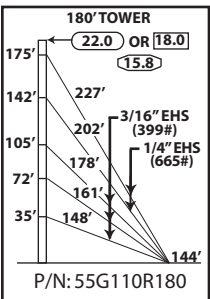

TOWER PARTS INCLUDED	55G	BPC55G	APL55G	GA55GD	FDNS		
	18	1	1	5	BASE CB3G	ANCHOR AB3	
GUYS & CONNECTIONS INCLUDED	3/16EHS	1/4EHS	BG2142	BG2144	5/16THH	3/8THH	5/8TBE&J
	1550'	1375'	18	12	18	12	15
ANCHORS & GROUNDING INCLUDED	GAC555TOP	AGK1GGX	BGK2GGX	CPC1/1.25	TBSAFETY	3/4x12PP	
	3	1	3	3	3	1	

180' ROHN 55G
All parts shown in table are included when ordering
Part No: 55G110R180

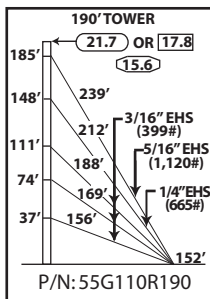

TOWER PARTS INCLUDED	55G	BPC55G	APL55G	GA55GD	FDNS	
	19	1	1	5	BASE CB3G	ANCHOR AB3
GUYS & CONNECTIONS INCLUDED	3/16EHS	1/4EHS	142265	BG2142	BG2144	
	1650'	675'	775'	18	6	
	BG2146	5/16THH	3/8THH	7/16THH	5/8TBE&J	
	6	18	6	6	15	
ANCHORS & GROUNDING INCLUDED	GAC555TOP	AGK1GGX	BGK2GGX	CPC1/1.25	TBSAFETY	3/4x12PP
	3	1	3	3	3	1

190' ROHN 55G
All parts shown in table are included when ordering
Part No: 55G110R190





STANDARD DESIGN - 55G
110MPH REV.G, 90MPH REV. F

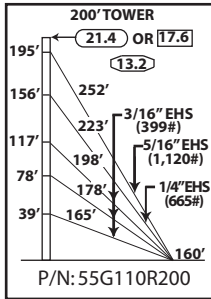

TOWER PARTS INCLUDED	55G	BPC55G	APL55G	GA55GD	FDNS	
					BASE	ANCHOR
	20	1	1	5	CB3G	AB3
GUYS & CONNECTIONS INCLUDED	3/16EHS	1/4EHS	142265	BG2142	BG2144	
	1750'	725'	825'	18	6	
	BG2146	5/16THH	3/8THH	7/16THH	5/8TBE&J	
	6	18	6	6	15	
ANCHORS & GROUNDING INCLUDED	GAC5655TOP	AGK1GGX	BGK2GGX	CPC1/1.25	TBSAFETY	3/4x12PP
	3	1	3	3	3	1

200' ROHN 55G
All parts shown in table are included when ordering
Part No: 55G110R200

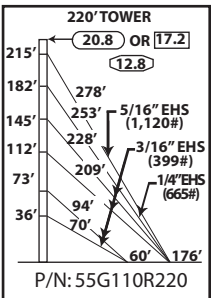

TOWER PARTS INCLUDED	55G	BPC55G	APL55G	GA55GD	BASE	INNER ANCHOR	OUTER ANCHOR
					CB4G	AB2	AB3
	22	1	1	6	CB4G	AB2	AB3
GUYS & CONNECTIONS INCLUDED	3/16EHS	1/4EHS	142265	BG2142	BG2144	BG2146	
	1925'	825'	900'	24	6	6	
	5/16THH	3/8THH	7/16THH	1/2TBE&J	5/8TBE&J	TBSAFETY	
	24	6	6	6	12	6	
ANCHORS & GROUNDING INCLUDED	GAC3455TOP	GAC5655TOP	AGK1GGX	BGK2GGX	CPC.5/1.75	CPC1/1.25	3/4x12PP
	3	3	2	3	3	3	1

220' ROHN 55G
All parts shown in table are included when ordering
Part No: 55G110R220

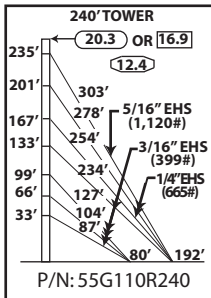

TOWER PARTS INCLUDED	55G	BPC55G	APL55G	GA55GD	BASE	INNER ANCHOR	OUTER ANCHOR
					CB4G	AB2	AB3
	24	1	1	7	CB4G	AB2	AB3
GUYS & CONNECTIONS INCLUDED	3/16EHS	1/4EHS	142265	BG2142	BG2144	BG2146	
	1775'	1700'	975'	24	12	6	
	5/16THH	3/8THH	7/16THH	1/2TBE&J	5/8TBE&J	TBSAFETY	
	24	12	6	9	12	6	
ANCHORS & GROUNDING INCLUDED	GAC3455TOP	GAC5655TOP	AGK1GGX	BGK2GGX	CPC.5/1.75	CPC1/1.25	3/4x12PP
	3	3	2	3	3	3	1

240' ROHN 55G
All parts shown in table are included when ordering
Part No: 55G110R240

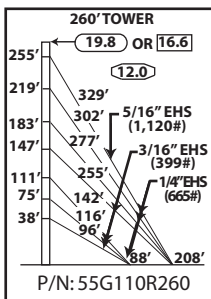

TOWER PARTS INCLUDED	55G	BPC55G	APL55G	GA55GD	BASE	INNER ANCHOR	OUTER ANCHOR
					CB5G	AB2	AB3
	26	1	1	7	CB5G	AB2	AB3
GUYS & CONNECTIONS INCLUDED	3/16EHS	1/4EHS	142265	BG2142	BG2144	BG2146	
	1500'	2300'	1050'	18	18	6	
	5/16THH	3/8THH	7/16THH	1/2TBE&J	5/8TBE&J	TBSAFETY	
	18	18	6	9	12	6	
ANCHORS & GROUNDING INCLUDED	GAC3455TOP	GAC5655TOP	AGK1GGX	BGK2GGX	CPC.5/1.75	CPC1/1.25	3/4x12PP
	3	3	2	3	3	3	1

260' ROHN 55G
All parts shown in table are included when ordering
Part No: 55G110R260



STANDARD DESIGN - 55G
110MPH REV.G, 90MPH REV. F

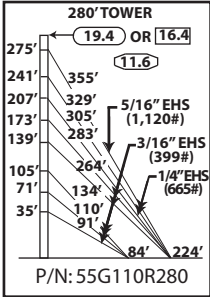

TOWER PARTS INCLUDED	55G	BPC55G	APL55G	GA55GD	BASE	INNER ANCHOR	OUTER ANCHOR	
	28	1	1	8	CB5G	AB2	AB4	
GUYS & CONNECTIONS INCLUDED	3/16EHS	1/4EHS	142265	BG2142	BG2144		BG2146	280' ROHN 55G All parts shown in table are included when ordering Part No: 55G110R280
	2825'	2025'	1150'	30	12		6	
	5/16THH	3/8THH	7/16THH	1/2TBE&J	5/8TBE&J		TBSAFETY	
	30	12	6	9	15		6	
ANCHORS & GROUNDING INCLUDED	GAC3455TOP	GAC5655TOP	AGK1GGX	BGK2GGX	CPC.5/.75		CPC1/1.25	3/4x12PP
	3	3	2	3	3		3	1

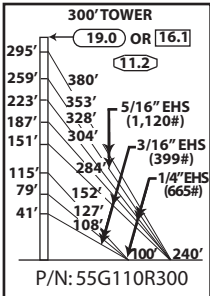

TOWER PARTS INCLUDED	55G	BPC55G	APL55G	GA55GD	BASE	INNER ANCHOR	OUTER ANCHOR	
	30	1	1	8	CB5G	AB2	AB4	
GUYS & CONNECTIONS INCLUDED	3/16EHS	1/4EHS	142265	BG2142	BG2144		BG2146	300' ROHN 55G All parts shown in table are included when ordering Part No: 55G110R300
	1675'	2500'	2350'	18	18		12	
	5/16THH	3/8THH	7/16THH	1/2TBE&J	5/8TBE&J		TBSAFETY	
	18	18	12	9	15		6	
ANCHORS & GROUNDING INCLUDED	GAC3455TOP	GAC5655TOP	AGK1GGX	BGK2GGX	CPC.5/.75		CPC1/1.25	3/4x12PP
	3	3	2	3	3		3	1



STANDARD DESIGN - 55G
130MPH REV.G, 110MPH REV.F

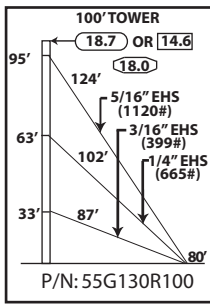

TOWER PARTS INCLUDED	55G	BPC55G	APL55G	GA55GD	FDNS	
					BASE	ANCHOR
	10	1	1	3	CB2G	AB2
GUYS & CONNECTIONS INCLUDED	3/16EHS	1/4EHS	142265	BG2142	BG2144	
	300'	325'	400'	6	6	
	BG2146	5/16THH	3/8THH	7/16THH	1/2TBE&J	5/8TBE&J
	6	6	6	6	6	3
ANCHORS & GROUNDING INCLUDED	GAC3455TOP	AGK1GGX	BGK2GGX	CPC.5/.75	TBSAFETY	3/4x12PP
	3	1	3	3	3	1

100' ROHN 55G
All parts shown in table are included when ordering
Part No: 55G130R100

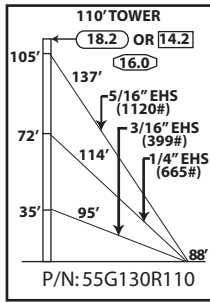

TOWER PARTS INCLUDED	55G	BPC55G	APL55G	GA55GD	FDNS	
					BASE	ANCHOR
	11	1	1	3	CB2G	AB3
GUYS & CONNECTIONS INCLUDED	3/16EHS	1/4EHS	142265	BG2142	BG2144	
	325'	375'	450'	6	6	
	BG2146	5/16THH	3/8THH	7/16THH	5/8TBE&J	
	6	6	6	6	9	
ANCHORS & GROUNDING INCLUDED	GAC5655TOP	AGK1GGX	BGK2GGX	CPC1/1.25	TBSAFETY	3/4x12PP
	3	1	3	3	3	1

110' ROHN 55G
All parts shown in table are included when ordering
Part No: 55G130R110

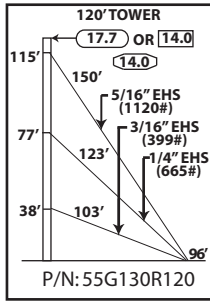

TOWER PARTS INCLUDED	55G	BPC55G	APL55G	GA55GD	FDNS	
					BASE	ANCHOR
	12	1	1	3	CB2G	AB3
GUYS & CONNECTIONS INCLUDED	3/16EHS	1/4EHS	142265	BG2142	BG2144	
	350'	400'	500'	6	6	
	BG2146	5/16THH	3/8THH	7/16THH	5/8TBE&J	
	6	6	6	6	9	
ANCHORS & GROUNDING INCLUDED	GAC5655TOP	AGK1GGX	BGK2GGX	CPC1/1.25	TBSAFETY	3/4x12PP
	3	1	3	3	3	1

120' ROHN 55G
All parts shown in table are included when ordering
Part No: 55G130R120

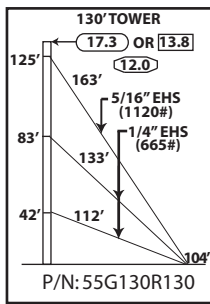

TOWER PARTS INCLUDED	55G	BPC55G	APL55G	GA55GD	FDNS	
					BASE	ANCHOR
	13	1	1	3	CB2G	AB3
GUYS & CONNECTIONS INCLUDED	1/4EHS	142265	BG2144	BG2146		
	800'	525'	12	6		
	3/8THH	7/16THH	5/8TBE&J	TBSAFETY		
	12	6	9	3		
ANCHORS & GROUNDING INCLUDED	GAC5655TOP	AGK1GGX	BGK2GGX	CPC1/1.25	3/4x12PP	
	3	1	3	3	1	

130' ROHN 55G
All parts shown in table are included when ordering
Part No: 55G130R130



STANDARD DESIGN - 55G 130MPH REV.G, 110MPH REV. F

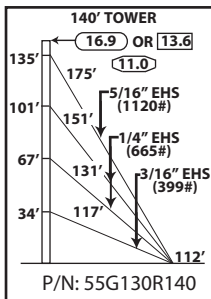

TOWER PARTS INCLUDED	55G	BPC55G	APL55G	GA55GD	FDNS	
					BASE	ANCHOR
	14	1	1	4	CB3G	AB3
GUYS & CONNECTIONS INCLUDED	3/16EHS	1/4EHS	142265	BG2142	BG2144	
	375'	900'	575'	6	12	
	BG2146	5/16THH	3/8THH	7/16THH	5/8TBE&J	
	6	6	12	6	12	
ANCHORS & GROUNDING INCLUDED	GAC555TOP	AGK1GGX	BGK2GGX	CPC1/1.25	TBSAFETY	3/4x12PP
	3	1	3	3	3	1

140' ROHN 55G
All parts shown in table are included when ordering
Part No: 55G130R140

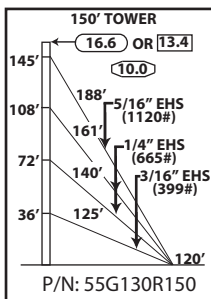

TOWER PARTS INCLUDED	55G	BPC55G	APL55G	GA55GD	FDNS	
					BASE	ANCHOR
	15	1	1	4	CB3G	AB3
GUYS & CONNECTIONS INCLUDED	3/16EHS	1/4EHS	142265	BG2142	BG2144	
	400'	975'	600'	6	12	
	BG2146	5/16THH	3/8THH	7/16THH	5/8TBE&J	
	6	6	12	6	12	
ANCHORS & GROUNDING INCLUDED	GAC555TOP	AGK1GGX	BGK2GGX	CPC1/1.25	TBSAFETY	3/4x12PP
	3	1	3	3	3	1

150' ROHN 55G
All parts shown in table are included when ordering
Part No: 55G130R150

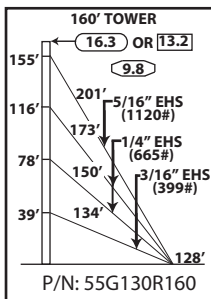

TOWER PARTS INCLUDED	55G	BPC55G	APL55G	GA55GD	FDNS	
					BASE	ANCHOR
	16	1	1	4	CB3G	AB3
GUYS & CONNECTIONS INCLUDED	3/16EHS	1/4EHS	142265	BG2142	BG2144	
	450'	1050'	650'	6	12	
	BG2146	5/16THH	3/8THH	7/16THH	5/8TBE&J	
	6	6	12	6	12	
ANCHORS & GROUNDING INCLUDED	GAC555TOP	AGK1GGX	BGK2GGX	CPC1/1.25	TBSAFETY	3/4x12PP
	3	1	3	3	3	1

160' ROHN 55G
All parts shown in table are included when ordering
Part No: 55G130R160

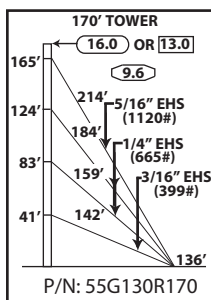

TOWER PARTS INCLUDED	55G	BPC55G	APL55G	GA55GD	FDNS	
					BASE	ANCHOR
	17	1	1	4	CB3G	AB4
GUYS & CONNECTIONS INCLUDED	3/16EHS	1/4EHS	142265	BG2142	BG2144	
	475'	1100'	700'	6	12	
	BG2146	5/16THH	3/8THH	7/16THH	3/4TBE&J	
	6	6	12	6	12	
ANCHORS & GROUNDING INCLUDED	GAC555TOP	AGK1GGX	BGK2GGX	CPC1.5/2	TBSAFETY	3/4x12PP
	3	1	3	3	3	1

170' ROHN 55G
All parts shown in table are included when ordering
Part No: 55G130R170





STANDARD DESIGN - 55G
130MPH REV.G, 110MPH REV. F

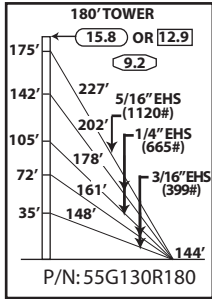

TOWER PARTS INCLUDED	55G	BPC55G	APL55G	GA55GD	FDNS	
					BASE	ANCHOR
	18	1	1	5	CB3G	AB4
GUYS & CONNECTIONS INCLUDED	3/16EHS	1/4EHS	142265	BG2142	BG2144	
	1000'	1225'	725'	12	12	
	BG2146	5/16THH	3/8THH	7/16THH	3/4TBE&J	
	6	12	12	6	15	
ANCHORS & GROUNDING INCLUDED	GAC5755TOP	AGK1GGX	BGK2GGX	CPC1.5/2	TBSAFETY	3/4x12PP
	3	1	3	3	3	1



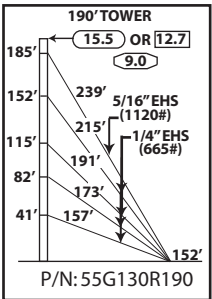

180' ROHN 55G
All parts shown in table are included when ordering
Part No: 55G130R180

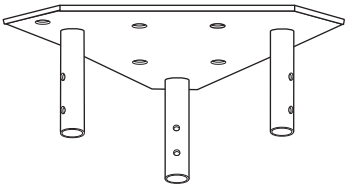
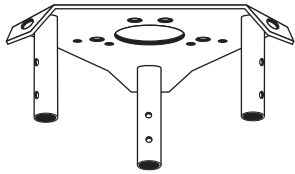
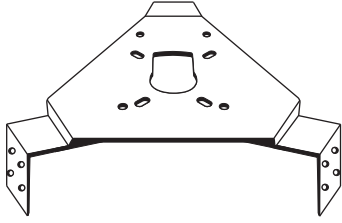
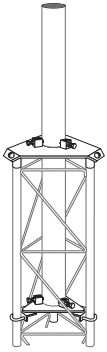

TOWER PARTS INCLUDED	55G	BPC55G	APL55G	GA55GD	FDNS	
					BASE	ANCHOR
	19	1	1	5	CB4G	AB4
GUYS & CONNECTIONS INCLUDED	1/4EHS	142265	BG2144	BG2146		
	2350'	775'	24	6		
	3/8THH	7/16THH	3/4TBE&J	TBSAFETY		
	24	6	15	3		
ANCHORS & GROUNDING INCLUDED	GAC5755TOP	AGK1GGX	BGK2GGX	CPC1.5/2	3/4x12PP	
	3	1	3	3	1	

190' ROHN 55G
All parts shown in table are included when ordering
Part No: 55G130R190

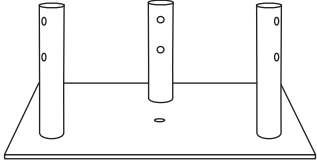
PARTS & ACCESSORIES

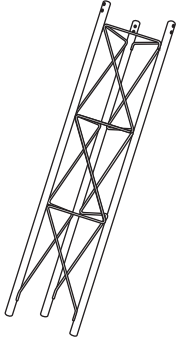
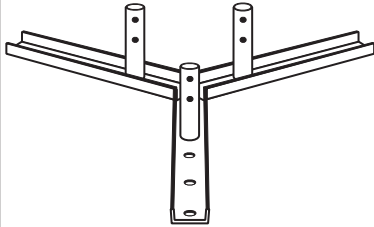
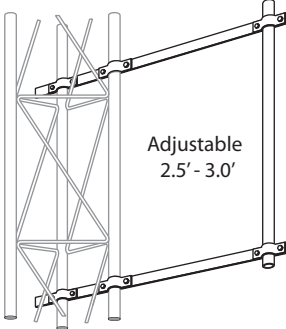
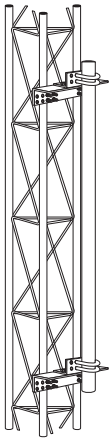
 <p>TOP PLATE APL55G FOR MOUNTING BEACON OR LIGHTNING ROD.</p>	 <p>BEARING PLATE BPL55G CONVERTS STANDARD SECTION TO A TOP SECTION. HOLE PATTERN FITS TB3 (2" O.D.) AND TB4 (3" O.D.) THRUST BEARING.</p>	 <p>ACCESSORY SHELF AS455G FOR MOUNTING MANY POPULAR ROTORS. FIELD DRILLING MAY BE NECESSARY FOR SOME ROTORS.</p>	 <p>TOP MOUNT 55TDMKD - NO MAST 55TDM2S3KD - 2 3/8" O.D. MAST 55TDM2S53KD - 2 7/8" O.D. MAST 55TDM3S3KD - 3 1/2" O.D. MAST 55TDM3S53KD - 4" O.D. MAST 55TDM4S3KD - 4 1/2" O.D. MAST MOUNTING TUBE PROVIDED IS 7'.</p>
 <p>LIGHTNING ROD LRCL 5' COPPER CLAD, MOUNTS TO APL55G.</p>	 <p>CONCRETE BASE PLATE BPC55G* FOR USE WITH 3/4X12PP PIER PIN EMBEDDED IN CONCRETE. CONCRETE BASE PLATE IS TO BE USED FOR BRACKETED AND GUYED APPLICATIONS ONLY.</p>	 <p>PIER PIN 3/4X12PP FOR USE WITH BPC55G EMBEDDED IN CONCRETE. PIER PIN MUST BE ORDERED SEPARATELY, UNLESS BEING PURCHASED AS PART OF A COMPLETE TOWER KIT.</p>	 <p>TAPERED BASE* 55TG - STANDARD 55TGIA - USE WITH A4197L BASE INSULATOR 55TGIAA - USE WITH A4722B BASE INSULATOR INSULATOR AND PIER PIN MUST BE ORDERED SEPARATELY.</p>
 <p>5' SHORT BASE SB55G FOR EMBEDMENT IN CONCRETE.</p>	 <p>FLAT ROOF MOUNT FR55G* BOLTS DIRECTLY TO FLAT ROOF SURFACE.</p>	 <p>SIDE ARM BRACKET SA253UA MOUNTING TUBE PROVIDED IS 3' LONG, 2 - 1/4" O.D. Adjustable 2.5' - 3.0'</p>	 <p>FACE MOUNT DM55G2 - 2 3/8" O.D. 5' LONG DM554 - 4 1/2" O.D. 5' LONG</p>

* TOWERS MOUNTED ON THESE BASES MUST BE BRACKETED OR GUYED AT ALL TIMES. TEMPORARY STEEL GUYING MAY ALSO BE NECESSARY DURING INSTALLATION AND DISMANTLING.



PARTS & ACCESSORIES

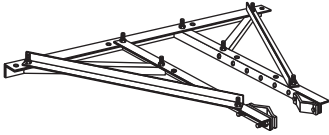

HEAVY DUTY UNIVERSAL HOUSE BRACKET
HBUTVRO
ADJUSTABLE TO POSITION TOWER 18" - 36" FROM WALL.

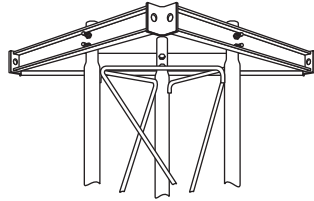

TORQUE ARM STABILIZER ASSEMBLY
TA55
ANTI-TWIST DEVICE LOCATED IN THE AREA OF ANTENNAS. PROVIDES SIX-WAY GUYING. BOLTS TO TOWER AT ANY SECTION JOINT. ATTACHED WITH JOINT BOLTS. MUST BE INSTALLED AS SECTIONS ARE JOINED TOGETHER.

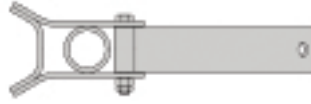

TORQUE BAR
TB55D
OPTIONAL, FOR USE WITH GA55GD. REQUIRES (1) 3/8" SHACKLE FOR EACH BAR.

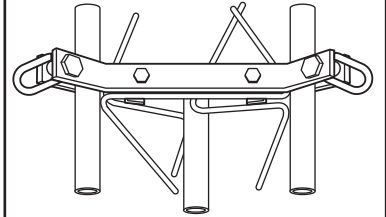

GUY BRACKET
GA55GD
MOUNTS TO TOWER AT ANY HORIZONTAL BRACE.

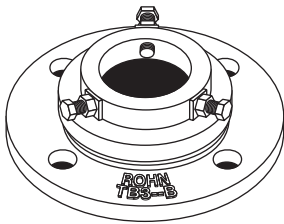

THRUST BEARING
TB3 - SUPPORTS UP TO 2" O.D. MAST.
TB4 - SUPPORTS UP TO 3" O.D. MAST.
MOUNTS TO BPL55G.



ANTI-CLIMB PANELS
455ACL3
THREE ANTI-CLIMB PANELS BOLT TO STANDARD TOWER SECTION.

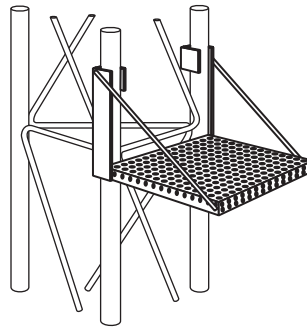

WORK PLATFORM
WP55G
SNAPS INTO PLACE AT ANY LEVEL. NO BOLTS REQUIRED.

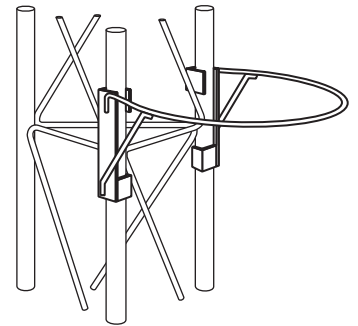

SAFETY RING
SR55
SNAPS INTO PLACE AT ANY LEVEL. NO BOLTS REQUIRED.



CLIMBING HARNESS
TTFBH-4D
JOURNEYMAN HARNESS
TTFBH-C/P
PROFESSIONAL HARNESS



SAFETY CABLE SLIDER WITH CARABINEER
TT-WG-500-W/SMC

SAFETY CABLE SYSTEM ORDERING INFORMATION

TOWER HEIGHT	PART NUMBER
50'	TT0504555
100'	TT1004555
150'	TT1504555
200'	TT2004555
250'	TT2504555
300'	TT3004555
350'	TT3504555
400'	TT4004555

SAFETY CABLE SLIDER AND CLIMBING HARNESS MUST BE ORDERED SEPARATELY.

ANCHOR INFORMATION

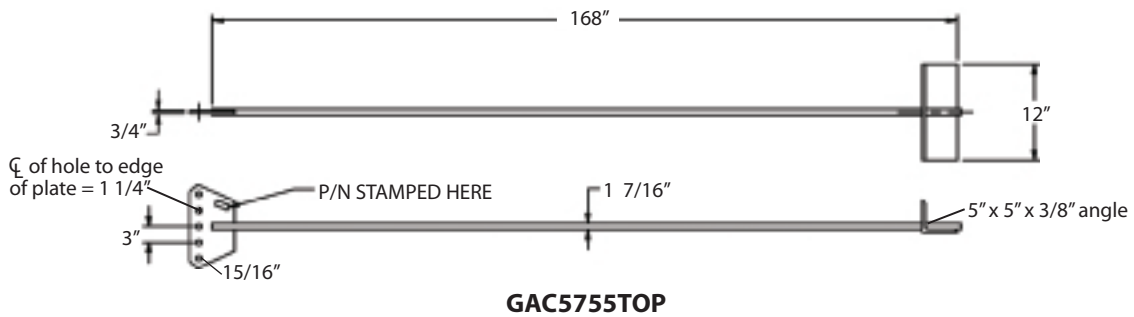
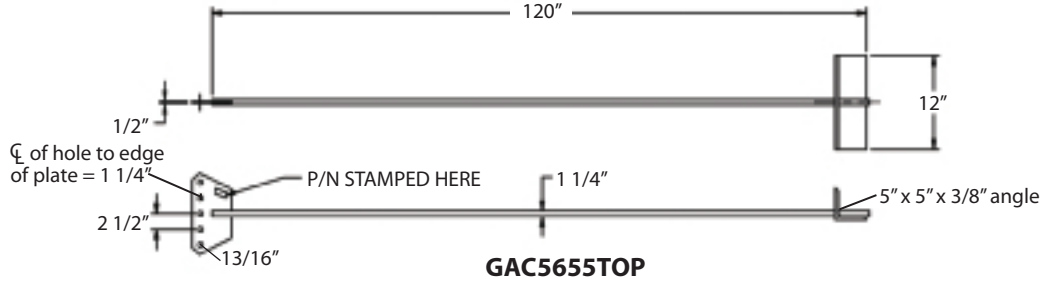
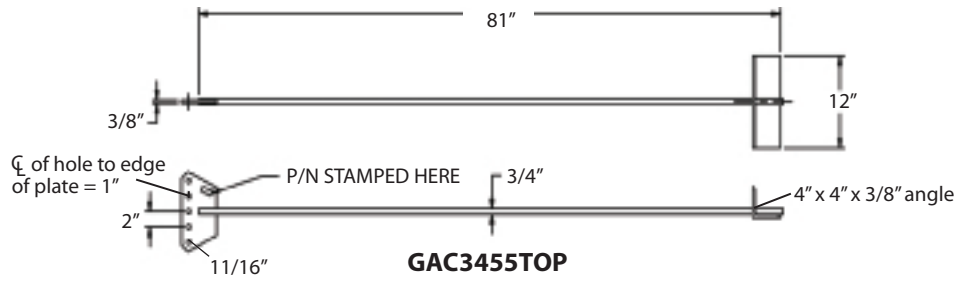

REV G
ANCHOR GROUNDING
AGK1GGX

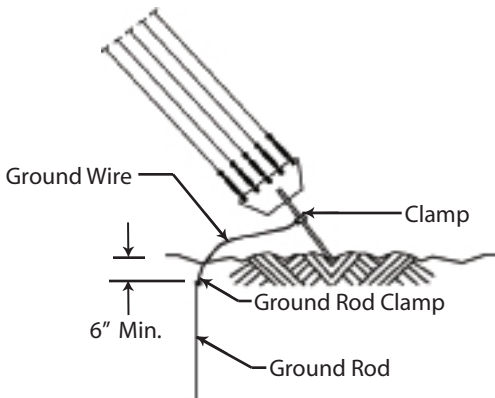

REV G
BASE GROUNDING
BGK2GGX

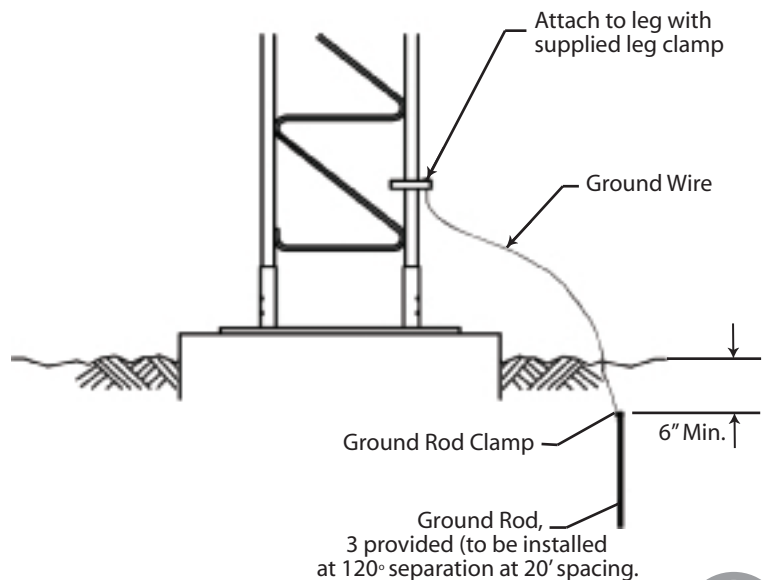



STANDARD ANCHOR BLOCKS

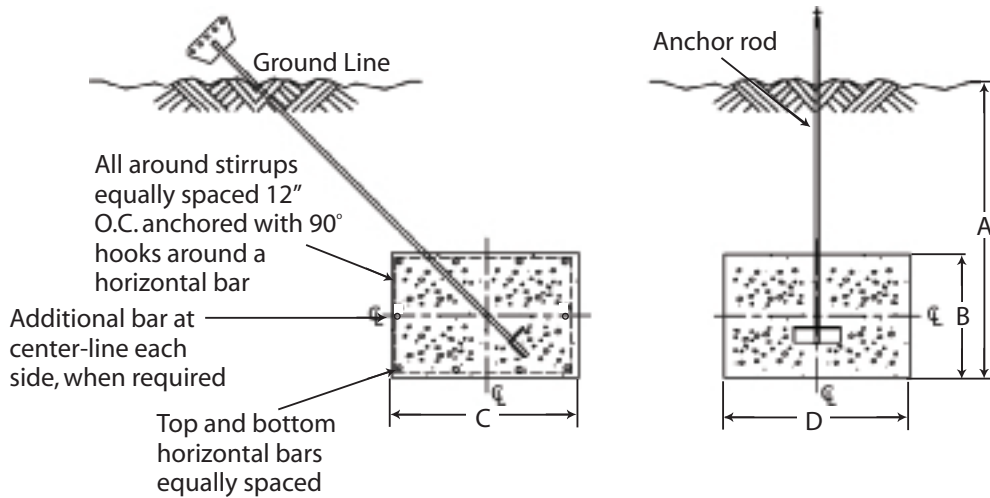

Refer to page 119 for anchor rod installation angles.

Block	Anchor Dimensions (in.)				Horizontal Bars (Qty. & Size)	Stirrup Size & Spacing	Concrete Vol. (Cu. Yds.)
	A	B	C	D			
AB2	4' - 0"	1' - 6"	4' - 0"	6' - 0"	(5) #6 Bars, Top Layer (5) #6 Bars, Bottom Layer (0) Additional Bar, Each Side	#3 @ 12" O.C.	1.33 Per Block 4.0 Total for 3
AB3	6' - 0"	1' - 6"	3' - 0"	6' - 0"	(4) #6 Bars, Top Layer (4) #6 Bars, Bottom Layer (0) Additional Bar, Each Side	#3 @ 12" O.C.	1.0 Per Block 3.0 Total for 3
AB4	6' - 0"	1' - 6"	4' - 0"	9' - 0"	(5) #6 Bars, Top Layer (5) #6 Bars, Bottom Layer (0) Additional Bar, Each Side	#4 @ 12" O.C.	2.0 Per Block 6.0 Total for 3
AB5	8' - 0"	2' - 0"	3' - 0"	10' - 0"	(4) #7 Bars, Top Layer (4) #7 Bars, Bottom Layer (1) Additional Bar, Each Side	#4 @ 12" O.C.	2.22 Per Block 6.7 Total for 3
AB6	8' - 0"	2' - 0"	4' - 0"	10' - 0"	(5) #7 Bars, Top Layer (5) #7 Bars, Bottom Layer (1) Additional Bar, Each Side	#4 @ 12" O.C.	2.96 Per Block 8.9 Total for 3



ANCHOR ROD INSTALLATION ANGLES

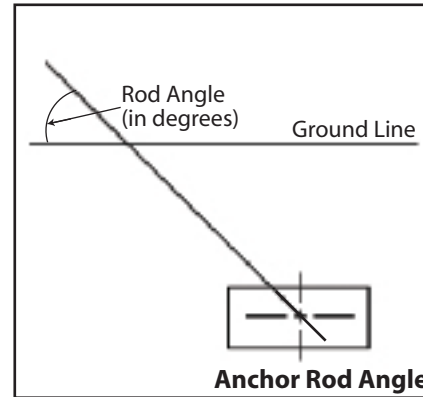
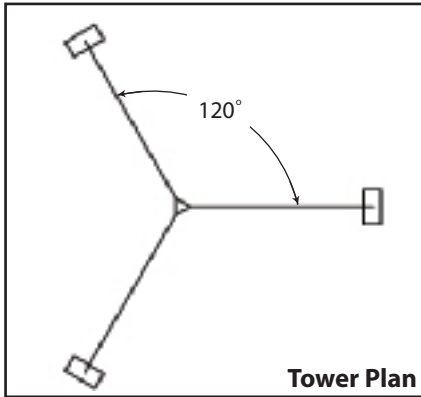

55G 90MPH				
Tower Height	Inner Rod Number	Inner Rod Angle	Outer Rod Number	Outer Rod Angle
100'	GAC3455TOP	42	-	-
110'	GAC3455TOP	42	-	-
120'	GAC3455TOP	40	-	-
130'	GAC3455TOP	40	-	-
140'	GAC3455TOP	40	-	-
150'	GAC3455TOP	39	-	-
160'	GAC3455TOP	39	-	-
170'	GAC3455TOP	38	-	-
180'	GAC3455TOP	38	-	-
190'	GAC5655TOP	40	-	-
200'	GAC5655TOP	40	-	-
220'	GAC5755TOP	38	-	-
240'	GAC5755TOP	37	-	-
260'	GAC3455TOP	43	GAC5655TOP	42
280'	GAC3455TOP	42	GAC5655TOP	42
300'	GAC3455TOP	39	GAC5655TOP	43
320'	GAC3455TOP	40	GAC5655TOP	43
340'	GAC3455TOP	40	GAC5655TOP	42
360'	GAC3455TOP	40	GAC5655TOP	42
380'	GAC3455TOP	40	GAC5655TOP	42
400'	GAC3455TOP	38	GAC5655TOP	42

55G 110MPH				
Tower Height	Inner Rod Number	Inner Rod Angle	Outer Rod Number	Outer Rod Angle
100'	GAC3455TOP	41	-	-
110'	GAC3455TOP	40	-	-
120'	GAC3455TOP	40	-	-
130'	GAC3455TOP	40	-	-
140'	GAC3455TOP	38	-	-
150'	GAC5655TOP	38	-	-
160'	GAC5655TOP	39	-	-
170'	GAC5655TOP	38	-	-
180'	GAC5655TOP	38	-	-
190'	GAC5655TOP	38	-	-
200'	GAC5655TOP	38	-	-
220'	GAC3455TOP	42	GAC5655TOP	43
240'	GAC3455TOP	40	GAC5655TOP	44
260'	GAC3455TOP	41	GAC5655TOP	44
280'	GAC3455TOP	40	GAC5655TOP	43
300'	GAC3455TOP	39	GAC5655TOP	43

55G 130MPH		
Tower Height	Rod Number	Rod Angle
100'	GAC3455TOP	41
110'	GAC5655TOP	40
120'	GAC5655TOP	40
130'	GAC5655TOP	40
140'	GAC5655TOP	40
150'	GAC5655TOP	40
160'	GAC5655TOP	40
170'	GAC5755TOP	38
180'	GAC5755TOP	38
190'	GAC5755TOP	37



STANDARD BASE PIERS

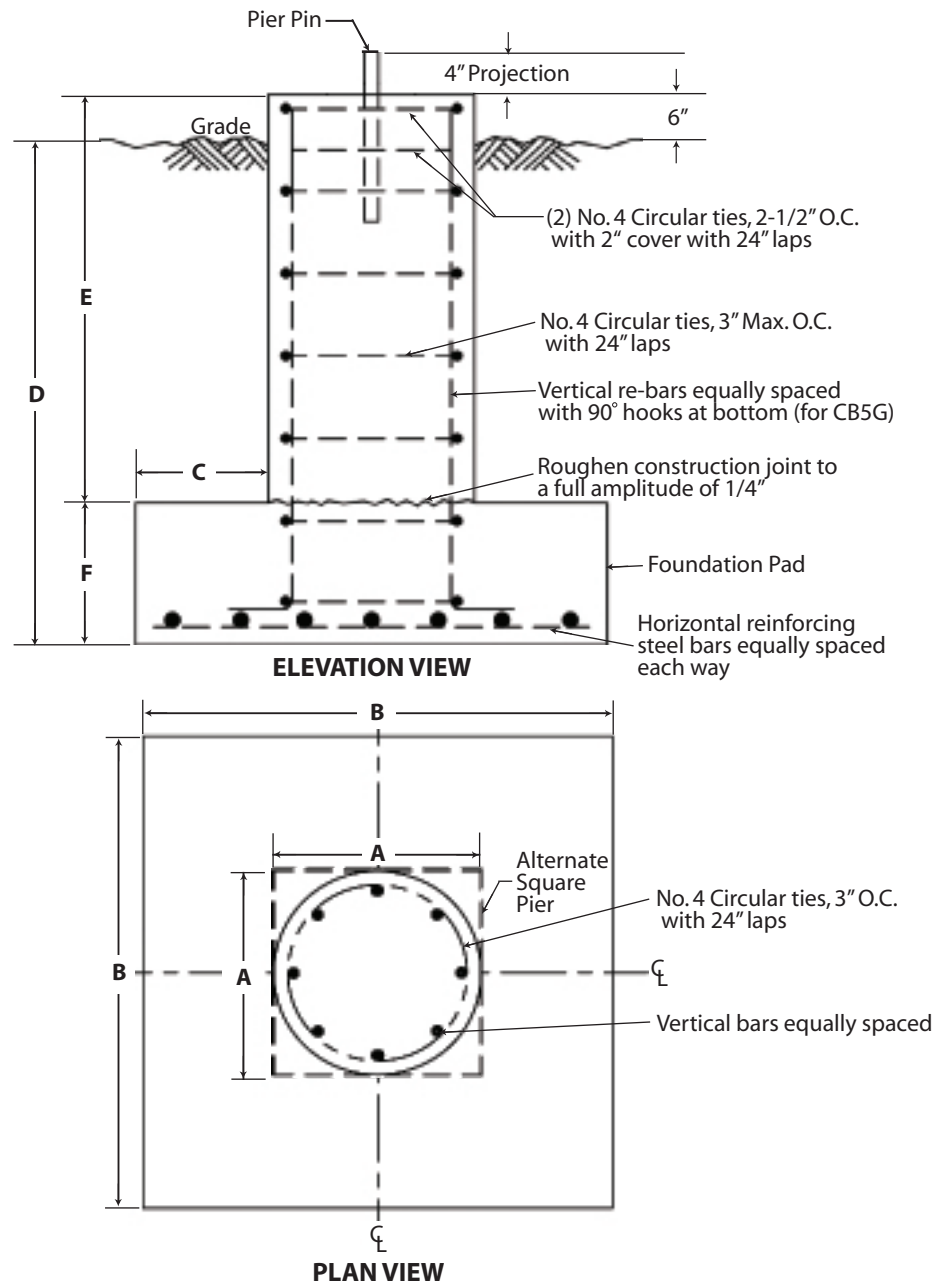

Base	A	B	C	D	E	F	Concrete Vol. (Cu. Yds.) Round Pier	Vertical Bars (No. & Size)	Horiz. Bars in Pad (No. & Size)
CB1G*	2' - 6"	2' - 6"	N/A	4' - 0"	N/A	N/A	1.0	(8) #7	NONE
CB2G	3' - 0"	3' - 0"	N/A	4' - 0"	N/A	N/A	1.2	(10) #7	NONE
CB3G	3' - 6"	3' - 6"	N/A	4' - 0"	N/A	N/A	1.6	(12) #7	NONE
CB4G	4' - 0"	4' - 0"	N/A	4' - 0"	N/A	N/A	2.1	(12) #8	NONE
CB5G	2' - 0"	4' - 0"	1' - 0"	4' - 0"	3' - 3"	1' - 3"	1.1	(8) #6	(5) #5 (Total of 10)

* Square pier option must be used for CB1G.

NOTES





STANDARD 65G GUYED TOWER

ROHN 65G
The first. The original.



65G



GENERAL USE

The 65G is designed to provide excellent rigidity and strength in applications up to 500'. This high strength design covers a wide variety of communication uses. The 65G is completely pre-fabricated in welded sections, allowing for quick and convenient installation.

FEATURES

- Completely hot-dip galvanized after fabrication
- Built on a 24 1/4" equilateral triangle design
- High strength tubular legs joined by Zig-Zag® cross members
- Each section contains all required nuts and bolts shipped with section
- Continuous solid round steel bracing

CAUTION

Mixing copies of ROHN towers with ROHN towers is dangerous and voids all engineering and warranty data supplied by ROHN. Materials used by others are not the same quality and have not been tested or engineered by ROHN. Mixing ROHN tower sections with non-ROHN products may cause tower failure or injury.

Per Rev G requirements, any structure greater than 10' requires a climber safety device. Please see page 142 for ordering information.



STANDARD 65G GUYED TOWER SECTIONS

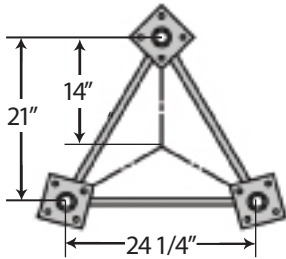

QUICK REFERENCE

PARTS & ACCESSORIES	PAGES 141-142
GROUNDING INFORMATION	PAGE 143
FOUNDATION INFORMATION	PAGES 143-146

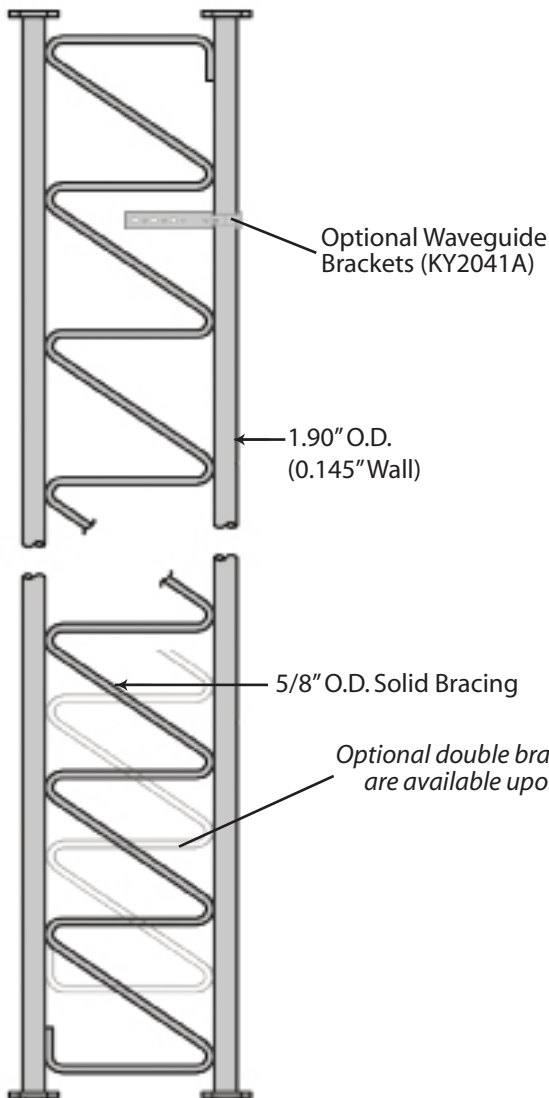

STANDARD SECTION
65G - 10' Section
6520G - 20' Section

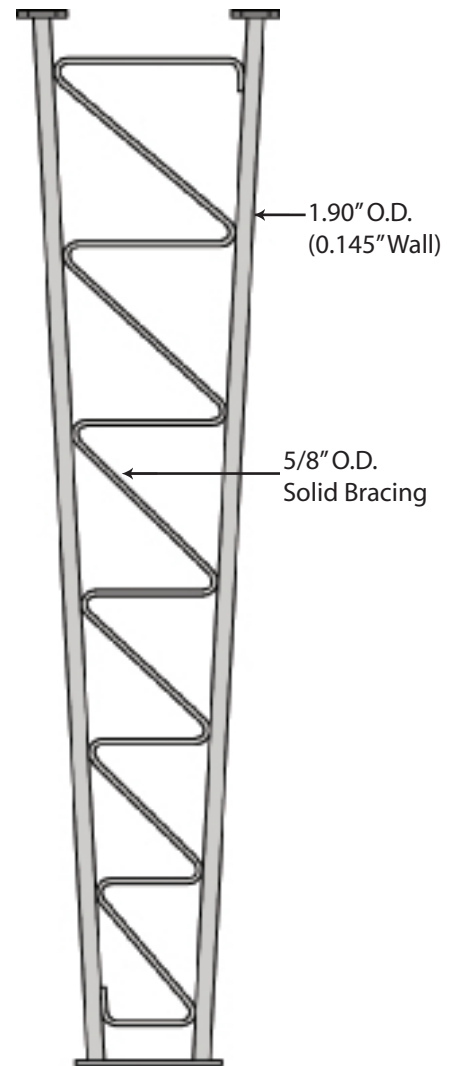

TAPERED BASE
65TGH - 10' Section



BUYERS GUIDE
STANDARD DESIGNS - 65G
90MPH REV. G [3 SECOND GUST]
70MPH REV. F [FASTEST MILE]

Design Criteria

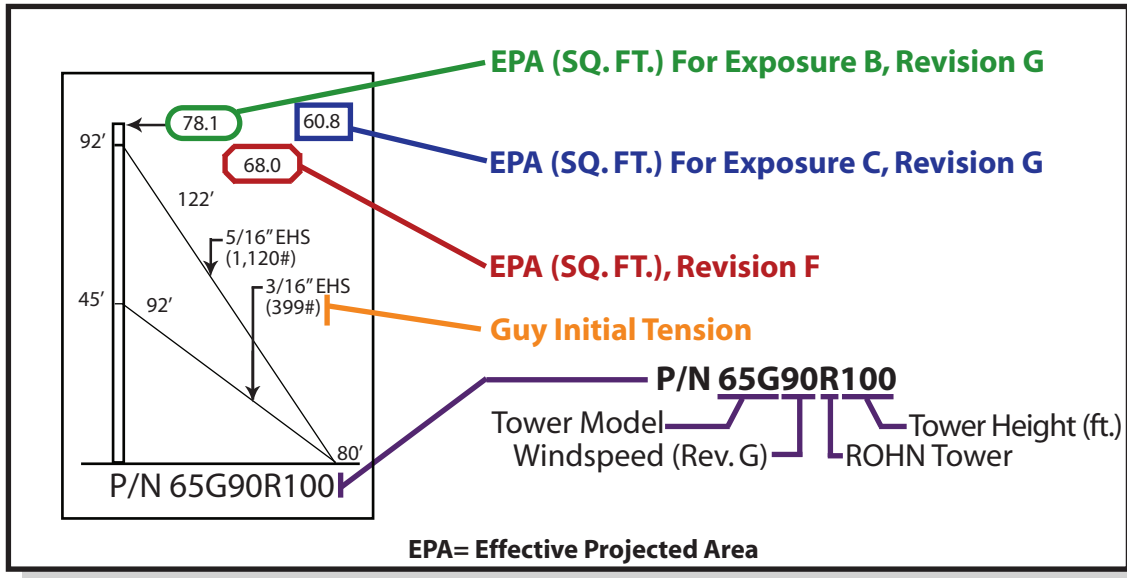

This document is to serve as a guide for sizing and purchasing the 65G tower. Tower and foundation installations should be performed by qualified and experienced personnel using assembly drawings provided with each tower.

DESIGN NOTES:

1. Tower designs are in accordance with ANSI/TIA-222-F and ANSI/TIA-222-G, Class I Structures, Topographic Category 1.
2. Design assumes towers are installed on level ground. Lower EPA values will apply for roof mounted towers or for sites located on unusual terrain.
3. Designs assume two 7/8" diameter lines on each tower face.
4. Anchor radius is from tower base to intersection of anchor rod with ground.
5. Guy chord lengths shown are based on level ground. Initial tensions for guys are shown in () in pounds at 60° Fahrenheit.
6. Antenna and mounts are assumed symmetrically placed at the tower top.

PARTS LIST NOTES:

1. Items listed are required for complete guyed towers.
2. Base and anchor foundations listed refer to standard foundation designations.
3. Guys provided with each standard tower are based on level ground conditions with an additional 6% length.
4. Rev G anchor grounding (AGK1GGX) and base grounding (BGK2GGX) are included with the tower material.
5. Assembly drawings and a safety package (P/N: ACWS) are included with each tower.
6. Parts lists are subject to change based on availability or revised design criteria.

FOR FOUNDATION INFORMATION, PLEASE SEE PAGES 143-146.
FOR GENERAL INSTALLATION INFORMATION, PLEASE SEE PAGES 147-153.



STANDARD DESIGN - 65G

90 MPH REV. G, 70MPH REV. F

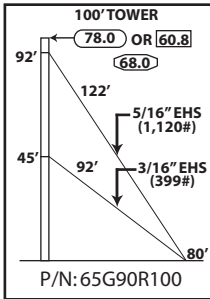

TOWER PARTS INCLUDED	65G	65TGH	6520G	GA65GD	APL4HA	FDNS		
						BASE	ANCHOR	
TOWER PARTS INCLUDED	1	1	4	2	1	CB2G	AB2	
GUYS & CONNECTIONS INCLUDED	142265	3/16EHS	BG2142	BG2146	5/16THH	7/16THH	5/8TBE&J	1/2TBE&J
	400'	300'	6	6	6	6	3	3
ANCHORS & GROUNDING INCLUDED	GAC3455TOP	AGK1GGX	BGK2GGX	CPC.5/.75	TBSAFETY	15/16x16PP		
	3	1	3	3	3	1		

100' ROHN 65G
All parts shown in table are included when ordering Part No: 65G90R100

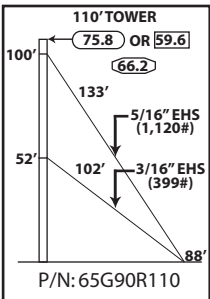

TOWER PARTS INCLUDED	65TGH	6520G	APL4HA	GA65GD	FDNS			
					BASE	ANCHOR		
TOWER PARTS INCLUDED	1	5	1	2	CB2G	AB2		
GUYS & CONNECTIONS INCLUDED	142265	3/16EHS	BG2142	BG2146	5/16THH	7/16THH	5/8TBE&J	1/2TBE&J
	425'	325'	6	6	6	6	3	3
ANCHORS & GROUNDING INCLUDED	GAC3455TOP	AGK1GGX	BGK2GGX	CPC.5/.75	TBSAFETY	15/16x16PP		
	3	1	3	3	3	1		

110' ROHN 65G
All parts shown in table are included when ordering Part No: 65G90R110

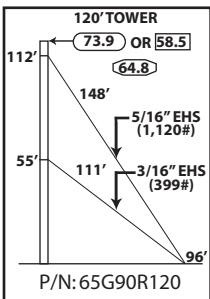

TOWER PARTS INCLUDED	65G	65TGH	6520G	GA65GD	APL4HA	FDNS		
						BASE	ANCHOR	
TOWER PARTS INCLUDED	1	1	5	2	1	CB2G	AB2	
GUYS & CONNECTIONS INCLUDED	142265	3/16EHS	BG2142	BG2146	5/16THH	7/16THH	5/8TBE&J	1/2TBE&J
	475'	375'	6	6	6	6	3	3
ANCHORS & GROUNDING INCLUDED	GAC3455TOP	AGK1GGX	BGK2GGX	CPC.5/.75	TBSAFETY	15/16x16PP		
	3	1	3	3	3	1		

120' ROHN 65G
All parts shown in table are included when ordering Part No: 65G90R120

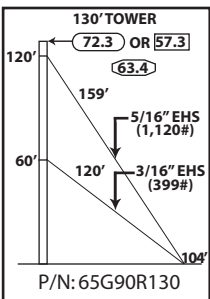

TOWER PARTS INCLUDED	65TGH	6520G	GA65GD	APL4HA	FDNS			
					BASE	ANCHOR		
TOWER PARTS INCLUDED	1	6	2	1	CB2G	AB2		
GUYS & CONNECTIONS INCLUDED	142265	3/16EHS	BG2142	BG2146	5/16THH	7/16THH	5/8TBE&J	1/2TBE&J
	525'	400'	6	6	6	6	3	3
ANCHORS & GROUNDING INCLUDED	GAC3455TOP	AGK1GGX	BGK2GGX	CPC.5/.75	TBSAFETY	15/16x16PP		
	3	1	3	3	3	1		

130' ROHN 65G
All parts shown in table are included when ordering Part No: 65G90R130

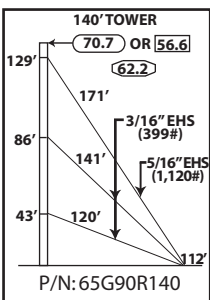

TOWER PARTS INCLUDED	65G	65TGH	6520G	APL4HA	GA65GD	FDNS		
						BASE	ANCHOR	
TOWER PARTS INCLUDED	1	1	6	1	3	CB2G	AB2	
GUYS & CONNECTIONS INCLUDED	142265	3/16EHS	BG2142	BG2146	5/16THH	7/16THH	5/8TBE&J	1/2TBE&J
	550'	850'	12	6	12	6	3	6
ANCHORS & GROUNDING INCLUDED	GAC3455TOP	AGK1GGX	BGK2GGX	CPC.5/.75	TBSAFETY	15/16x16PP		
	3	1	3	3	3	1		

140' ROHN 65G
All parts shown in table are included when ordering Part No: 65G90R140



STANDARD DESIGN - 65G
90MPH REV. G, 70MPH REV. F

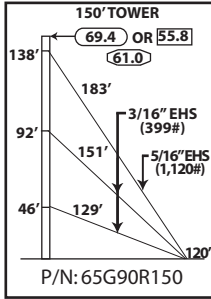

TOWER PARTS INCLUDED	65TGH	6520G	APL4HA	GA65GD	FDNS		1/2TBE&J
					BASE	ANCHOR	
	1	7	1	3	CB2G	AB2	
GUYS & CONNECTIONS INCLUDED	142265	3/16EHS	BG2142	BG2146	5/16THH	7/16THH	5/8TBE&J
	600'	900'	12	6	12	6	3
ANCHORS & GROUNDING INCLUDED	GAC3455TOP	AGK1GGX	BGK2GGX	CPC.5/75	TBSAFETY	15/16x16PP	
	3	1	3	3	3	1	

150' ROHN 65G
All parts shown in table are included when ordering
Part No: 65G90R150

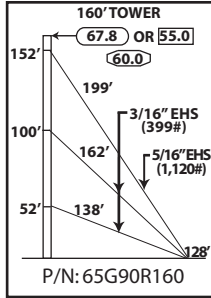

TOWER PARTS INCLUDED	65G	65TGH	6520G	APL4HA	GA65GD	FDNS	
						BASE	ANCHOR
	1	1	7	1	3	CB2G	AB3
GUYS & CONNECTIONS INCLUDED	142265	3/16EHS	BG2142	BG2146	5/16THH	7/16THH	5/8TBE&J
	650'	975'	12	6	12	6	9
ANCHORS & GROUNDING INCLUDED	GAC5655TOP	AGK1GGX	BGK2GGX	CPC1/1.25	TBSAFETY	15/16x16PP	
	3	1	3	3	3	1	

160' ROHN 65G
All parts shown in table are included when ordering
Part No: 65G90R160

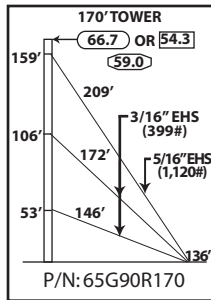

TOWER PARTS INCLUDED	65TGH	6520G	APL4HA	GA65GD	FDNS		5/8TBE&J
					BASE	ANCHOR	
	1	8	1	3	CB3G	AB3	
GUYS & CONNECTIONS INCLUDED	142265	3/16EHS	BG2142	BG2146	5/16THH	7/16THH	5/8TBE&J
	675'	1025'	12	6	12	6	9
ANCHORS & GROUNDING INCLUDED	GAC5655TOP	AGK1GGX	BGK2GGX	CPC1/1.25	TBSAFETY	15/16x16PP	
	3	1	3	3	3	1	

170' ROHN 65G
All parts shown in table are included when ordering
Part No: 65G90R170

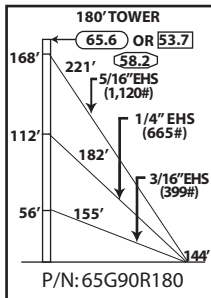

TOWER PARTS INCLUDED	65G	65TGH	6520G	APL4HA	GA65GD	FDNS	
						BASE	ANCHOR
	1	1	8	1	3	CB3G	AB3
GUYS & CONNECTIONS INCLUDED	142265	1/4EHS	3/16EHS	BG2142	BG2144		
	725'	600'	500'	6	6		
	BG2146	5/8TBE&J	7/16THH	3/8THH	5/16THH		
	6	9	6	6	6		
ANCHORS & GROUNDING INCLUDED	GAC5655TOP	AGK1GGX	BGK2GGX	CPC1/1.25	TBSAFETY	15/16x16PP	
	3	1	3	3	3	1	

180' ROHN 65G
All parts shown in table are included when ordering
Part No: 65G90R180



STANDARD DESIGN - 65G 90MPH REV. G, 70MPH REV. F

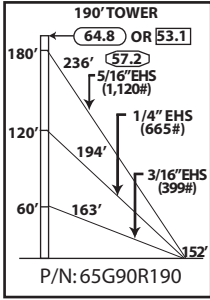

TOWER PARTS INCLUDED	65TGH	6520G	APL4HA	GA65GD	BASE	INNER ANCHOR
	1	9	1	3	CB3G	AB3
GUYS & CONNECTIONS INCLUDED	142265	1/4EHS	3/16EHS	BG2142	BG2144	
	750'	625'	525'	6	6	
	BG2146	5/8TBE&J	7/16THH	3/8THH	5/16THH	
	6	9	6	6	6	
ANCHORS & GROUNDING INCLUDED	GAC5655TOP	AGK1GGX	BGK2GGX	CPC1/1.25	TBSAFETY	15/16x16PP
	3	1	3	6	3	1

190' ROHN 65G
All parts shown in table are included when ordering
Part No: 65G90R190

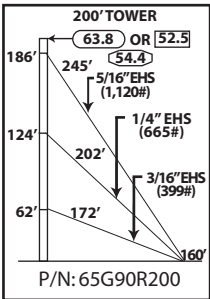

TOWER PARTS INCLUDED	65G	65TGH	6520G	APL4HA	GA65GD	FDNS	
	1	1	9	1	3	BASE	ANCHOR
GUYS & CONNECTIONS INCLUDED	142265	1/4EHS	3/16EHS	BG2142	BG2144		
	800'	650'	550'	6	6		
	BG2146	5/8TBE&J	7/16THH	3/8THH	5/16THH		
	6	9	6	6	6		
ANCHORS & GROUNDING INCLUDED	GAC5655TOP	AGK1GGX	BGK2GGX	CPC1/1.25	TBSAFETY	15/16x16PP	
	3	1	3	3	3	1	

200' ROHN 65G
All parts shown in table are included when ordering
Part No: 65G90R200

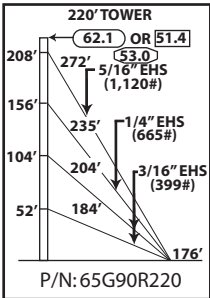

TOWER PARTS INCLUDED	65G	65TGH	6520G	APL4HA	GA65GD	FDNS	
	1	1	10	1	4	BASE	ANCHOR
GUYS & CONNECTIONS INCLUDED	142265	1/4EHS	3/16EHS	BG2142	BG2144		
	875'	750'	1250'	12	6		
	BG2146	5/8TBE&J	7/16THH	3/8THH	5/16THH		
	6	12	6	6	12		
ANCHORS & GROUNDING INCLUDED	GAC5655TOP	AGK1GGX	BGK2GGX	CPC1/1.25	TBSAFETY	15/16x16PP	
	3	1	3	3	3	1	

220' ROHN 65G
All parts shown in table are included when ordering
Part No: 65G90R220

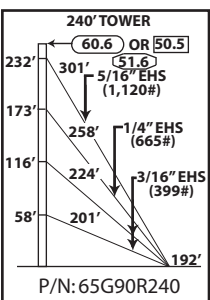

TOWER PARTS INCLUDED	65G	65TGH	6520G	APL4HA	GA65GD	FDNS	
	1	1	11	1	4	BASE	ANCHOR
GUYS & CONNECTIONS INCLUDED	142265	1/4EHS	3/16EHS	BG2142	BG2144		
	975'	825'	1375'	12	6		
	BG2146	5/8TBE&J	7/16THH	3/8THH	5/16THH		
	6	12	6	6	12		
ANCHORS & GROUNDING INCLUDED	GAC5655TOP	AGK1GGX	BGK2GGX	CPC1/1.25	TBSAFETY	15/16x16PP	
	3	1	3	3	3	1	

240' ROHN 65G
All parts shown in table are included when ordering
Part No: 65G90R240



STANDARD DESIGN - 65G
90MPH REV. G, 70MPH REV. F

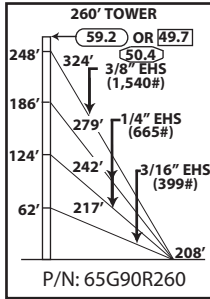

TOWER PARTS INCLUDED	65G	65TGH	6520G	APL4HA	GA65GD	FDNS	
						BASE	ANCHOR
	1	1	12	1	4	CB4G	AB4
GUYS & CONNECTIONS INCLUDED	142261	1/4EHS	3/16EHS	BG2142	BG2144	260' ROHN 65G All parts shown in table are included when ordering Part No: 65G90R260	
	1050'	1675'	700'	6	12		
	BG2147	5/8TBE&J	1/2THH	3/8THH	5/16THH		
	6	12	6	12	6		
ANCHORS & GROUNDING INCLUDED	GAC5655TOP	AGK1GGX	BGK2GGX	CPC1/1.25	TBSAFETY	15/16x16PP	
	3	1	3	3	3	1	

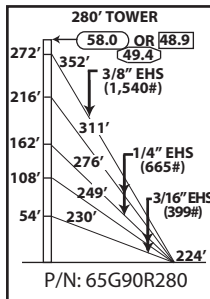

TOWER PARTS INCLUDED	65G	65TGH	6520G	APL4HA	GA65GD	FDNS	
						BASE	ANCHOR
	1	1	13	1	5	CB4G	AB4
GUYS & CONNECTIONS INCLUDED	142261	1/4EHS	3/16EHS	BG2142	BG2144	280' ROHN 65G All parts shown in table are included when ordering Part No: 65G90R280	
	1125'	1875'	1550'	12	12		
	BG2147	5/8TBE&J	1/2THH	3/8THH	5/16THH		
	6	15	6	12	12		
ANCHORS & GROUNDING INCLUDED	GAC5655TOP	AGK1GGX	BGK2GGX	CPC1/1.25	TBSAFETY	15/16x16PP	
	3	1	3	3	3	1	

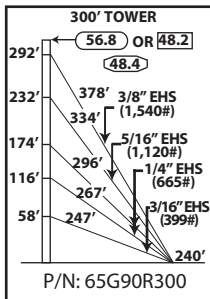

TOWER PARTS INCLUDED	65G	65TGH	6520G	APL4HA	GA65GD	FDNS	
						BASE	ANCHOR
	1	1	14	1	5	CB4G	AB4
GUYS & CONNECTIONS INCLUDED	142261	142265	1/4EHS	3/16EHS	BG2142	300' ROHN 65G All parts shown in table are included when ordering Part No: 65G90R300	
	1225'	1075'	1800'	800'	6		
	BG2144	BG2146	BG2147	5/8TBE&J	1/2THH		
	12	6	6	15	6		
	7/16THH	3/8THH	5/16THH	TBSAFETY			
	6	12	6	3			
ANCHORS & GROUNDING INCLUDED	GAC5655TOP	AGK1GGX	BGK2GGX	CPC1/1.25	15/16x16PP		
	3	1	3	3	1		



STANDARD DESIGN - 65G 90MPH REV.G, 70MPH REV. F

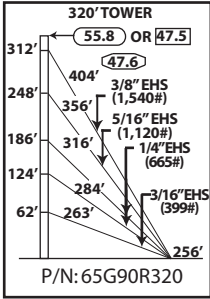

TOWER PARTS INCLUDED	65G	65TGH	6520G	APL4HA	GA65GD	FDNS	
						BASE	ANCHOR
	1	1	15	1	5	CB5G	AB4
GUYS & CONNECTIONS INCLUDED	142261	142265	1/4EHS	3/16EHS	BG2142		
	1300'	1150'	1925'	850'	6		
	BG2144	BG2146	BG2147	5/8TBE&J	1/2THH		
	12	6	6	15	6		
	7/16THH	3/8THH	5/16THH	TBSAFETY			
	6	12	6	3			
ANCHORS & GROUNDING INCLUDED	GAC5655TOP	AGK1GGX	BGK2GGX	CPC1/1.25	15/16x16PP		
	3	1	3	3	1		

320' ROHN 65G
All parts shown in table are included when ordering
Part No: 65G90R320

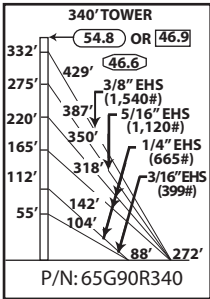

TOWER PARTS INCLUDED	65G	65TGH	6520G	APL4HA	GA65GD	BASE	INNER ANCHOR	OUTER ANCHOR
GUYS & CONNECTIONS INCLUDED	142261	142265	1/4EHS	3/16EHS	BG2142			
	1375'	1250'	2600'	350'	6			
	BG2144	BG2146	BG2147	5/8TBE&J	1/2TBE&J			
	18	6	6	12	6			
	1/2THH	7/16THH	3/8THH	5/16THH				
	6	6	18	6				
ANCHORS & GROUNDING INCLUDED	GAC5655TOP	GAC3455TOP	AGK1GGX	BGK2GGX				
	3	3	2	3				
	CPC.5/1.75	CPC1/1.25	TBSAFETY	15/16x16PP				
	3	3	6	1				

340' ROHN 65G
All parts shown in table are included when ordering
Part No: 65G90R340

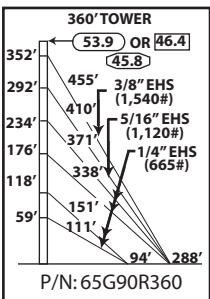

TOWER PARTS INCLUDED	65G	65TGH	6520G	APL4HA	GA65GD	BASE	INNER ANCHOR	OUTER ANCHOR
GUYS & CONNECTIONS INCLUDED	142261	142265	1/4EHS	5/8TBE&J	1/2TBE&J	3/8THH		
	1450'	1325'	3100'	12	6	24		
	BG2144	BG2146	BG2147	1/2THH	7/16THH			
	24	6	6	6	6			
ANCHORS & GROUNDING INCLUDED	GAC5655TOP	GAC3455TOP	AGK1GGX	BGK2GGX	CPC.5/1.75			
	3	3	2	3	3			
	CPC1/1.25	APL1258UM	TBSAFETY	15/16x16PP				
	3	2	6	1				

360' ROHN 65G
All parts shown in table are included when ordering
Part No: 65G90R360



STANDARD DESIGN - 65G
90MPH REV. G, 70MPH REV. F

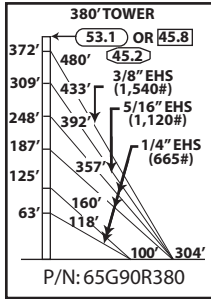

TOWER PARTS INCLUDED	65G	65TGH	6520G	APL4HA	GA65GD	BASE	INNER ANCHOR	OUTER ANCHOR
		1	1	18	1	6	CB6G	AB2
GUYS & CONNECTIONS INCLUDED	142261	142265	1/4EHS	5/8TBE&J	1/2TBE&J	3/8THH		
	1550'	1400'	3300'	12	6	24		
	BG2144	BG2146	BG2147	1/2THH	7/16THH			
	24	6	6	6	6			
ANCHORS & GROUNDING INCLUDED	GAC5655TOP	GAC3455TOP	AGK1GGX	BGK2GGX	CPC.5/1.75			
	3	3	2	3	3			
	CPC1/1.25	APL1258UM	TBSAFETY	15/16x16PP				
	3	2	6	1				

380' ROHN 65G
All parts shown in table are included when ordering
Part No: 65G90R380

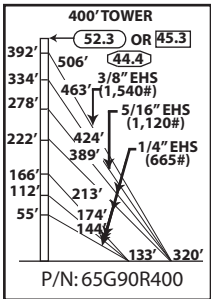

TOWER PARTS INCLUDED	65G	65TGH	6520G	APL4HA	GA65GD	BASE	INNER ANCHOR	OUTER ANCHOR
		1	1	19	1	7	CB6G	AB2
GUYS & CONNECTIONS INCLUDED	142261	142265	1/4EHS	5/8TBE&J	1/2TBE&J	3/8THH		
	1625'	1475'	4300'	12	9	30		
	BG2144	BG2146	BG2147	1/2THH	7/16THH			
	30	6	6	6	6			
ANCHORS & GROUNDING INCLUDED	GAC5655TOP	GAC3455TOP	AGK1GGX	BGK2GGX	CPC.5/1.75			
	3	3	2	3	3			
	CPC1/1.25	APL1258UM	TBSAFETY	15/16x16PP				
	3	2	6	1				

400' ROHN 65G
All parts shown in table are included when ordering
Part No: 65G90R400

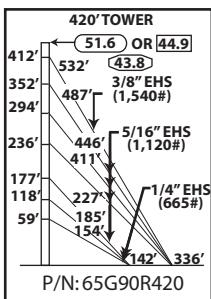

TOWER PARTS INCLUDED	65G	65TGH	6520G	APL4HA	GA65GD	BASE	INNER ANCHOR	OUTER ANCHOR
		1	1	20	1	7	CB6G	AB3
GUYS & CONNECTIONS INCLUDED	142261	142265	1/4EHS	5/8TBE&J	3/8THH			
	1700'	5025'	1100'	21	12			
	BG2144	BG2146	BG2147	1/2THH	7/16THH			
	12	24	6	6	24			
ANCHORS & GROUNDING INCLUDED	GAC5655TOP	APL1258UM	AGK1GGX	BGK2GGX	CPC1/1.25			
	6	2	2	3	6			
	TBSAFETY	15/16x16PP						
	6	1						

420' ROHN 65G
All parts shown in table are included when ordering
Part No: 65G90R420



STANDARD DESIGN - 65G

90 MPH REV. G, 70MPH REV. F

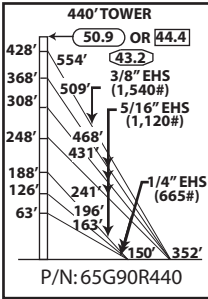

TOWER PARTS INCLUDED	65G	65TGH	6520G	APL4HA	GA65GD	BASE	INNER ANCHOR	OUTER ANCHOR
		1	1	21	1	7	CB7G	AB3
GUYS & CONNECTIONS INCLUDED	142261	142265	1/4EHS	5/8TBE&J	3/8THH			
	1775'	5275'	1150'	21	12			
	BG2144	BG2146	BG2147	1/2THH	7/16THH			
	12	24	6	6	24			
ANCHORS & GROUNDING INCLUDED	GAC5655TOP	APL1258UM	AGK1GGX	BGK2GGX	CPC1/1.25			
	6	2	2	3	6			
	TBSAFETY	15/16x16PP						
	6	1						

440' ROHN 65G
All parts shown in table are included when ordering
Part No: 65G90R440

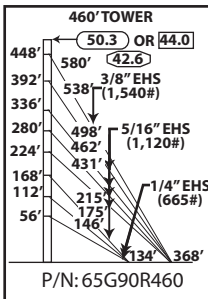

TOWER PARTS INCLUDED	65G	65TGH	6520G	APL4HA	GA65GD	BASE	INNER ANCHOR	OUTER ANCHOR
		1	1	22	1	8	CB7G	AB3
GUYS & CONNECTIONS INCLUDED	142261	142265	1/4EHS	3/4TBE&J	5/8TBE&J	3/8THH		
	1850'	6850'	1025'	15	9	12		
	BG2144	BG2146	BG2147	1/2THH	7/16THH			
	12	30	6	6	30			
ANCHORS & GROUNDING INCLUDED	GAC5655TOP	GAC5755TOP	AGK1GGX	BGK2GGX	CPC1/1.25			
	3	3	2	3	3			
	CPC1.5/2	APL1258UM	TBSAFETY	15/16x16PP				
	3	2	6	1				

460' ROHN 65G
All parts shown in table are included when ordering
Part No: 65G90R460

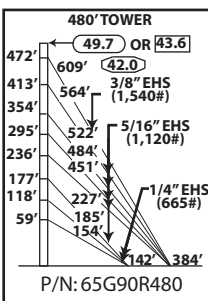

TOWER PARTS INCLUDED	65G	65TGH	6520G	APL4HA	GA65GD	BASE	INNER ANCHOR	OUTER ANCHOR
		1	1	23	1	8	CB7G	AB3
GUYS & CONNECTIONS INCLUDED	142261	142265	1/4EHS	3/4TBE&J	5/8TBE&J	3/8THH		
	1950'	7175'	1100'	15	9	12		
	BG2144	BG2146	BG2147	1/2THH	7/16THH			
	12	30	6	6	30			
ANCHORS & GROUNDING INCLUDED	GAC5655TOP	GAC5755TOP	AGK1GGX	BGK2GGX	CPC1/1.25			
	3	3	2	3	3			
	CPC1.5/2	APL1258UM	TBSAFETY	15/16x16PP				
	3	2	6	1				

480' ROHN 65G
All parts shown in table are included when ordering
Part No: 65G90R480



STANDARD DESIGN - 65G
90MPH REV. G, 70MPH REV. F

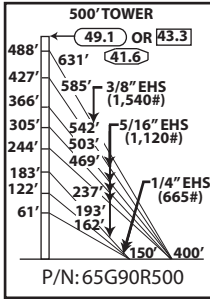

TOWER PARTS INCLUDED	65G	65TGH	6520G	APL4HA	GA65GD	BASE	INNER ANCHOR	OUTER ANCHOR
		1	1	24	1	8	CB7G	AB3
GUYS & CONNECTIONS INCLUDED	142261	142265	1/4EHS	3/4TBE&J	5/8TBE&J	3/8THH		
	2025'	7450'	1150'	15	9	12		
	BG2144	BG2146	BG2147	1/2THH	7/16THH			
	12	30	6	6	30			
ANCHORS & GROUNDING INCLUDED	GAC5655TOP	GAC5755TOP	AGK1GGX	BGK2GGX	CPC1/1.25			
	3	3	2	3	3			
	CPC1.5/2	APL1258UM	TBSAFETY	15/16x16PP				
	3	2	6	1				

500' ROHN 65G
All parts shown in table are included when ordering
Part No: 65G90R500



STANDARD DESIGN - 65G
110 MPH REV. G, 90MPH REV. F

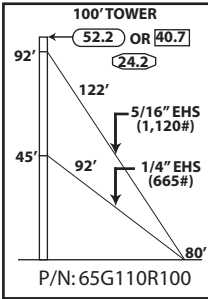

TOWER PARTS INCLUDED	65G	65TGH	6520G	APL4HA	GA65GD	FDNS		
						BASE	ANCHOR	
TOWER PARTS INCLUDED	1	1	4	1	2	CB2G	AB2	
GUYS & CONNECTIONS INCLUDED	142265	1/4EHS	BG2144	BG2146	7/16THH	3/8THH	5/8TBE&J	1/2TBE&J
	400'	300'	6	6	6	6	3	3
ANCHORS & GROUNDING INCLUDED	GAC3455TOP	AGK1GGX	BGK2GGX	CPC.5/.75	TBSAFETY	15/16x16PP		
	3	1	3	3	3	1		

100' ROHN 65G
All parts shown in table are included when ordering
Part No: 65G110R100

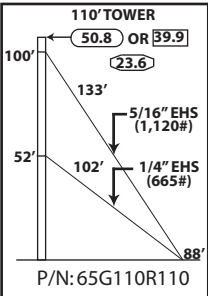

TOWER PARTS INCLUDED	65TGH	6520G	APL4HA	GA65GD	FDNS			
					BASE	ANCHOR		
TOWER PARTS INCLUDED	1	5	1	2	CB2G	AB2		
GUYS & CONNECTIONS INCLUDED	142265	1/4EHS	BG2144	BG2146	7/16THH	3/8THH	5/8TBE&J	1/2TBE&J
	425'	325'	6	6	6	6	3	3
ANCHORS & GROUNDING INCLUDED	GAC3455TOP	AGK1GGX	BGK2GGX	CPC.5/.75	TBSAFETY	15/16x16PP		
	3	1	3	3	3	1		

110' ROHN 65G
All parts shown in table are included when ordering
Part No: 65G110R110

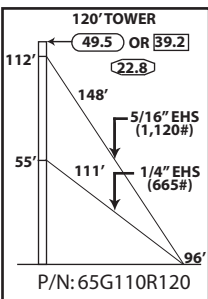

TOWER PARTS INCLUDED	65G	65TGH	6520G	APL4HA	GA65GD	FDNS	
						BASE	ANCHOR
TOWER PARTS INCLUDED	1	1	5	1	2	CB2G	AB3
GUYS & CONNECTIONS INCLUDED	142265	1/4EHS	BG2144	BG2146	7/16THH	3/8THH	5/8TBE&J
	475'	375'	6	6	6	6	6
ANCHORS & GROUNDING INCLUDED	GAC5655TOP	AGK1GGX	BGK2GGX	CPC1/1.25	TBSAFETY	15/16x16PP	
	3	1	3	3	3	1	

120' ROHN 65G
All parts shown in table are included when ordering
Part No: 65G110R120

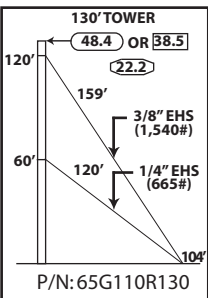

TOWER PARTS INCLUDED	65TGH	6520G	APL4HA	GA65GD	FDNS		
					BASE	ANCHOR	
TOWER PARTS INCLUDED	1	6	1	2	CB2G	AB3	
GUYS & CONNECTIONS INCLUDED	142261	1/4EHS	BG2147	BG2144	1/2THH	3/8THH	5/8TBE&J
	525'	400'	6	6	6	6	6
ANCHORS & GROUNDING INCLUDED	GAC5655TOP	AGK1GGX	BGK2GGX	CPC1/1.25	TBSAFETY	15/16x16PP	
	3	1	3	3	3	1	

130' ROHN 65G
All parts shown in table are included when ordering
Part No: 65G110R130

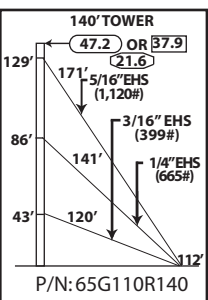

TOWER PARTS INCLUDED	65G	65TGH	6520G	APL4HA	GA65GD	FDNS	
						BASE	ANCHOR
TOWER PARTS INCLUDED	1	1	6	1	3	CB3G	AB3
GUYS & CONNECTIONS INCLUDED	142265	1/4EHS	3/16EHS	BG2142	BG2144		
	550'	450'	400'	6	6		
	BG2146	5/8TBE&J	7/16THH	3/8THH	5/16THH		
	6	9	6	6	6		
ANCHORS & GROUNDING INCLUDED	GAC5655TOP	AGK1GGX	BGK2GGX	CPC1/1.25	TBSAFETY	15/16x16PP	
	3	1	3	3	3	1	

140' ROHN 65G
All parts shown in table are included when ordering
Part No: 65G110R140



STANDARD DESIGN - 65G
110MPH REV. G, 90MPH REV. F

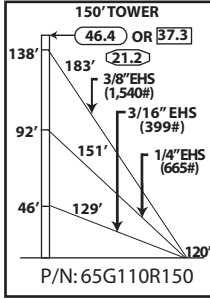

TOWER PARTS INCLUDED	65TGH	6520G	APL4HA	GA65GD	FDNS	
					BASE	ANCHOR
	1	7	1	3	CB3G	AB3
GUYS & CONNECTIONS INCLUDED	142261	1/4EHS	3/16EHS	BG2142	BG2144	
	600'	500'	425'	6	6	
	BG2147	5/8TBE&J	1/2THH	3/8THH	5/16THH	
	6	9	6	6	6	
ANCHORS & GROUNDING INCLUDED	GAC5655TOP	AGK1GGX	BGK2GGX	CPC1/1.25	TBSAFETY	15/16x16PP
	3	1	3	6	3	1

150' ROHN 65G
All parts shown in table are included when ordering
Part No: 65G110R150

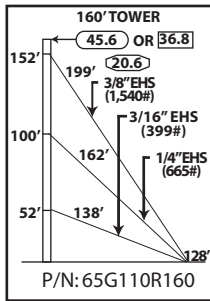

TOWER PARTS INCLUDED	65G	65TGH	6520G	APL4HA	GA65GD	FDNS	
						BASE	ANCHOR
	1	1	7	1	3	CB3G	AB3
GUYS & CONNECTIONS INCLUDED	142261	1/4EHS	3/16EHS	BG2142	BG2144		
	650'	525'	450'	6	6		
	BG2147	5/8TBE&J	1/2THH	3/8THH	5/16THH		
	6	9	6	6	6		
ANCHORS & GROUNDING INCLUDED	GAC5655TOP	AGK1GGX	BGK2GGX	CPC1/1.25	TBSAFETY	15/16x16PP	
	3	1	3	3	3	1	

160' ROHN 65G
All parts shown in table are included when ordering
Part No: 65G110R160

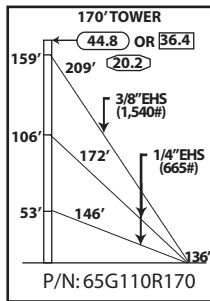

TOWER PARTS INCLUDED	65TGH	6520G	APL4HA	GA65GD	FDNS		
					BASE	ANCHOR	
	1	8	1	3	CB3G	AB3	
GUYS & CONNECTIONS INCLUDED	142261	1/4EHS	BG2144	BG2147	1/2THH	3/8THH	5/8TBE&J
	675'	1025'	12	6	6	12	9
ANCHORS & GROUNDING INCLUDED	GAC5655TOP	AGK1GGX	BGK2GGX	CPC1/1.25	TBSAFETY	15/16x16PP	
	3	1	3	3	3	1	

170' ROHN 65G
All parts shown in table are included when ordering
Part No: 65G110R170

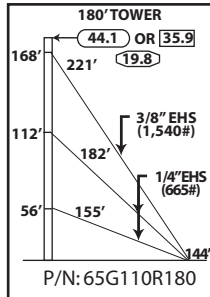

TOWER PARTS INCLUDED	65G	65TGH	6520G	APL4HA	GA65GD	FDNS	
						BASE	ANCHOR
	1	1	8	1	3	CB3G	AB3
GUYS & CONNECTIONS INCLUDED	142261	1/4EHS	BG2144	BG2147	1/2THH	3/8THH	5/8TBE&J
	725'	1075'	12	6	6	12	9
ANCHORS & GROUNDING INCLUDED	GAC5655TOP	AGK1GGX	BGK2GGX	CPC1/1.25	TBSAFETY	15/16x16PP	
	3	1	3	3	3	1	

180' ROHN65G
All parts shown in table are included when ordering
Part No: 65G110R180



STANDARD DESIGN - 65G
110MPH REV. G, 90MPH REV. F

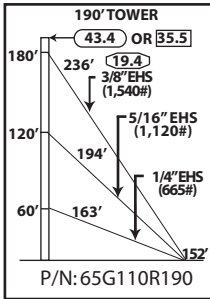

TOWER PARTS INCLUDED	65TGH	6520G	APL4HA	GA65GD	FDNS	
					BASE	ANCHOR
	1	9	1	3	CB4G	AB4
GUYS & CONNECTIONS INCLUDED	142261	142265	1/4EHS	BG2144	BG2146	
	750'	625'	525'	6	6	
	BG2147	5/8TBE&J	1/2THH	7/16THH	3/8THH	
	6	9	6	6	6	
ANCHORS & GROUNDING INCLUDED	GAC565TOP	AGK1GGX	BGK2GGX	CPC1/1.25	TBSAFETY	15/16x16PP
	3	1	3	6	3	1

190' ROHN 65G
All parts shown in table are included when ordering
Part No: 65G110R190

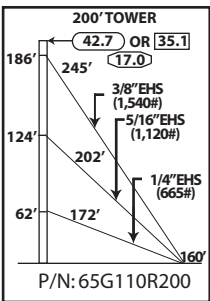

TOWER PARTS INCLUDED	65G	65TGH	6520G	APL4HA	GA65GD	FDNS	
						BASE	ANCHOR
	1	1	9	1	3	CB4G	AB4
GUYS & CONNECTIONS INCLUDED	142261	142265	1/4EHS	BG2144	BG2146		
	800'	650'	550'	6	6		
	BG2147	5/8TBE&J	1/2THH	7/16THH	3/8THH		
	6	9	6	6	6		
ANCHORS & GROUNDING INCLUDED	GAC565TOP	AGK1GGX	BGK2GGX	CPC1/1.25	TBSAFETY	15/16x16PP	
	3	1	3	3	3	1	

200' ROHN 65G
All parts shown in table are included when ordering
Part No: 65G110R200

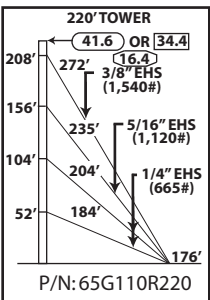

TOWER PARTS INCLUDED	65G	65TGH	6520G	APL4HA	GA65GD	FDNS	
						BASE	ANCHOR
	1	1	10	1	4	CB4G	AB4
GUYS & CONNECTIONS INCLUDED	142261	142265	1/4EHS	BG2144	BG2146		
	875'	750'	1250'	12	6		
	BG2147	5/8TBE&J	1/2THH	7/16THH	3/8THH		
	6	12	6	6	12		
ANCHORS & GROUNDING INCLUDED	GAC565TOP	AGK1GGX	BGK2GGX	CPC1/1.25	TBSAFETY	15/16x16PP	
	3	1	3	3	3	1	

220' ROHN 65G
All parts shown in table are included when ordering
Part No: 65G110R220

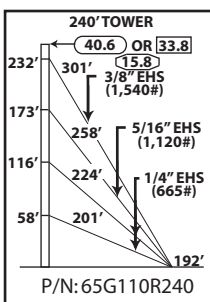

TOWER PARTS INCLUDED	65G	65TGH	6520G	APL4HA	GA65GD	FDNS	
						BASE	ANCHOR
	1	1	11	1	4	CB4G	AB4
GUYS & CONNECTIONS INCLUDED	142261	142265	1/4EHS	BG2144	BG2146		
	975'	825'	1375'	12	6		
	BG2147	5/8TBE&J	1/2THH	7/16THH	3/8THH		
	6	12	6	6	12		
ANCHORS & GROUNDING INCLUDED	GAC565TOP	AGK1GGX	BGK2GGX	CPC1/1.25	TBSAFETY	15/16x16PP	
	3	1	3	3	3	1	

240' ROHN 65G
All parts shown in table are included when ordering
Part No: 65G110R240



STANDARD DESIGN - 65G
110MPH REV. G, 90MPH REV. F

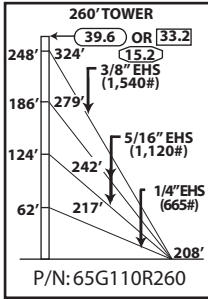

TOWER PARTS INCLUDED	65G	65TGH	6520G	APL4HA	GA65GD	FDNS	
						BASE	ANCHOR
	1	1	12	1	4	CB5G	AB5
GUYS & CONNECTIONS INCLUDED	142261	142265	1/4EHS	BG2144	1/2THH	260' ROHN 65G All parts shown in table are included when ordering Part No: 65G110R260	
	1050'	1675'	700'	6	6		
	7/16THH	3/4TBE&J	3/8THH	BG2146	BG2147		
	12	12	6	12	6		
ANCHORS & GROUNDING INCLUDED	GAC5755TOP	AGK1GGX	BGK2GGX	CPC1.5/2	TBSAFETY	15/16x16PP	
	3	1	3	3	3	1	

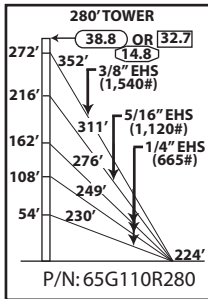

TOWER PARTS INCLUDED	65G	65TGH	6520G	APL4HA	GA65GD	FDNS	
						BASE	ANCHOR
	1	1	13	1	5	CB5G	AB5
GUYS & CONNECTIONS INCLUDED	142261	142265	1/4EHS	BG2144	BG2146	280' ROHN 65G All parts shown in table are included when ordering Part No: 65G110R280	
	1125'	1000'	2450'	18	6		
	BG2147	7/16THH	3/4TBE&J	3/8THH	1/2THH		
	6	6	15	18	6		
ANCHORS & GROUNDING INCLUDED	GAC5755TOP	AGK1GGX	BGK2GGX	CPC1.5/2	TBSAFETY	15/16x16PP	
	3	1	3	6	3	1	

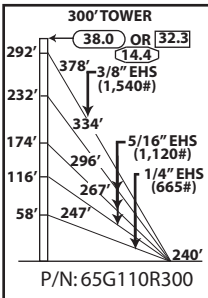

TOWER PARTS INCLUDED	65G	65TGH	6520G	APL4HA	GA65GD	FDNS	
						BASE	ANCHOR
	1	1	14	1	5	CB5G	AB5
GUYS & CONNECTIONS INCLUDED	142261	142265	1/4EHS	BG2144	BG2146	300' ROHN 65G All parts shown in table are included when ordering Part No: 65G110R300	
	1225'	2875'	800'	6	18		
	BG2147	3/4TBE&J	1/2THH	7/16THH	3/8THH		
	6	15	6	18	6		
ANCHORS & GROUNDING INCLUDED	GAC5755TOP	AGK1GGX	BGK2GGX	CPC1.5/2	TBSAFETY	15/16x16PP	
	3	1	3	3	3	1	

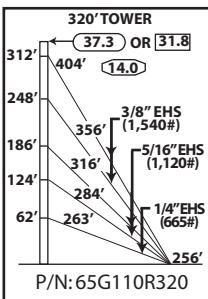

TOWER PARTS INCLUDED	65G	65TGH	6520G	APL4HA	GA65GD	FDNS	
						BASE	ANCHOR
	1	1	15	1	5	CB6G	AB6
GUYS & CONNECTIONS INCLUDED	142261	142265	1/4EHS	BG2144	BG2146	320' ROHN 65G All parts shown in table are included when ordering Part No: 65G110R320	
	2425'	1925'	850'	6	12		
	BG2147	3/4TBE&J	1/2THH	7/16THH	3/8THH		
	12	15	12	12	6		
ANCHORS & GROUNDING INCLUDED	GAC5755TOP	AGK1GGX	BGK2GGX	CPC1.5/2	TBSAFETY	15/16x16PP	
	3	1	3	3	3	1	



STANDARD DESIGN - 65G
110 MPH REV. G, 90MPH REV. F

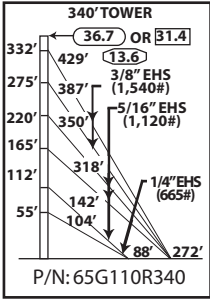

TOWER PARTS INCLUDED	65G	65TGH	6520G	APL4HA	GA65GD	BASE	INNER ANCHOR	OUTER ANCHOR
		1	1	16	1	6	CB7G	AB3
GUYS & CONNECTIONS INCLUDED	142261	142265	1/4EHS	BG2144	BG2146	BG2147		
	2600'	2600'	350'	6	18	12		
	3/4TBE&J	5/8TBE&J	1/2THH	7/16THH	3/8THH			
	12	6	12	18	6			
ANCHORS & GROUNDING INCLUDED	GAC565TOP	GAC575TOP	AGK1GGX	BGK2GGX				
	3	3	2	3				
	CPC1/1.25	CPC1.5/2	TBSAFETY	15/16x16PP				
	3	3	6	1				

340' ROHN 65G
All parts shown in table are included when ordering
Part No: 65G110R340



STANDARD DESIGN - 65G
130 MPH REV. G, 110MPH REV. F

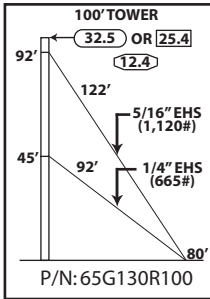

TOWER PARTS INCLUDED	65G	65GTH	6520G	GA65GD	APL4HA	FDNS	
						BASE	ANCHOR
	1	1	4	2	1	CB2G	AB3
GUYS & CONNECTIONS INCLUDED	142265	1/4EHS	BG2146	BG2144	5/8TBE&J	3/8THH	7/16THH
	400'	300'	6	6	6	6	6
ANCHORS & GROUNDING INCLUDED	GAC5655TOP	AGK1GGX	BGK2GGX	CPC1/1.25	TBSAFETY	15/16x16PP	
	3	1	3	3	3	1	

100' ROHN 65G
All parts shown in table are included when ordering
Part No: 65G130R100

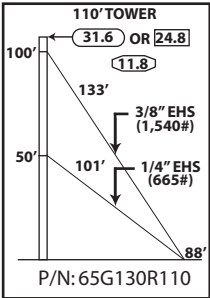

TOWER PARTS INCLUDED	65TGH	6520G	APL4HA	GA65GD	FDNS		
					BASE	ANCHOR	
	1	5	1	2	CB2G	AB3	
GUYS & CONNECTIONS INCLUDED	142261	1/4EHS	BG2147	BG2144	1/2THH	3/8THH	5/8TBE&J
	425'	325'	6	6	6	6	6
ANCHORS & GROUNDING INCLUDED	GAC5655TOP	AGK1GGX	BGK2GGX	CPC1/1.25	TBSAFETY	15/16x16PP	
	3	1	3	3	3	1	

110' ROHN 65G
All parts shown in table are included when ordering
Part No: 65G130R110

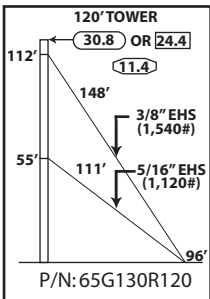

TOWER PARTS INCLUDED	65G	65TGH	6520G	APL4HA	GA65GD	FDNS	
						BASE	ANCHOR
	1	1	5	1	2	CB3G	AB3
GUYS & CONNECTIONS INCLUDED	142261	142265	BG2147	BG2146	7/16THH	1/2THH	5/8TBE&J
	475'	375'	6	6	6	6	6
ANCHORS & GROUNDING INCLUDED	GAC5655TOP	AGK1GGX	BGK2GGX	CPC1/1.25	TBSAFETY	15/16x16PP	
	3	1	3	3	3	1	

120' ROHN 65G
All parts shown in table are included when ordering
Part No: 65G130R120

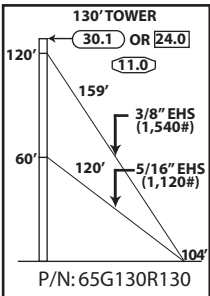

TOWER PARTS INCLUDED	65TGH	6520G	APL4HA	GA65GD	FDNS		
					BASE	ANCHOR	
	1	6	1	2	CB3G	AB3	
GUYS & CONNECTIONS INCLUDED	142261	142265	BG2147	BG2146	7/16THH	1/2THH	5/8TBE&J
	525'	400'	6	6	6	6	6
ANCHORS & GROUNDING INCLUDED	GAC5655TOP	AGK1GGX	BGK2GGX	CPC1/1.25	TBSAFETY	15/16x16PP	
	3	1	3	3	3	1	

130' ROHN 65G
All parts shown in table are included when ordering
Part No: 65G130R130

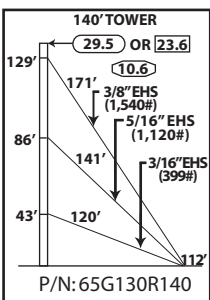

TOWER PARTS INCLUDED	65G	65TGH	6520G	APL4HA	GA65GD	FDNS	
						BASE	ANCHOR
	1	1	6	1	3	CB3G	AB3
GUYS & CONNECTIONS INCLUDED	142261	142265	3/16EHS	BG2147	BG2146		
	550'	450'	400'	6	6		
	BG2142	5/8TBE&J	1/2THH	7/16THH	5/16THH		
	6	9	6	6	6		
ANCHORS & GROUNDING INCLUDED	GAC5655TOP	AGK1GGX	BGK2GGX	CPC1/1.25	TBSAFETY	15/16x16PP	
	3	1	3	3	3	1	

140' ROHN 65G
All parts shown in table are included when ordering
Part No: 65G130R140



STANDARD DESIGN - 65G

130MPH REV. G, 110MPH REV. F

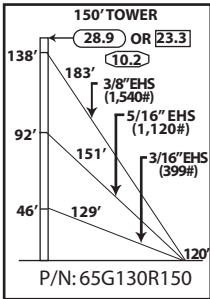

TOWER PARTS INCLUDED	65TGH	6520G	APL4HA	GA65GD	FDNS	
					BASE	ANCHOR
	1	7	1	3	CB3G	AB4
GUYS & CONNECTIONS INCLUDED	142261	142265	3/16EHS	BG2147	BG2146	
	600'	500'	425'	6	6	
	BG2142	5/8TBE&J	1/2THH	7/16THH	5/16THH	
	6	9	6	6	6	
ANCHORS & GROUNDING INCLUDED	GAC5655TOP	AGK1GGX	BGK2GGX	CPC1/1.25	TBSAFETY	15/16x16PP
	3	1	3	3	3	1

150' ROHN 65G
All parts shown in table are included when ordering
Part No: 65G130R150

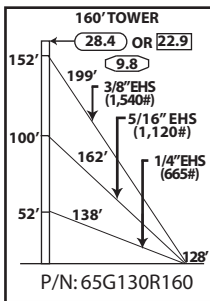

TOWER PARTS INCLUDED	65G	65TGH	6520G	APL4HA	GA65GD	FDNS	
						BASE	ANCHOR
	1	1	7	1	3	CB4G	AB4
GUYS & CONNECTIONS INCLUDED	142261	142265	1/4EHS	BG2147	BG2146		
	650'	525'	450'	6	6		
	BG2144	5/8TBE&J	1/2THH	7/16THH	3/8THH		
	6	9	6	6	6		
ANCHORS & GROUNDING INCLUDED	GAC5655TOP	AGK1GGX	BGK2GGX	CPC1/1.25	TBSAFETY	15/16x16PP	
	3	1	3	3	3	1	

160' ROHN 65G
All parts shown in table are included when ordering
Part No: 65G130R160

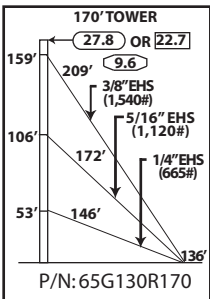

TOWER PARTS INCLUDED	65TGH	6520G	APL4HA	GA65GD	FDNS	
					BASE	ANCHOR
	1	8	1	3	CB4G	AB4
GUYS & CONNECTIONS INCLUDED	142261	142265	1/4EHS	BG2147	BG2146	
	675'	550'	475'	6	6	
	BG2144	5/8TBE&J	1/2THH	7/16THH	3/8THH	
	6	9	6	6	6	
ANCHORS & GROUNDING INCLUDED	GAC5655TOP	AGK1GGX	BGK2GGX	CPC1/1.25	TBSAFETY	15/16x16PP
	3	1	3	3	3	1

170' ROHN 65G
All parts shown in table are included when ordering
Part No: 65G130R170

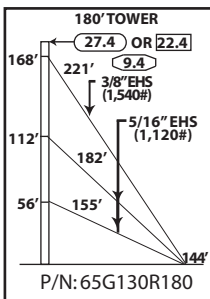

TOWER PARTS INCLUDED	65G	65TGH	6520G	APL4HA	GA65GD	FDNS	
						BASE	ANCHOR
	1	1	8	1	3	CB4G	AB4
GUYS & CONNECTIONS INCLUDED	142261	142265	BG2147	BG2146			
	725'	1075'	6	12			
	5/8TBE&J	1/2THH	7/16THH	TBSAFETY			
	9	6	12	3			
ANCHORS & GROUNDING INCLUDED	GAC5655TOP	AGK1GGX	BGK2GGX	CPC1/1.25	15/16x16PP		
	3	1	3	3	1		

180' ROHN 65G
All parts shown in table are included when ordering
Part No: 65G90R180



STANDARD DESIGN - 65G
130 MPH REV. G, 110MPH REV. F

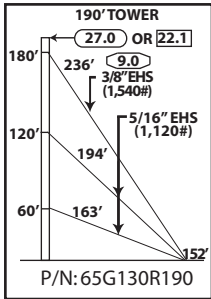
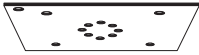
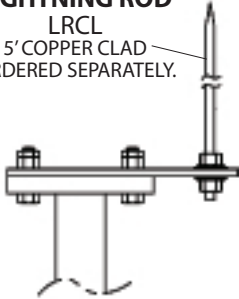





Table with 7 columns: Tower Parts Included, 65TGH, 6520G, APL4HA, GA65GD, FDNS (BASE, ANCHOR), and Guys & Connections Included. It lists quantities for various components like 142261, 142265, BG2147, BG2146, 7/16THH, 1/2THH, 5/8TB&J, GAC5655TOP, AGK1GGX, BGK2GGX, CPC1/1.25, TBSAFETY, and 15/16x16PP.

190' ROHN 65G
All parts shown in table are included when ordering
Part No: 65G130R190



PARTS & ACCESSORIES

 <p>LEG MOUNTED BEACON PLATE KIT APL4HA FOR MOUNTING BEACON OR LIGHTNING ROD. BOLTS TO TOP OF STANDARD SECTION. INCLUDES BEACON PLATE, (2) CAP PLATES, NUTS AND BOLTS.</p>	 <p>LIGHTNING ROD LRCL 5' COPPER CLAD ORDERED SEPARATELY.</p> <p>LIGHTNING ROD PLATE KIT VW133 INCLUDES: LIGHTNING ROD PLATE, (2) CAP PLATES, NUTS AND BOLTS.</p>	 <p>CAP PLATE KIT CP4A (3) CAP PLATES WITH NUTS AND BOLTS.</p>	 <p>10' TAPERED BASE 65TGH* FOR USE WITH 15/16X16PP, ORDERED SEPARATELY.</p>
----------------------------------------------------------------------------------------------------------------------------------------------------------------------------------------------------------------------------------------------------------------------------	--------------------------------------------------------------------------------------------------------------------------------------------------------------------------------------------------------------------------------------------------------------------------------------	-----------------------------------------------------------------------------------------------------------------------------------------------------------------	--------------------------------------------------------------------------------------------------------------------------------------------------------------------------------

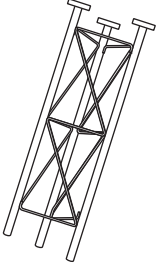
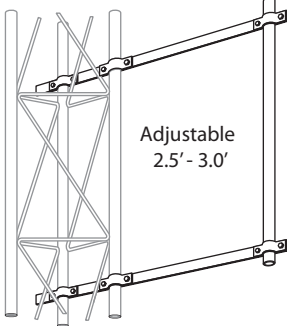
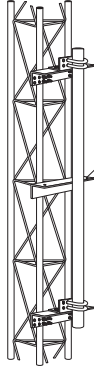
 <p>PIER PIN 15/16X16PP FOR USE WITH 65TGH EMBEDDED IN CONCRETE. PIER PIN MUST BE ORDERED SEPARATELY, UNLESS BEING PURCHASED AS PART OF A COMPLETE TOWER KIT.</p>	 <p>5' SHORT BASE SB65GH FOR EMBEDMENT IN CONCRETE.</p>	 <p>Adjustable 2.5' - 3.0'</p> <p>SIDE ARM ASSEMBLY SA253UA MOUNTING TUBE PROVIDED IS 3' LONG, 2 1/4" O.D.</p>	 <p>Tie-Back Angle with 9/16" dia. holes, included with DM654TB.</p> <p>FACE DISH MOUNT DM654 4 1/2" O.D. X 5' LONG DM654TB 4 1/2" O.D. X 5' LONG WITH TIE-BACK ANGLE.</p>
------------------------------------------------------------------------------------------------------------------------------------------------------------------------------------------------------------------------------------------------------------------------	----------------------------------------------------------------------------------------------------------------------------------------------------------	----------------------------------------------------------------------------------------------------------------------------------------------------------------------------------------------------------------------	---------------------------------------------------------------------------------------------------------------------------------------------------------------------------------------------------------------------------------------------------------------------------------------

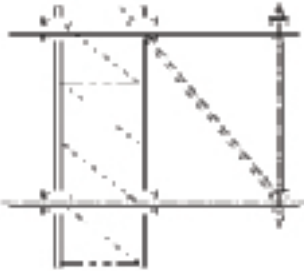
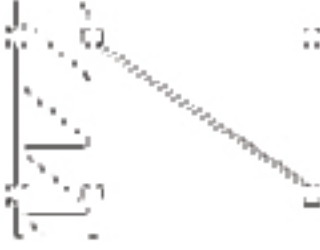
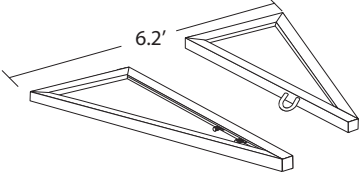
 <p>DISH MOUNT KY509 - 2 3/8" O.D. MAST KY510 - 4 1/2" O.D. MAST MOUNTING TUBE PROVIDED IS 5' LONG.</p>	 <p>3' SIDE ARM KH6100A MOUNTING TUBE PROVIDED IS 7' LONG, 2 3/8" O.D.</p>	 <p>6' SIDE ARM KY1048A MOUNTING TUBE PROVIDED IS 5' LONG, 2 3/8" O.D.</p>	 <p>6.2'</p> <p>HOUSE BRACKET KH1014 ADJUSTABLE TO POSITION 65G 18" - 30" FROM WALL.</p>
---------------------------------------------------------------------------------------------------------------------------------------------------------------------------------------------------------------	------------------------------------------------------------------------------------------------------------------------------------------------------------------------------	-------------------------------------------------------------------------------------------------------------------------------------------------------------------------------	----------------------------------------------------------------------------------------------------------------------------------------------------------------------------------------------

* TOWERS MOUNTED ON THESE BASES MUST BE BRACKETED OR GUYED AT ALL TIMES. TEMPORARY STEEL GUYING MAY ALSO BE NECESSARY DURING INSTALLATION AND DISMANTLING.



PARTS & ACCESSORIES

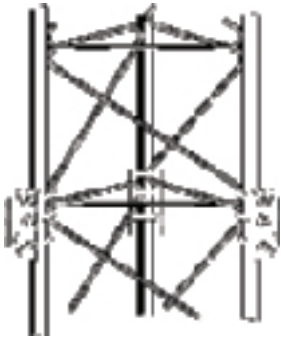

GUY BRACKET ASSEMBLY
GA65GD
KIT INCLUDES (3) BRACKETS WITH
U-BOLTS.



ANTI-CLIMB PANELS
VW915A
THREE ANTI-CLIMB PANELS BOLT
TO STANDARD TOWER SECTION.

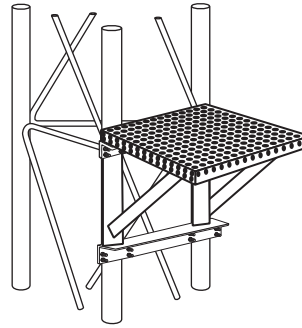

WORK PLATFORM
WPCC65
SNAPS INTO PLACE AT ANY LEVEL.
NO BOLTS REQUIRED.



CLIMBING HARNESS
TTFBH-4D
JOURNEYMAN HARNESS
TTFBH-C/P
PROFESSIONAL HARNESS



**SAFETY CABLE
SLIDER WITH CARABINEER**
TT-WG-500-W/SMC

**SAFETY CABLE SYSTEM
ORDERING INFORMATION**

TOWER HEIGHT	PART NUMBER
50'	TT05065
100'	TT10065
150'	TT15065
200'	TT20065
250'	TT25065
300'	TT30065
350'	TT35065
400'	TT40065
450'	TT45065
500'	TT50065

SAFETY CABLE SLIDER AND
CLIMBING HARNESS MUST BE
ORDERED SEPARATELY.



ANCHOR INFORMATION

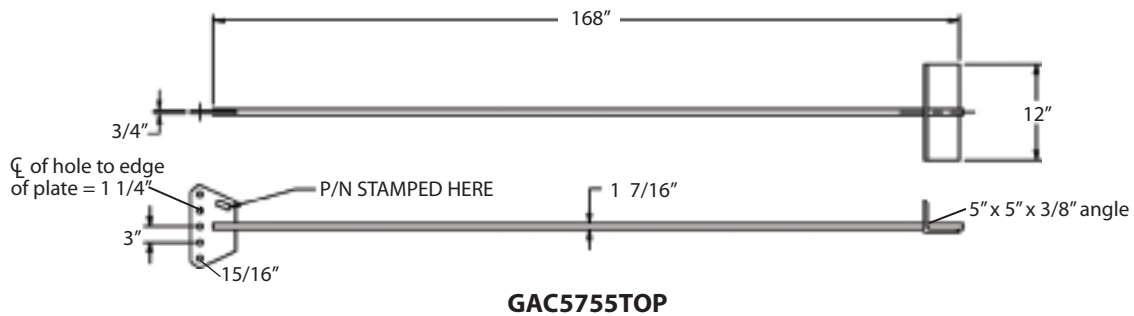
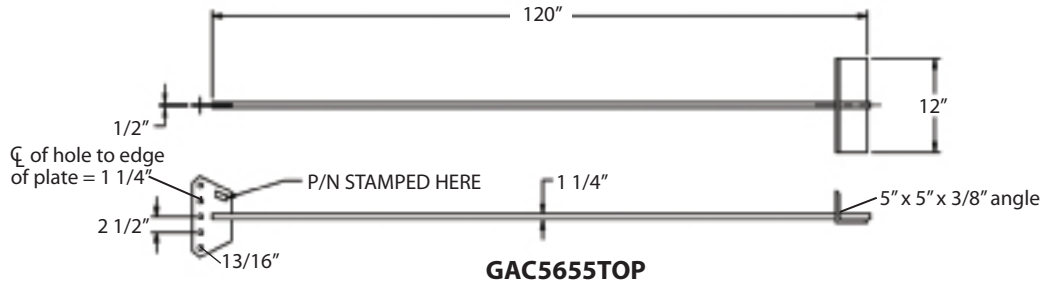
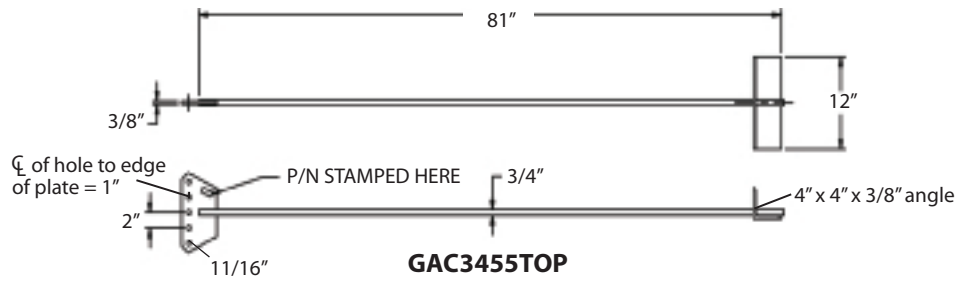

REV G ANCHOR GROUNDING AGK1GGX

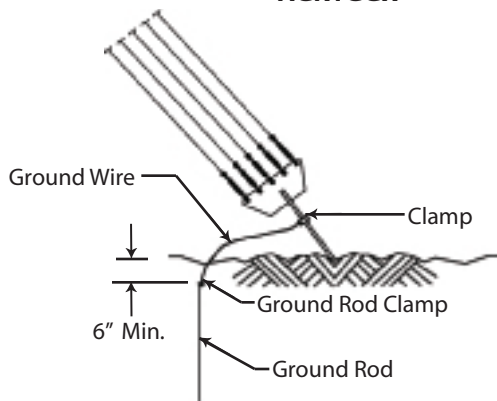

REV G BASE GROUNDING BGK2GGX

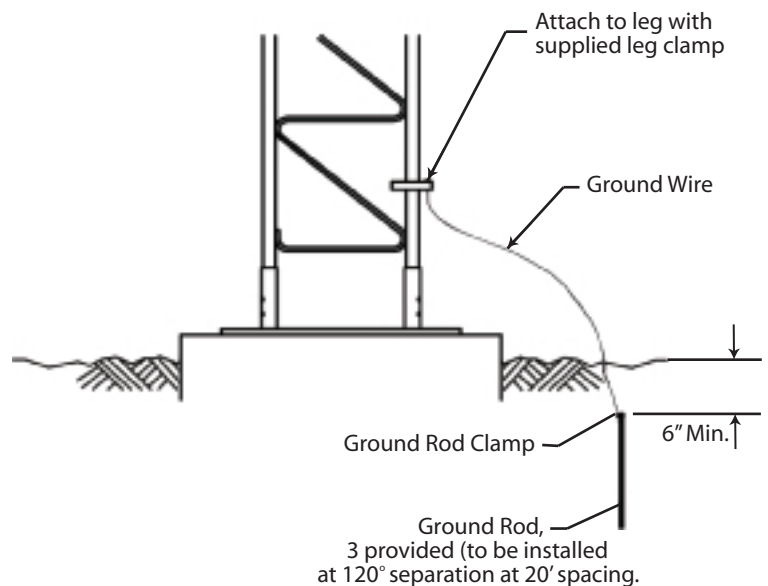

STANDARD ANCHOR BLOCKS

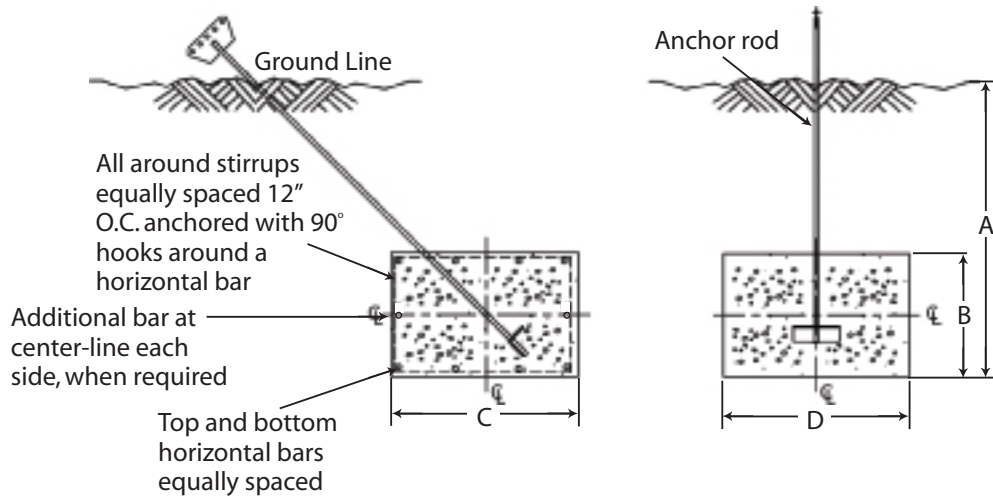

Refer to page 145 for anchor rod installation angles.

Block	Anchor Dimensions (in.)				Horizontal Bars (Qty. & Size)	Stirrup Size & Spacing	Concrete Vol. (Cu. Yds.)
	A	B	C	D			
AB2	4' - 0"	1' - 6"	4' - 0"	6' - 0"	(5) #6 Bars, Top Layer (5) #6 Bars, Bottom Layer (0) Additional Bar, Each Side	#3 @ 12" O.C.	1.33 Per Block 4.0 Total for 3
AB3	6' - 0"	1' - 6"	3' - 0"	6' - 0"	(4) #6 Bars, Top Layer (4) #6 Bars, Bottom Layer (0) Additional Bar, Each Side	#3 @ 12" O.C.	1.0 Per Block 3.0 Total for 3
AB4	6' - 0"	1' - 6"	4' - 0"	9' - 0"	(5) #6 Bars, Top Layer (5) #6 Bars, Bottom Layer (0) Additional Bar, Each Side	#4 @ 12" O.C.	2.0 Per Block 6.0 Total for 3
AB5	8' - 0"	2' - 0"	3' - 0"	10' - 0"	(4) #7 Bars, Top Layer (4) #7 Bars, Bottom Layer (1) Additional Bar, Each Side	#4 @ 12" O.C.	2.22 Per Block 6.7 Total for 3
AB6	8' - 0"	2' - 0"	4' - 0"	10' - 0"	(5) #7 Bars, Top Layer (5) #7 Bars, Bottom Layer (1) Additional Bar, Each Side	#4 @ 12" O.C.	2.96 Per Block 8.9 Total for 3



ANCHOR ROD INSTALLATION ANGLES

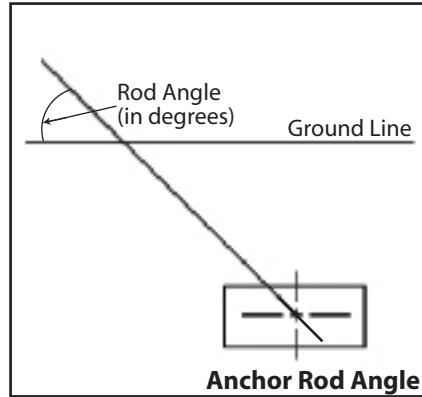
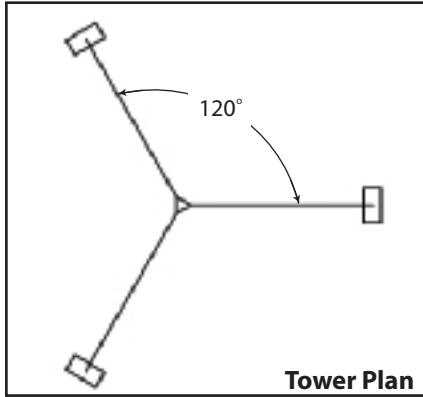

65G 90MPH				
Tower Height	Inner Rod Number	Inner Rod Angle	Outer Rod Number	Outer Rod Angle
100'	GAC3455TOP	44	-	-
110'	GAC3455TOP	44	-	-
120'	GAC3455TOP	44	-	-
130'	GAC3455TOP	44	-	-
140'	GAC3455TOP	42	-	-
150'	GAC3455TOP	42	-	-
160'	GAC5655TOP	42	-	-
170'	GAC5655TOP	41	-	-
180'	GAC5655TOP	41	-	-
190'	GAC5655TOP	41	-	-
200'	GAC5655TOP	41	-	-
220'	GAC5655TOP	40	-	-
240'	GAC5655TOP	39	-	-
260'	GAC5655TOP	39	-	-
280'	GAC5655TOP	38	-	-
300'	GAC5655TOP	38	-	-
320'	GAC5655TOP	38	-	-
340'	GAC3455TOP	43	GAC5655TOP	43
360'	GAC3455TOP	43	GAC5655TOP	43
380'	GAC3455TOP	43	GAC5655TOP	43
400'	GAC3455TOP	40	GAC5655TOP	44
420'	GAC5655TOP	40	GAC5655TOP	43
440'	GAC5655TOP	40	GAC5655TOP	43
460'	GAC5655TOP	40	GAC5755TOP	42
480'	GAC5655TOP	40	GAC5755TOP	42
500'	GAC5655TOP	39	GAC5755TOP	42

65G 110MPH				
Tower Height	Inner Rod Number	Inner Rod Angle	Outer Rod Number	Outer Rod Angle
100'	GAC3455TOP	44	-	-
110'	GAC3455TOP	43	-	-
120'	GAC5655TOP	42	-	-
130'	GAC5655TOP	42	-	-
140'	GAC5655TOP	41	-	-
150'	GAC5655TOP	41	-	-
160'	GAC5655TOP	41	-	-
170'	GAC5655TOP	40	-	-
180'	GAC5655TOP	40	-	-
190'	GAC5655TOP	40	-	-
200'	GAC5655TOP	39	-	-
220'	GAC5655TOP	39	-	-
240'	GAC5655TOP	38	-	-
260'	GAC5755TOP	38	-	-
280'	GAC5755TOP	37	-	-
300'	GAC5755TOP	37	-	-
320'	GAC5755TOP	37	-	-
340'	GAC5655TOP	43	GAC5755TOP	42

65G 130MPH		
Tower Height	Rod Number	Rod Angle
100'	GAC5655TOP	42
110'	GAC5655TOP	42
120'	GAC5655TOP	41
130'	GAC5655TOP	41
140'	GAC5655TOP	40
150'	GAC5655TOP	40
160'	GAC5655TOP	40
170'	GAC5655TOP	39
180'	GAC5655TOP	38
190'	GAC5655TOP	38

STANDARD BASE PIERS

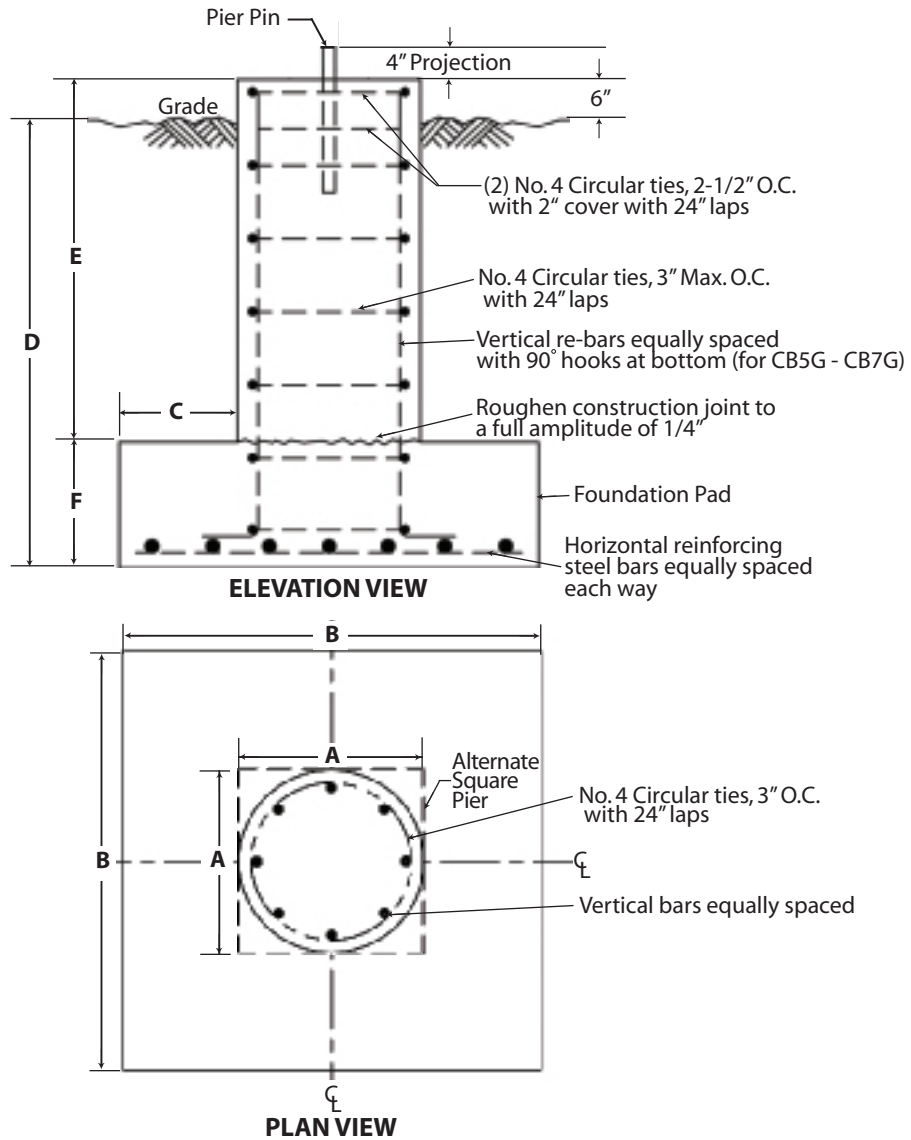

Base	A	B	C	D	E	F	Concrete Vol. (Cu. Yds.) Round Pier	Vertical Bars (No. & Size)	Horiz. Bars in Pad (No. & Size)
CB2G	3' - 0"	3' - 0"	N/A	4' - 0"	N/A	N/A	1.2	(10) #7	NONE
CB3G	3' - 6"	3' - 6"	N/A	4' - 0"	N/A	N/A	1.6	(12) #7	NONE
CB4G	4' - 0"	4' - 0"	N/A	4' - 0"	N/A	N/A	2.1	(12) #8	NONE
CB5G	2' - 0"	4' - 0"	1' - 0"	4' - 0"	3' - 3"	1' - 3"	1.1	(8) #6	(5) #5 (Total of 10)
CB6G	2' - 0"	4' - 6"	1' - 3"	4' - 0"	3' - 3"	1' - 3"	1.3	(8) #6	(6) #5 (Total of 12)
CB7G	2' - 0"	5' - 0"	1' - 6"	4' - 6"	3' - 9"	1' - 3"	1.6	(8) #6	(6) #5 (Total of 12)



GENERAL NOTES FOR G-SERIES TOWERS

1. The suitability of a ROHN standard design and standard foundation for a specific application must be verified by the purchaser based on site-specific data in accordance with ANSI/TIA-222-G.
2. The effective projected area and lines to be installed must not exceed the design values for the structure.
3. Structures supported on buildings or other structures require special consideration. Designs assume structures are installed on level grade.
4. Designs assume maintenance and inspection will be performed over the life of the structure in accordance with ANSI/TIA-222-G. All towers should be thoroughly inspected by qualified personnel and re-marked as required with appropriate danger and anti-climb labels at least twice a year to ensure safety and proper performance.
5. Standard Designs are intended to be climbed by skilled and competent climbers only. A safety climb system is required for all structures.
6. Installation and dismantling must be performed by qualified and experienced personnel and be in conformance with ANSI/TIA-222-G.
7. Standard guyed masts and bracketed towers are not stable without guys or brackets attached and will not support personnel in this condition. Temporary steel guys supplied by a qualified contractor may be required to maintain stability during installation or dismantling.
8. Do not install or dismantle structures within falling distance of electrical and/or telephone lines without taking special precautions in accordance with the appropriate utility.
9. All field connections are bolted.
10. The tolerance on installed height is equal to plus 1% and minus 1/2%.
11. Installation must be grounded in accordance with local and national codes. ANSI/TIA-222-G requires that the resistance to ground must not exceed 10 ohms. Additional grounding may be required in addition to the ROHN standard grounding kit provided with the tower.
12. Additional anchor rod corrosion protection may be required based on site-specific conditions.
13. Installation must be in conformance with local, state and federal requirements for obstruction marking and lighting.
14. Warning plate P/N: AWCS provided with the structure must be installed in a highly visible location.

G-SERIES FOUNDATION GENERAL NOTES

1. Standard foundation designs (unless otherwise noted) are in accordance with ANSI/TIA-222-G, "Structural Standards for Steel Antenna Towers and Antenna Supporting Structures," Section 9 and Annex F for the following presumptive clay soil parameters:

N (blows/ft)	ϕ (deg)	γ (lb/ft ³)	c (psf)	Ultimate Bearing (psf)		Ultimate Skin Friction (psf)	k (pci)	ε ₅₀
				Shallow Fdns.	Deep Fdns.			
8	0	110	1000	5000	9000	500	150	0.01

2. The purchaser must verify that actual site soil parameters meet or exceed the assumed soil conditions and that the depth of standard foundations are adequate based on the frost penetration and/or zone of seasonal moisture variation at the site. Foundation design modifications may be required in the event the assumed soil parameters are not applicable for the actual subsurface conditions encountered.



G-SERIES FOUNDATION GENERAL NOTES

3. Foundation designs assume field inspections will be performed by the purchasers' representative to verify that construction materials, installation methods and assumed design parameters are acceptable based on the conditions existing at the site.
4. Work shall be in accordance with local codes, safety regulations and unless otherwise noted, the latest revision of ACI 318, "Building Code Requirements for Reinforced Concrete." Procedures for the protection of excavations, existing construction and utilities shall be established prior to foundation installations.
5. Concrete materials shall conform to the appropriate state requirements for exposed structural concrete.
6. Proportions of concrete materials shall be suitable for the installation method utilized and shall result in durable concrete for resistance to local anticipated aggressive actions. The durability requirement of ACI 318 Chapter 4 shall be satisfied based on the conditions expected at the site. As a minimum, concrete shall develop a minimum compressive strength of 4000 psi in 28 days.
7. Maximum size of aggregate shall not exceed the size suitable for the installation method utilized or 1/3 the clear distance behind or between reinforcing. Maximum size may be increased to 2/3 the clear distance provided workability and methods of consolidation such as vibrating will prevent honeycombs or voids.
8. Reinforcement shall be deformed and conform to the requirements of ASTM A615 Grade 60 unless otherwise noted. Splices in reinforcement shall not be allowed unless otherwise indicated.
9. Reinforcing cages shall be braced to retain proper dimensions during handling and throughout placement of concrete.
10. Welding is prohibited on reinforcing steel and embedments.
11. Minimum concrete cover for reinforcement shall be 3 inches unless otherwise noted. Appropriate spacers shall be used to insure a 3 inch minimum cover on reinforcement.
12. Concrete cover from top of foundations to ends of vertical reinforcement shall not exceed 3 inches nor be less than 2 inches.
13. Spacers shall be attached intermittently throughout the entire length of vertical reinforcing cages to insure concentric placement.
14. Foundation designs assume structural backfill to be compacted in 8 inch maximum layers to 95% of maximum dry density at optimum moisture content in accordance with ASTM D698. Additionally, structural backfill must have a minimum compacted until weight of 100 pounds per cubic foot.
15. Foundation designs assume level grade at the site.
16. Foundation installations shall be supervised by personnel knowledgeable and experienced with the proposed foundation type. Construction shall be in accordance with generally accepted installation practices.
17. Loose material shall be removed from bottom of excavations prior to concrete placement. Sides of excavations shall be rough and free of loose cuttings.
18. Concrete shall be placed in a manner that will prevent segregation of concrete materials and other occurrences which may decrease strength or durability.
19. Free fall concrete may be used provided fall is vertical down without hitting sides of excavation, form work, reinforcing bars, form ties, cage bracing or other obstructions. Under no circumstances shall concrete fall through water.
20. Concrete shall be placed against undisturbed soil except for piers in pier and pad foundations. Forms for piers shall be removed prior to placing structural backfill.
21. Construction joints, if required in piers must be at least 12 inches below bottom of embedments and must be intentionally roughened to a full amplitude of 1/4 inch. Foundation designs assume no other construction joints.
22. Tops of foundations shall be sloped to drain with a floated finished.
23. Exposed edges of concrete shall be chamfered 3/4" x 3/4".
24. Additional corrosion protection may be required for steel guy anchors in direct contact with soil. Design assumes periodic inspections will be performed over the life of the structure to determine if additional anchor corrosion protection measures must be implemented based on observed site-specific conditions.

FOUNDATION TOLERANCES

GENERAL

1. Concrete dimensions - plus 2" or minus 0".
2. Depth of foundation - plus 3" or minus 0".
3. Drilled foundations out-of-plumb - 1.0 degree.
4. Reinforcing steel placement - per A.C.I. 301.
5. Projection of embedments - plus or minus 1/8".
6. Vertical embedments out of plumb - 0.5 degree.

GUY ANCHORS

1. Guy radius - plus or minus 5% of distance specified.
2. Anchor elevation - plus or minus 5% of guy radius.
3. Anchor alignment (perpendicular to guy radius) - 1.0 degree.
4. Anchor rod slope - plus or minus 1.0 degree.
5. Anchor rod alignment with guy radius - plus or minus 1.0 degree.
6. Anchor head out of plumb - 1.0 degree.
7. Guy initial tension - plus or minus 10% of tension specified.

Note: Tolerances in notes 1 & 2 cannot occur simultaneously.



GUY ARRANGEMENT DETAILS

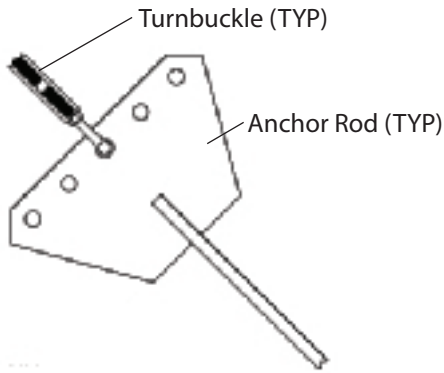

1 Guy Attachment

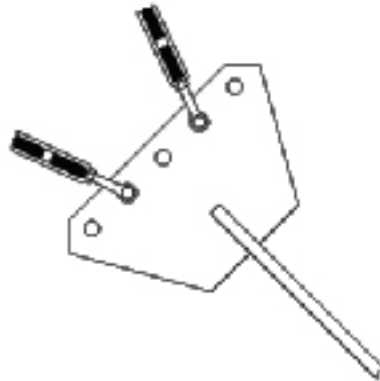

2 Guy Attachment

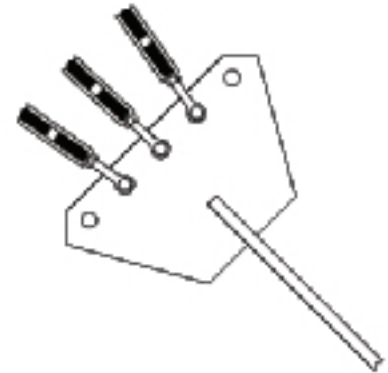

3 Guy Attachment

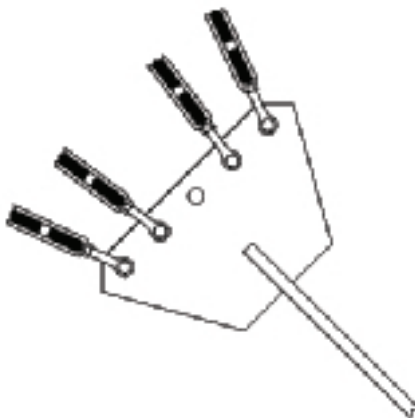

4 Guy Attachment

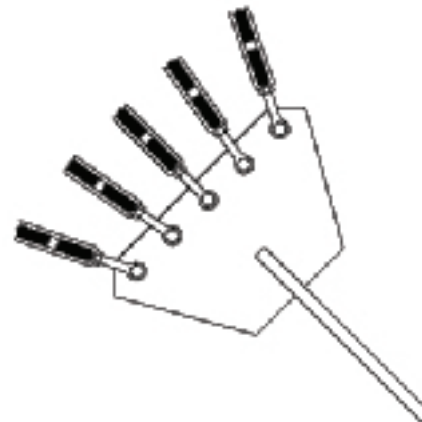

5 Guy Attachment

Wire Size	Anchor Rod	Turnbuckle	Thimble	Big Grip w/ End Sleeve
3/16 EHS	GAC3455TOP	1/2TBE&J	5/16THH	BG2142
	GAC5655TOP	5/8TBE&J	5/16THH	
1/4EHS	GAC3455TOP	1/2TBE&J	3/8THH	BG2144
	GAC5655TOP	5/8TBE&J	3/8THH	
	GAC5755TOP	3/4TBE&J	3/8THH	
5/16EHS	GAC3455TOP	5/8TBE&J	7/16THH	BG2146
	GAC5655TOP	5/8TBE&J	7/16THH	
	GAC5755TOP	3/4TBE&J	7/16THH	
3/8EHS	GAC3455TOP	5/8TBE&J	1/2THH	BG2174
	GAC5655TOP	5/8TBE&J	1/2THH	
	GAC5755TOP	3/4TBE&J	1/2THH	

GUY ANCHOR CONNECTION DETAILS

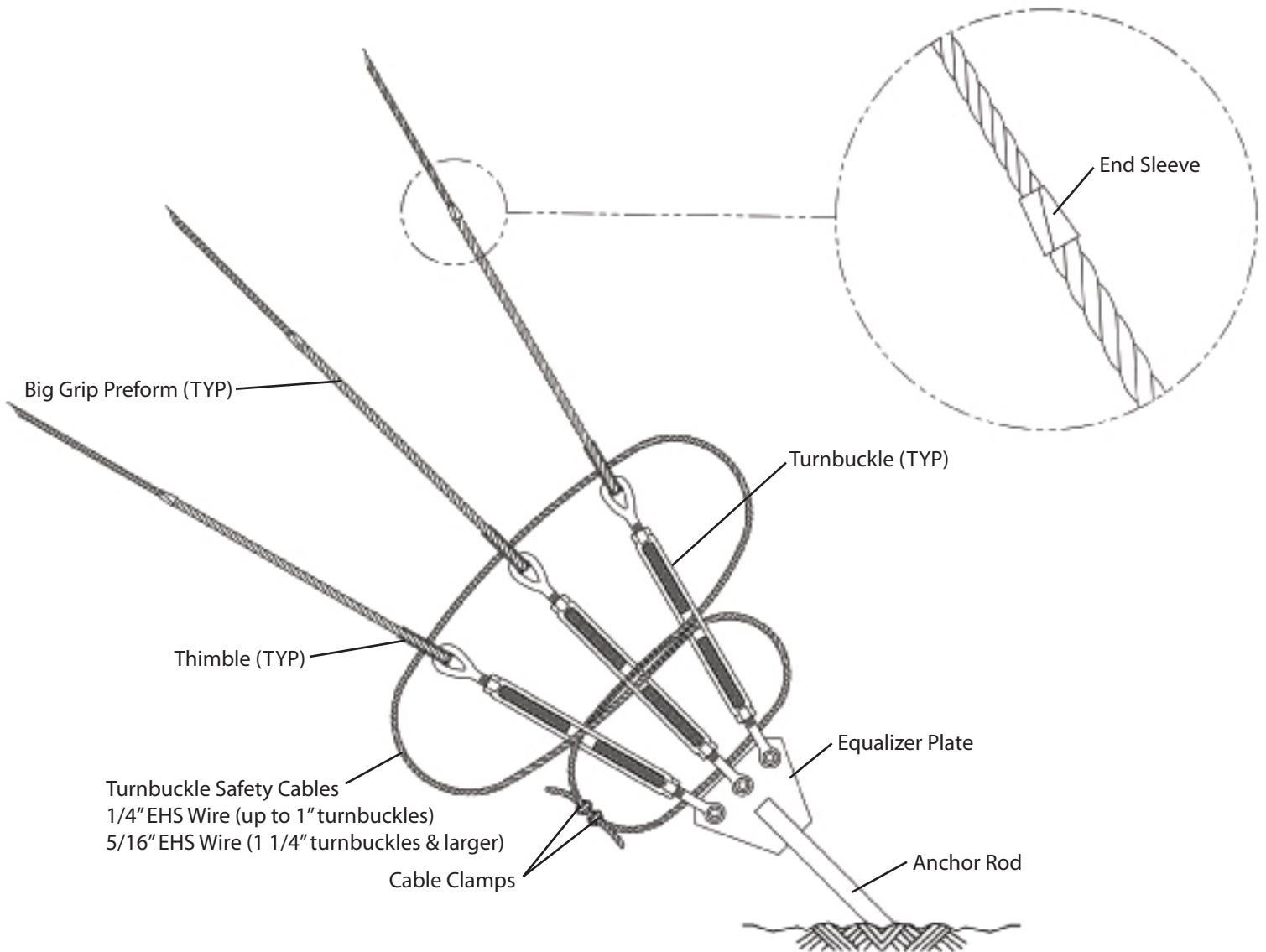

Anchor Connection



GUY MAST CONNECTION DETAILS

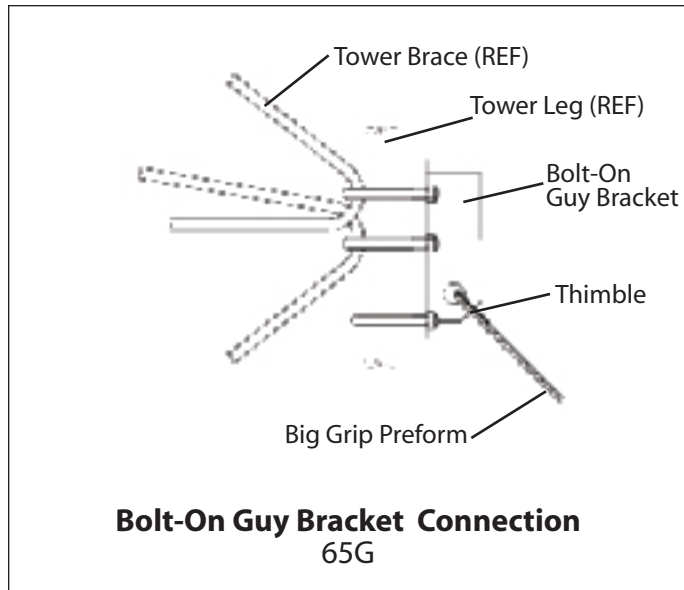
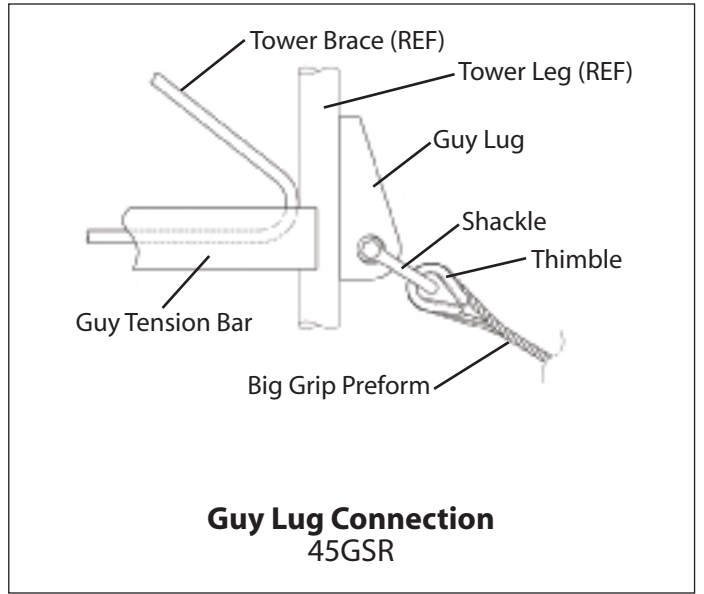
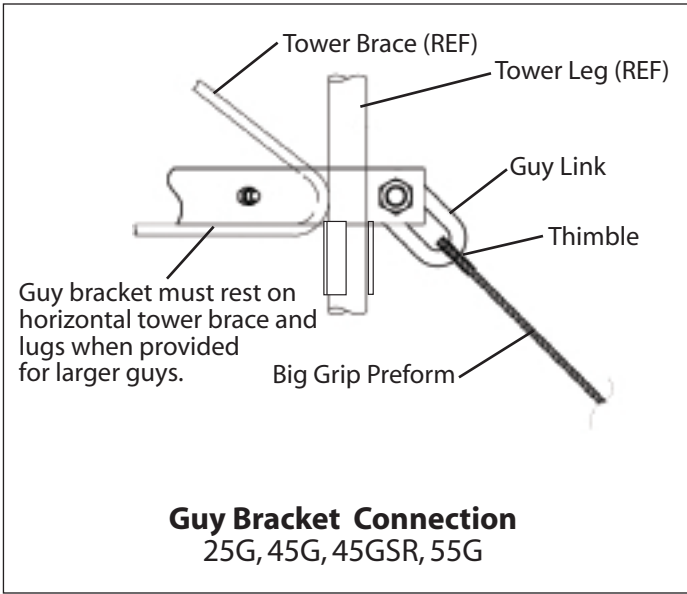

PAL NUT INSTALLATION

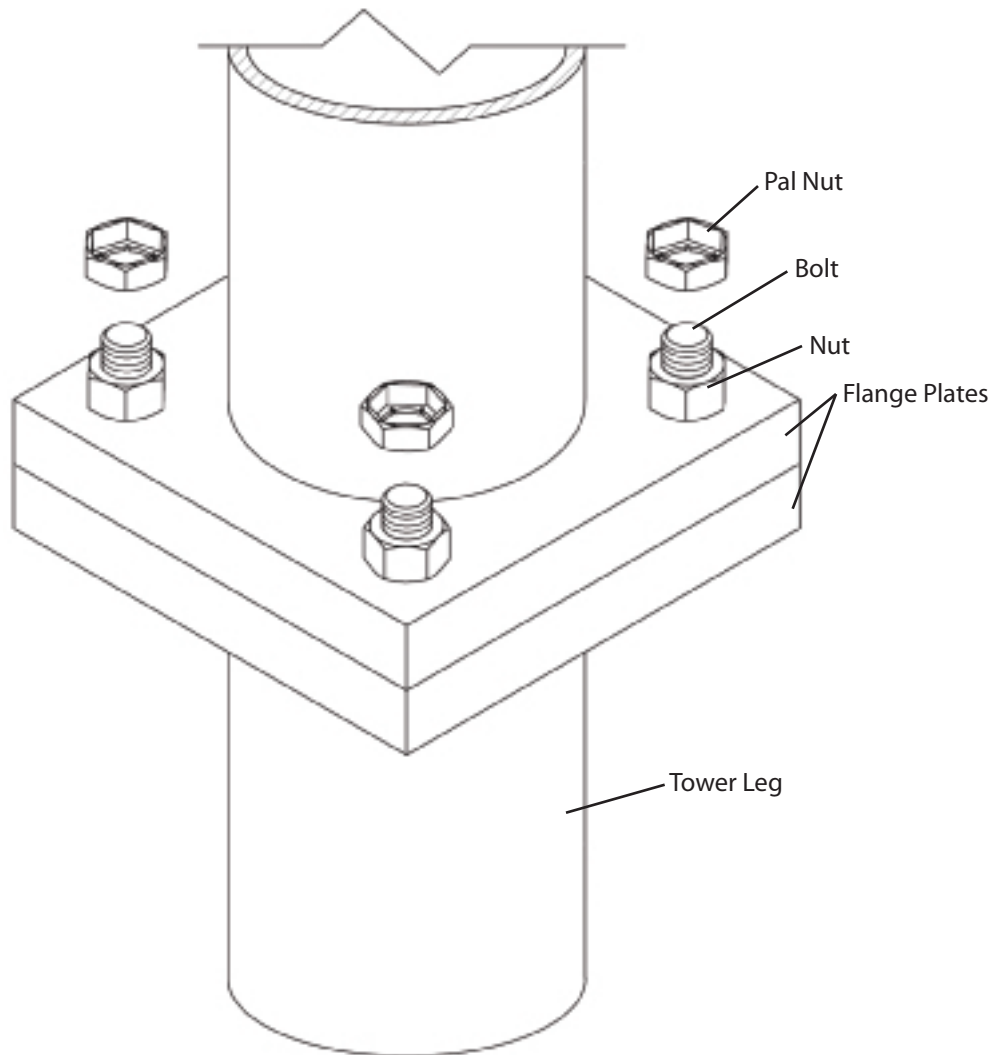

When pal nuts are provided, they are to be installed after nuts are tight and with edge lip out as shown. Pal nuts are not required when self-locking nuts or lock washers are provided.



STANDARD 80 SERIES GUYED TOWER

80 SERIES

GENERAL USE

The ROHN Model 80 Guyed Tower is designed with variable sized legs and braces to allow construction to heights of 1000'. This tower uses solid or tubular legs with angle or tubular braces to support microwave, cellular, PCS, AM/FM or TV applications. The tower is designed on an equilateral triangle of 41" center-to-center of each leg. The variable leg and brace sizes allow flexibility in design so a tower can be created specifically for your unique requirements.

FEATURES

- Solid or Tubular Legs
- Angle or Tubular Braces
- Completely hot-dip galvanized after fabrication
- Easily reinforced for additional loading capability
- Multiple section lengths available
- Guy lug and torque arm sections available



Per Rev G requirements, any structure greater than 10' requires a climber safety device. Please contact ROHN for ordering information.



STANDARD 80 GUYED TOWER SECTIONS

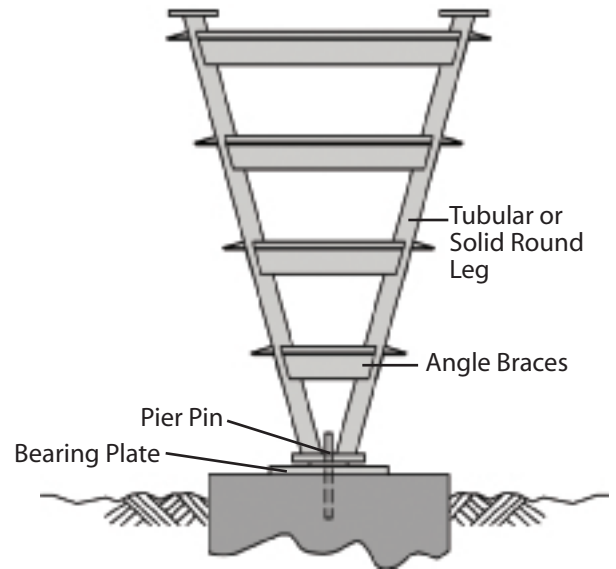
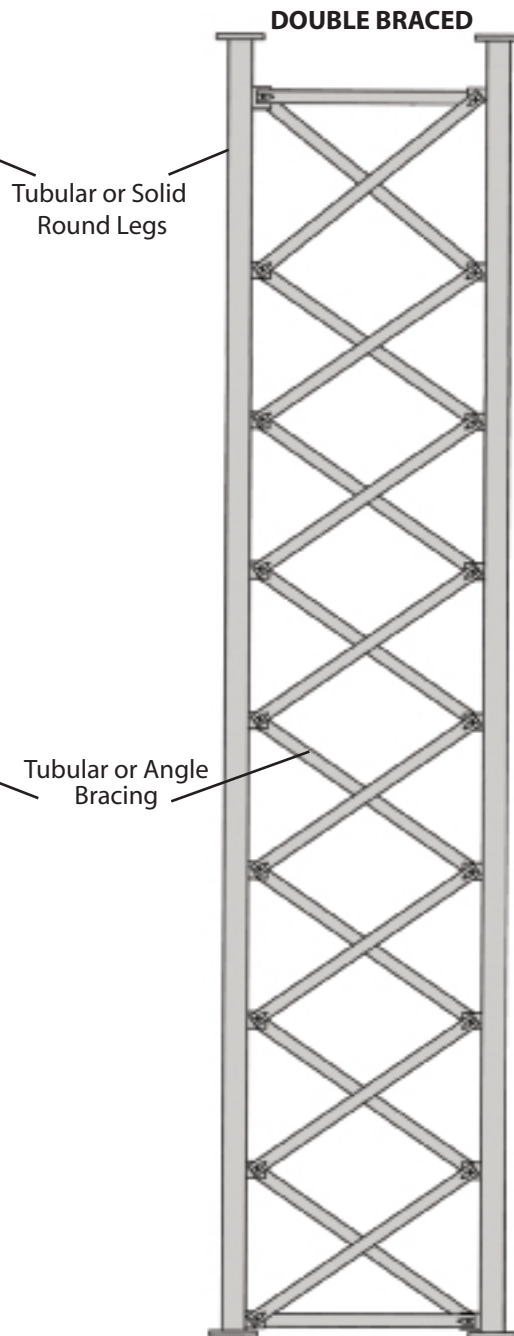
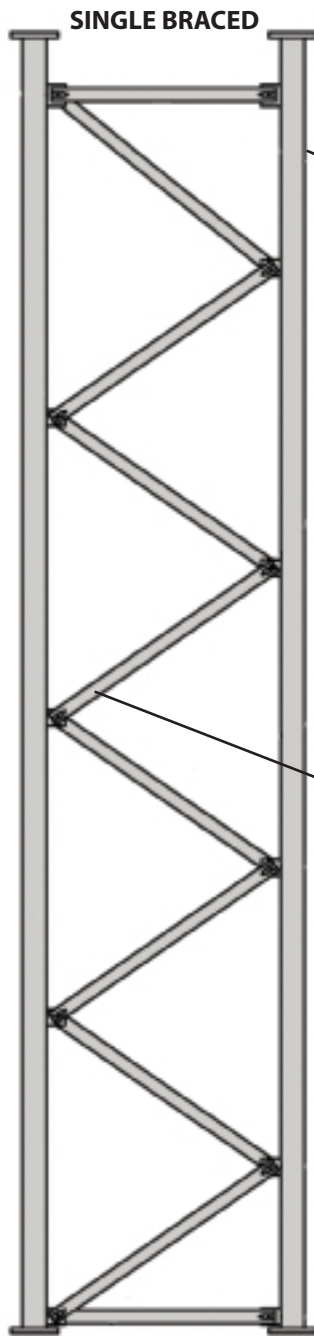
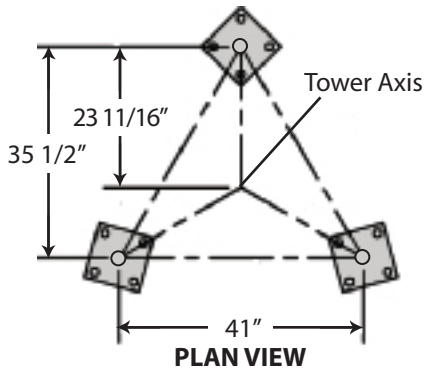

5' TAPERED BASE

20' STANDARD SECTION

80 Sections have several custom designs available depending on your particular specifications. Sections are available with a variety of different wall thicknesses, bracing patterns and lengths.



STANDARD 90 SERIES GUYED TOWER

90 SERIES

GENERAL USE

The ROHN Model 90 Guyed tower is designed specifically for microwave installations, cellular, PCS, other heavy duty communication, TV and FM broadcast and meteorological equipment installations. This series has a rating for installations up to 1500', using variable size and weight of tubular or solid steel components. The tower is designed on an equilateral triangle of 60 1/2" center-to-center of each leg. The "X" brace design of the 90 series maximizes strength in critical areas as well as allows for future upgrading of the tower for additional loads.

FEATURES

- Solid or Tubular Legs
- Angle Braces
- Completely hot-dip galvanized after fabrication
- Easily reinforced for additional loading capability
- Multiple section lengths available
- Guy lug and torque arm sections available



Per Rev G requirements, any structure greater than 10' requires a climber safety device. Please contact ROHN for ordering information.

STANDARD 90 GUYED TOWER SECTIONS

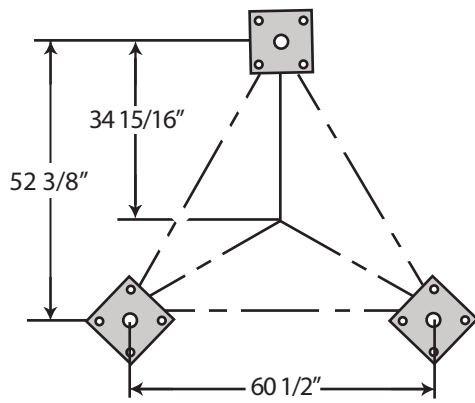

Custom designs with larger face widths are available for broadcast and other applications.

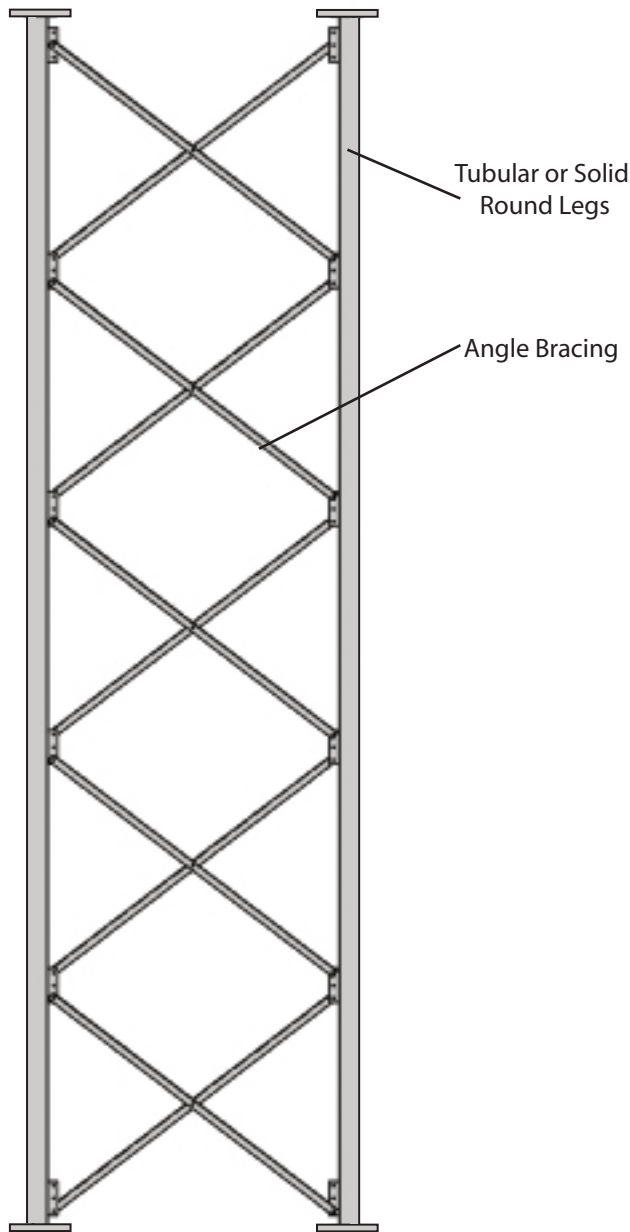

**ELEVATION
20' STANDARD SECTION**

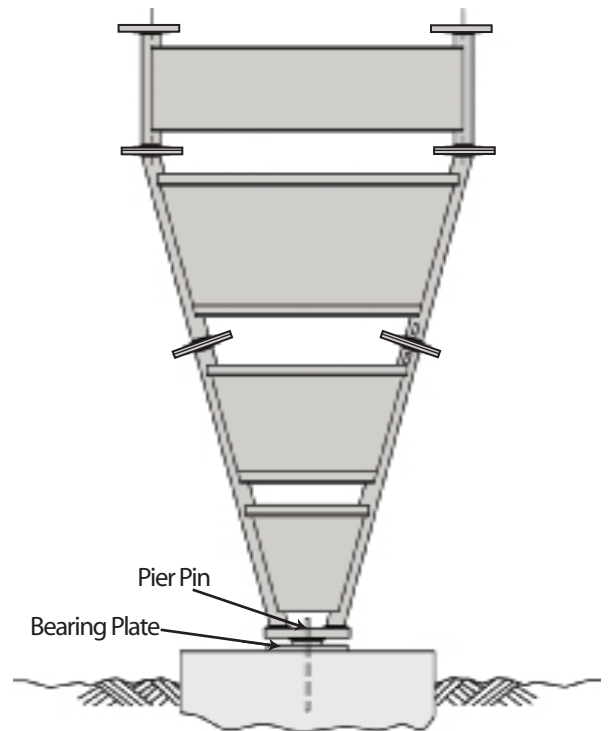

**TAPERED BASE
STANDARD - 10'
Also available in 8'**

90 Sections have several custom designs available depending on your particular specifications. Sections are available with a variety of different wall thicknesses, bracing patterns and lengths.

NOTES

BRACKETED TOWERS



STANDARD G-SERIES BRACKETED

G-SERIES (BRACKETED)

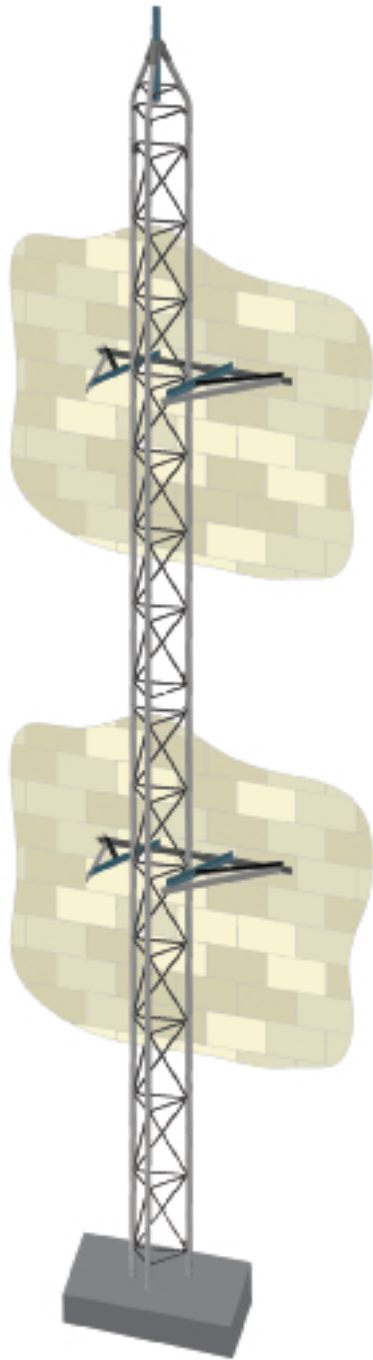

Typical installation on short base with (2) HBUTVRO brackets.

(Refer to G-Series accessories for short base)

GENERAL USE

ROHN G-Series Bracketed towers can be installed adjacent to buildings using brackets to secure the tower along the height of the structure.

FEATURES

- Completely hot-dip galvanized after fabrication
- Cross bracing is formed by a continuous solid rod bracing fashioned into a Zig-Zag pattern for strength
- Pre-engineered loading charts to meet varying individual specs and site conditions
- Typical uses include: small dishes, broadband, security and two-way communication.

OPTIONAL ACCESSORY

**UNIVERSAL HOUSE BRACKET
HBUTVRO**

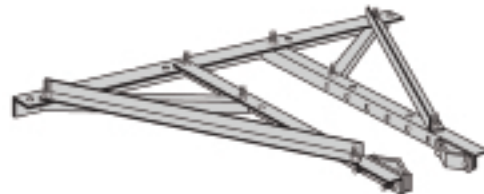

Adjustable to position tower 18" - 36" from wall.

* Per Rev. G requirements, any structure greater than 10' requires a climber safety device. Please see page 209 for ordering information.

25G BRACKETED ALLOWABLE ANTENNA AREAS

Tower Height (FT.)	Bracket Elevations		Allowable Antenna Areas (SQ. FT.)		
	Upper (FT.)	Lower (FT.)	70 [85] MPH	80 [95] MPH	90 [105] MPH
40	30.0	15.0	15.3	11.3	7.7
50	36.0	18.0	14.6	10.0	6.8
60	46.0	23.0	14.0	8.9	5.9
70	56.0	28.0	13.5	8.3	5.5
80	66.0	33.0	13.1	7.7	5.0
90	66.0	33.0	6.8	4.9	-
100	66.0	33.0	1.7	-	-

25G

1. Tower designs are in accordance with ANSI/EIA-222-F. Wind speeds indicated as fastest mile [3-second gust].
2. All towers must have "fixed bases" with both bracket elevations. Pinned bases must not be used.
3. Designs assume one 5/8" transmission line on each face (total=3), symmetrically placed.
4. Antennas and mounts assumed symmetrically placed at tower apex.
5. Allowable antenna areas assume all round antenna members.
6. Allowable flat-plate antenna areas, based on EIA RS-222-C, may be obtained by multiplying areas shown by 0.6.
7. All brackets are to be ROHN (P/N HBUTVRO).
8. The interface of tower brackets to supporting structure is to be designed by others and must support a minimum horizontal force of 815 lbs.
9. Foundation designs are in accordance with ANSI/TIA/EIA-222-F, "Structural Standards for Steel Antenna Towers and Antenna Supporting Structures," Section 7, for "Normal" soil conditions. "Normal" soil is defined as dry, cohesive soil with an allowable net vertical bearing capacity of 4000 PSF and an allowable net horizontal pressure of 400 PSF per linear foot of depth to a maximum of 4000 PSF.

Refer to pages 147-153 for General Installation and Foundation Notes.

FOUNDATION INFORMATION

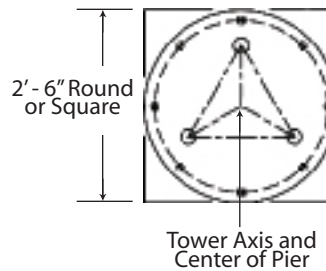
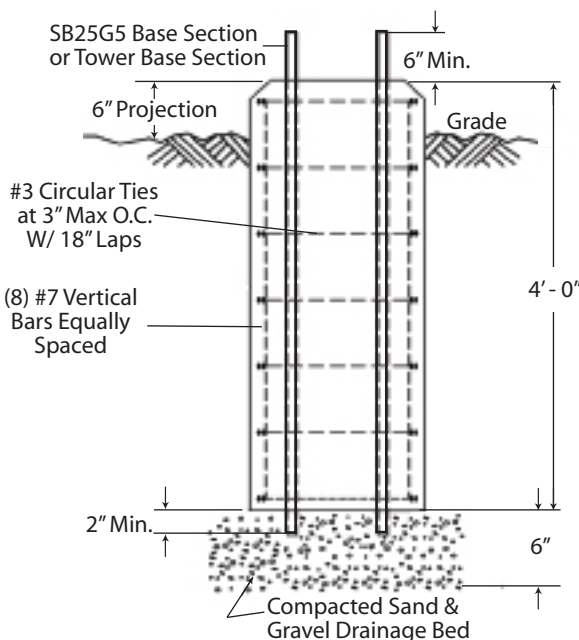

VOLUME OF CONCRETE	
Square Pier	= 1.0 cu. yds.
Round Pier	= 0.8 cu. yds.

45G BRACKETED ALLOWABLE ANTENNA AREAS

45G

Tower Height (FT.)	Bracket Elevations		Allowable Antenna Areas (SQ. FT.)		
	Upper (FT.)	Lower (FT.)	70 [85] MPH	80 [95] MPH	90 [105] MPH
40	30.0	15.0	36.7	27.4	21.0
50	36.0	18.0	34.8	25.9	20.0
60	46.0	23.0	33.3	24.7	19.0
70	56.0	28.0	32.0	23.8	17.0
80	66.0	33.0	31.0	23.0	12.0
90	66.0	33.0	13.8	9.3	5.3
100	66.0	33.0	5.5	2.0	-

1. Tower designs are in accordance with ANSI/EIA-222-F. Wind speeds indicated as fastest mile [3-second gust].
2. All towers must have "fixed bases" with both bracket elevations. Pinned bases must not be used.
3. Designs assume one 5/8" transmission line on each face (total=3), symmetrically placed.
4. Antennas and mounts assumed symmetrically placed at tower apex.
5. Allowable antenna areas assume all round antenna members.
6. Allowable flat-plate antenna areas, based on EIA RS-222-C, may be obtained by multiplying areas shown by 0.6.
7. All brackets are to be ROHN (P/N HBUTVRO).
8. The interface of tower brackets to supporting structure is to be designed by others and must support a minimum horizontal force of 1810 lbs.
9. Foundation designs are in accordance with ANSI/TIA/EIA-222-F, "Structural Standards for Steel Antenna Towers and Antenna Supporting Structures", Section 7, for "Normal" soil conditions. "Normal" soil is defined as dry, cohesive soil with an allowable net vertical bearing capacity of 4000 PSF and an allowable net horizontal pressure of 400 PSF per linear foot of depth to a maximum of 4000 PSF.

Refer to pages 147-153 for General Installation and Foundation Notes.

FOUNDATION INFORMATION

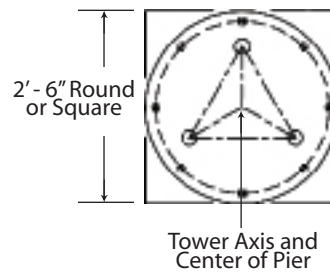
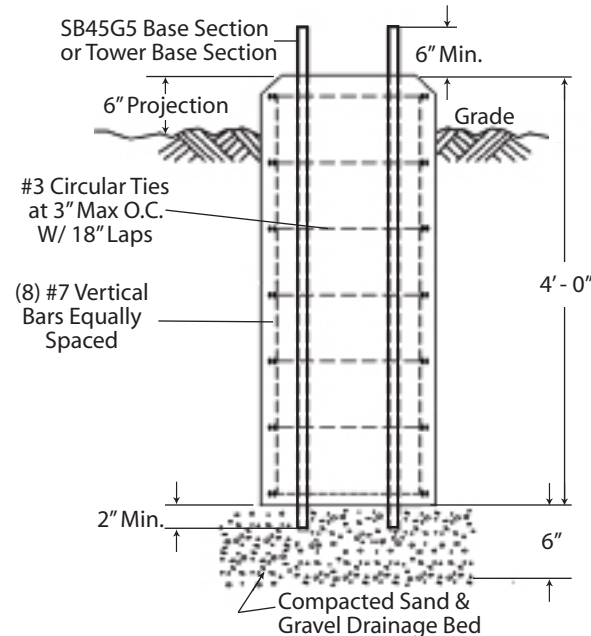

VOLUME OF CONCRETE

Square Pier = 1.0 cu. yds.
 Round Pier = 0.8 cu. yds.

55G BRACKETED ALLOWABLE ANTENNA AREAS

Tower Height (FT.)	Bracket Elevations		Allowable Antenna Areas (SQ. FT.)		
	Upper (FT.)	Lower (FT.)	70 [85] MPH	80 [95] MPH	90 [105] MPH
40	30.0	15.0	72.4	54.5	41.8
50	36.0	18.0	68.7	51.7	39.4
60	46.0	23.0	65.8	49.5	37.6
70	56.0	28.0	63.5	47.5	36.0
80	66.0	33.0	61.4	46.0	34.6
90	66.0	33.0	30.6	22.0	16.0
100	66.0	33.0	16.0	10.5	6.4

55G

1. Tower designs are in accordance with ANSI/EIA-222-F. Wind speeds indicated as fastest mile [3-second gust].
2. All towers must have "fixed bases" with both bracket elevations. Pinned bases must not be used.
3. Designs assume one 5/8" transmission line on each face (total=3), symmetrically placed.
4. Antennas and mounts assumed symmetrically placed at tower apex.
5. Allowable antenna areas assume all round antenna members.
6. Allowable flat-plate antenna areas, based on EIA RS-222-C, may be obtained by multiplying areas shown by 0.6.
7. All brackets are to be ROHN (P/N HBUTVRO).
8. The interface of tower brackets to supporting structure is to be designed by others and must support a minimum horizontal force of 3200 lbs.
9. Foundation designs are in accordance with ANSI/TIA/EIA-222-F, "Structural Standards for Steel Antenna Towers and Antenna Supporting Structures", Section 7, for "Normal" soil conditions. "Normal" soil is defined as dry, cohesive soil with an allowable net vertical bearing capacity of 4000 PSF and an allowable net horizontal pressure of 400 PSF per linear foot of depth to a maximum of 4000 PSF.

Refer to pages 147-153 for General Installation and Foundation Notes.

FOUNDATION INFORMATION

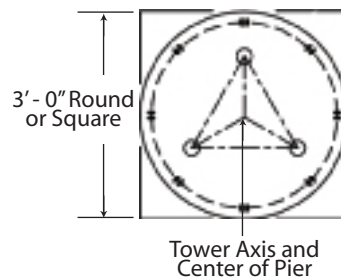
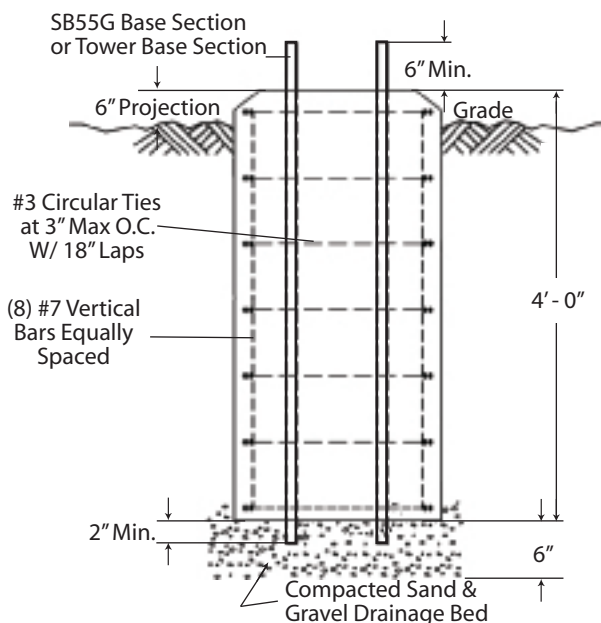

VOLUME OF CONCRETE	
Square Pier	= 1.4 cu. yds.
Round Pier	= 1.1 cu. yds.

NOTES

SELF-SUPPORTING TOWERS



STANDARD G-SERIES SELF-SUPPORTING



G-SERIES SELF-SUPPORTING

GENERAL USE

The self-supporting G-Series towers offer an easy, low-cost solution to get light weight antennas in the air quickly. By using the G-Series tower as a self-supporting structure, you minimize land area usage. They are functional in a wide variety of wind speeds. See ROHN's standard designs to help identify the right structure for your project. These are the same sturdy, robust tower sections that ROHN has fabricated for years. Each larger model allows for more loading capacity.

FEATURES

- Completely hot-dip galvanized after fabrication
- Cross bracing is formed by a continuous solid rod bracing fashioned into a zig-zag pattern for strength
- Pre-engineered loading charts meet varying individual specs and site conditions
- Typical uses include: small dishes, broadband, security and two-way communication
- All towers have 'fixed' bases

KITS

The kit part numbers for ROHN Self-Supporting G-Series towers include:

- Short base for embedment in concrete
- Rev F ground kit (Rev G optional)
- All tower sections and connection hardware
- Tapered top (25G and 45G towers)
- Top plate (55G towers)
- Cap plate kit (65G towers)

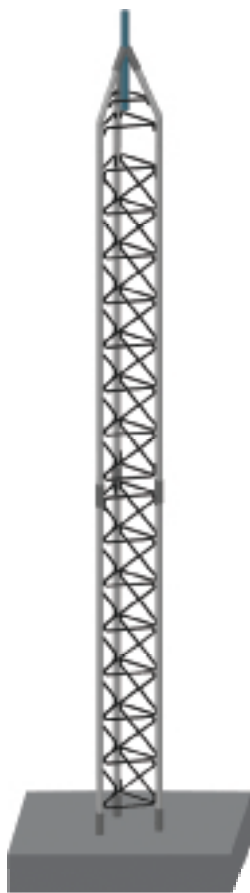

Typical Self-Supporting
25G, 45G and 55G Tower
(Tapered top available
for 25G & 45G only)

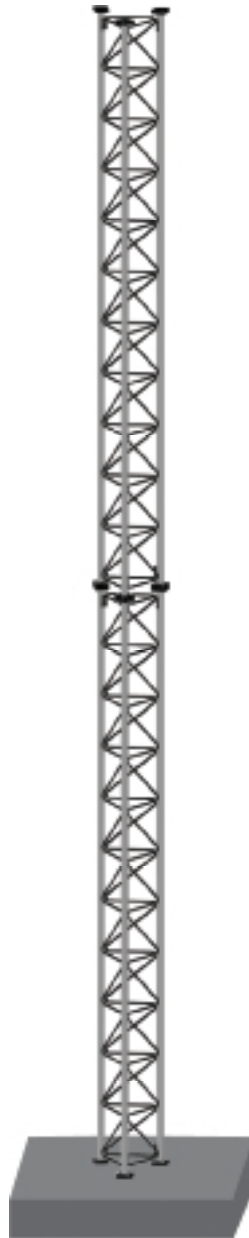

Typical Self-Supporting
45GSR and 65G Tower

Per Rev G requirements, any structure greater than 10' requires a climber safety device. Please see page 209 for ordering information.



G SERIES
REV. F ALLOWABLE ANTENNA AREAS (SQ. FT.)

70 MPH
Fastest Mile

70 MPH Fastest Mile Wind Speed - No Ice								
Height	25G		45G		55G		65G	
	FT ²	Part No.	FT ²	Part No.	FT ²	Part No.	FT ²	Part No.
10'	19.7	25SS010	42.5	45SS010	75.0	55SS010	95.0	65SS010
20'	14.2	25SS020	22.0	45SS020	43.0	55SS020	95.0	65SS020
30'	6.4	25SS030	12.0	45SS030	26.0	55SS030	76.2	65SS030
35'	3.6	25SS035	8.7	45SS035	21.9	55SS035	61.2	65SS035
40'	1.5	25SS040	5.1	45SS040	15.0	55SS040	48.8	65SS040
45'			2.3	45SS045	11.4	55SS045	39.0	65SS045
50'					6.5	55SS050	29.3	65SS050
55'					4.0	55SS055	24.4	65SS055
60'					0.8	55SS060	18.4	65SS060
70'							8.7	65SS070
80'							0.9	65SS080

80 MPH
Fastest Mile

80 MPH Fastest Mile Wind Speed - No Ice								
Height	25G		45G		55G		65G	
	FT ²	Part No.	FT ²	Part No.	FT ²	Part No.	FT ²	Part No.
10'	14.3	25SS010	30.0	45SS010	57.0	55SS010	95.0	65SS010
20'	9.0	25SS020	16.0	45SS020	30.0	55SS020	85.0	65SS020
30'	3.7	25SS030	7.5	45SS030	17.0	55SS030	55.8	65SS030
35'	1.4	25SS035	4.7	45SS035	14.5	55SS035	44.0	65SS035
40'			1.4	45SS040	8.0	55SS040	34.1	65SS040
45'					5.9	55SS045	26.2	65SS045
50'					1.5	55SS050	19.7	65SS050
55'							14.5	65SS055
60'							9.4	65SS060
70'							1.3	65SS070

90 MPH
Fastest Mile

90 MPH Fastest Mile Wind Speed - No Ice								
Height	25G		45G		55G		65G	
	FT ²	Part No.	FT ²	Part No.	FT ²	Part No.	FT ²	Part No.
10'	10.5	25SS010	25.0	45SS010	45.0	55SS010	95.0	65SS010
20'	6.9	25SS020	11.0	45SS020	23.0	55SS020	65.0	65SS020
30'	1.7	25SS030	4.0	45SS030	12.0	55SS030	40.0	65SS030
35'			1.9	45SS035	9.4	55SS035	32.2	65SS035
40'					4.0	55SS040	24.1	65SS040
45'					2.2	55SS045	17.7	65SS045
50'							14.5	65SS050
55'							7.7	65SS055
60'							3.3	65SS060

NO ICE

Note: Antenna areas, ft.², assume all round antenna members.



G SERIES

REV. G EFFECTIVE PROJECTED AREA (SQ. FT.)

90 MPH
3-Second Gust

90 MPH 3-Second Gust Wind Speed															
Height	25G			45G			45GSR			55G			65G		
	EPA		Part No.	EPA		Part No.	EPA		Part No.	EPA		Part No.	EPA		Part No.
	Exp.B	Exp.C		Exp.B	Exp.C		Exp.B	Exp.C		Exp.B	Exp.C		Exp.B	Exp.C	
10'	26.8	21.3	25SS010	60.0	47.5	45SS010	95	84	45SR010	80	79	55SS010	95	95	65SS010
20'	18.5	13.4	25SS020	31.3	22.7	45SS020	95	71	45SR020	56	42	55SS020	95	95	65SS020
30'	7.9	4.1	25SS030	16.1	8.4	45SS030	87	58	45SR030	34	21	55SS030	95	71	65SS030
35'	4.4	1.2	25SS035	9.8	3.8	45SS035	76	52	45SR035	25	14	55SS035	80	54	65SS035
40'	1.3	-	25SS040	4.9	-	45SS040	60	40	45SR040	17	8	55SS040	62	41	65SS040
45'				0.7	-	45SS045	48	31	45SR045	11	3	55SS045	48	30	65SS045
50'							38	23	45SR050	5	-	55SS050	37	21	65SS050
55'							29	16	45SR055				28	14	65SS055
60'							22	11	45SR060				20	7	65SS060

100 MPH
3-Second Gust

100 MPH 3-Second Gust Wind Speed															
Height	25G			45G			45GSR			55G			65G		
	EPA		Part No.	EPA		Part No.	EPA		Part No.	EPA		Part No.	EPA		Part No.
	Exp.B	Exp.C		Exp.B	Exp.C		Exp.B	Exp.C		Exp.B	Exp.C		Exp.B	Exp.C	
10'	20.7	16.4	25SS010	47.4	39.5	45SS010	82	66	45SR010	78	63	55SS010	95	95	65SS010
20'	14.0	9.9	25SS020	23.2	16.9	45SS020	74	55	45SR020	43	32	55SS020	95	95	65SS020
30'	5.3	2.2	25SS030	9.7	4.8	45SS030	66	43	45SR030	24	14	55SS030	81	55	65SS030
35'	2.1	-	25SS035	5.1	0.7	45SS035	59	38	45SR035	17	8	55SS035	61	40	65SS035
40'				1.2	-	45SS040	46	30	45SR040	10	3	55SS040	47	29	65SS040
45'							35	22	45SR045	5	-	55SS045	35	20	65SS045
50'							27	15	45SR050				26	13	65SS050
55'							20	9	45SR055				17	6	65SS055
60'							13	4	45SR060				11	1	65SS060

110 MPH
3-Second Gust

110 MPH 3-Second Gust Wind Speed															
Height	25G			45G			45GSR			55G			65G		
	EPA		Part No.	EPA		Part No.	EPA		Part No.	EPA		Part No.	EPA		Part No.
	Exp.B	Exp.C		Exp.B	Exp.C		Exp.B	Exp.C		Exp.B	Exp.C		Exp.B	Exp.C	
10'	16.5	12.7	25SS010	39.4	31.9	45SS010	67	53	45SR010	63	51	55SS010	95	95	65SS010
20'	10.6	7.2	25SS020	18.3	12.3	45SS020	59	43	45SR020	34	25	55SS020	95	81	65SS020
30'	3.1	0.4	25SS030	6.5	1.9	45SS030	51	32	45SR030	17	9	55SS030	65	43	65SS030
35'				1.7	-	45SS035	45	27	45SR035	11	4	55SS035	48	30	65SS035
40'							35	22	45SR040	5	-	55SS040	35	21	65SS040
45'							26	15	45SR045				25	13	65SS045
50'							19	9	45SR050				17	7	65SS050
55'							13	4	45SR055				10	-	65SS055
60'							7	-	45SR060				4	-	65SS060

Note: Antenna areas, ft.², assume all round antenna members.

NOICE

SELF-SUPPORTING G-SERIES FOUNDATIONS

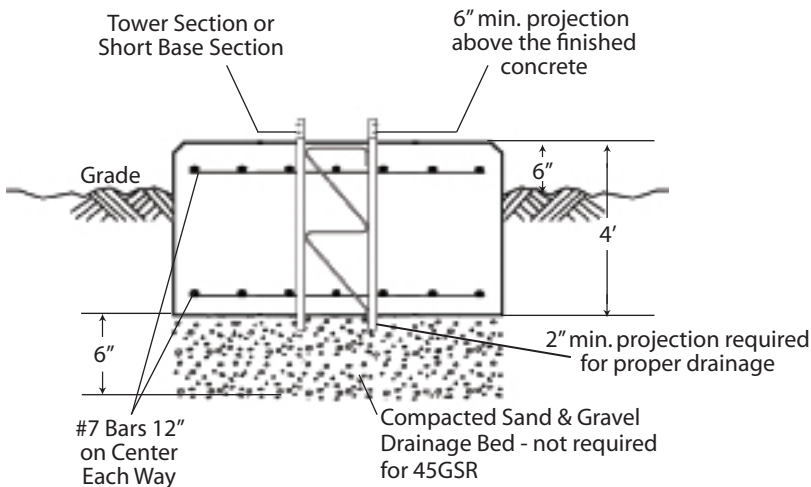

ELEVATION VIEW
25G (shown), 45G & 55G
SELF-SUPPORTING TOWER FOUNDATION

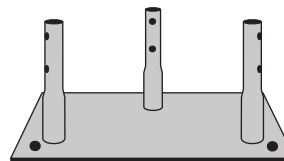

CONCRETE BASE PLATE WITH ANCHORS
25GSSB

FOR USE WITH SELF-SUPPORTING 25G TOWERS.

ALTERNATIVE TO USING SHORT BASE. BASE BOLTS & TEMPLATE MUST BE ORDERED SEPARATELY.

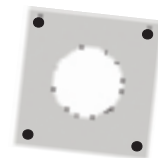

BASE BOLTS & TEMPLATE
KH8175A

FOR USE WITH 25GSSB IN SELF-SUPPORTING 25G TOWER APPLICATIONS. KIT INCLUDES (1) TEMPLATE & (4) BASE BOLTS.

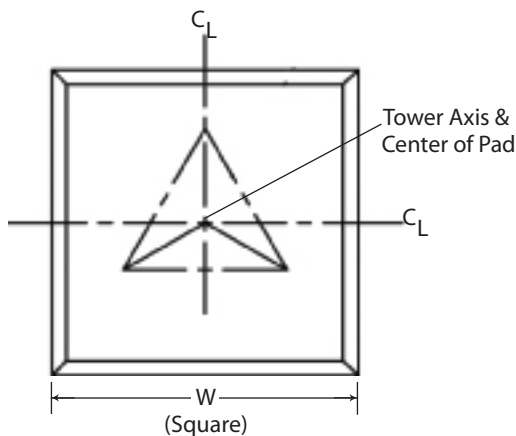

PLAN VIEW

Tower	Mat Width (W)	Concrete Volume (Cu. Yds.)
25G	4' - 0"	2.4
45G	5' - 3"	4.1
55G	6' - 0"	5.3
45GSR 65G	7' - 9"	8.9

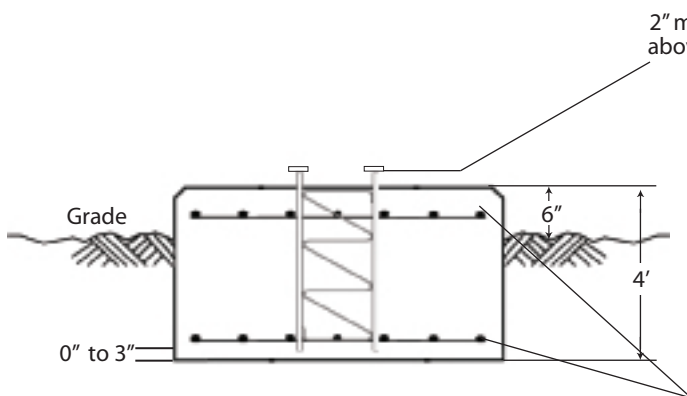

ELEVATION VIEW
45GSR
SELF-SUPPORTING TOWER FOUNDATION

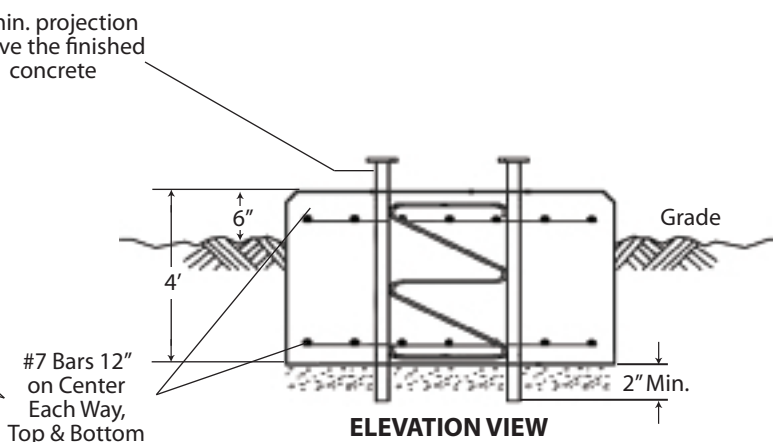

ELEVATION VIEW
65G
SELF-SUPPORTING TOWER FOUNDATION



SELF-SUPPORTING G-SERIES DESIGN NOTES

1. Tower designs are in accordance with approved national standard ANSI/EIA-222-F and ANSI/TIA-222G, Structure Class I, Exposures B and C, Topographic Category I.
2. All towers must have "fixed" bases. Pinned bases may not be used.
3. Designs assume transmission lines symmetrically placed as follows:
 - 25G Tower - One 5/8" Line on each face (Total =3)
 - 45G Tower - One 7/8" Line and one 1/2" line on each face (Total = 3 @ 7/8" & 3 @ 1/2")
 - 55G & 65G Towers - Two 7/8" Lines on each face (Total =6)
4. Antennas and mounts assumed symmetrically placed at tower apex.
5. Rev F tabulated allowable antenna areas assume all round antenna members.
6. Allowable flat-plate antenna areas, based on EIA RS-222-C, may be obtained by multiplying Rev. F Antenna areas shown by 0.6.
7. Standard foundation designs are based on Rev. F normal soil and Rev. G presumptive clay soil parameters.

Refer to pages 147-153 for General Installation and Foundation Notes.

NOTES

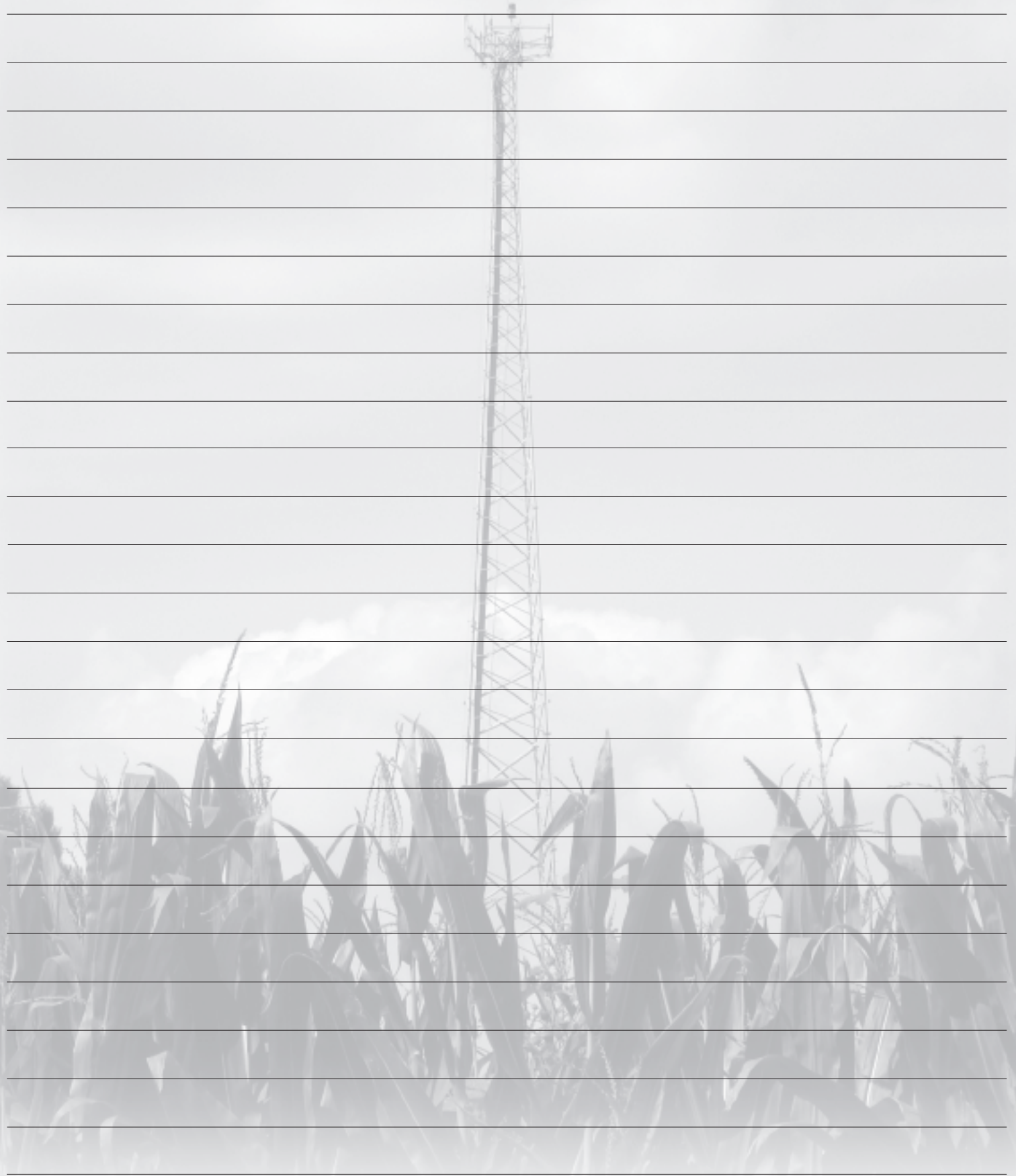

A tall, slender lattice tower stands in the center of a cornfield. The tower is made of metal and has a platform at the top. The corn plants are in the foreground, and the sky is cloudy. The entire image is overlaid with horizontal lines for writing notes.



STANDARD 65G SELF-SUPPORTING CAMERA TOWERS (all-welded)

REV. G: 110 MPH 3-SEC GUST WIND SPEED (NO ICE),
40 MPH 3-SEC GUST WIND SPEED (3/4" ICE),
CLASS II, EXPOSURE C, TOPO CATEGORY 1
SEISMIC COEFFICIENT $S_s \leq 1.0$

Tower Height	Max. Tip Deflection at 60 MPH
10'	0.10"
20'	0.10"
30'	0.40"
40'	1.00"
50'	1.80"

Maximum Load at Top		
Tower Heights	EPA	EPA
	No Ice	With Ice
10' - 40'	14.5 ft. ²	29.0 ft. ²
50'	7.0 ft. ²	14.0 ft. ²

ALL WELDED

24 1/4" Face Width (TYP)

Standard 65G Section (TYP)

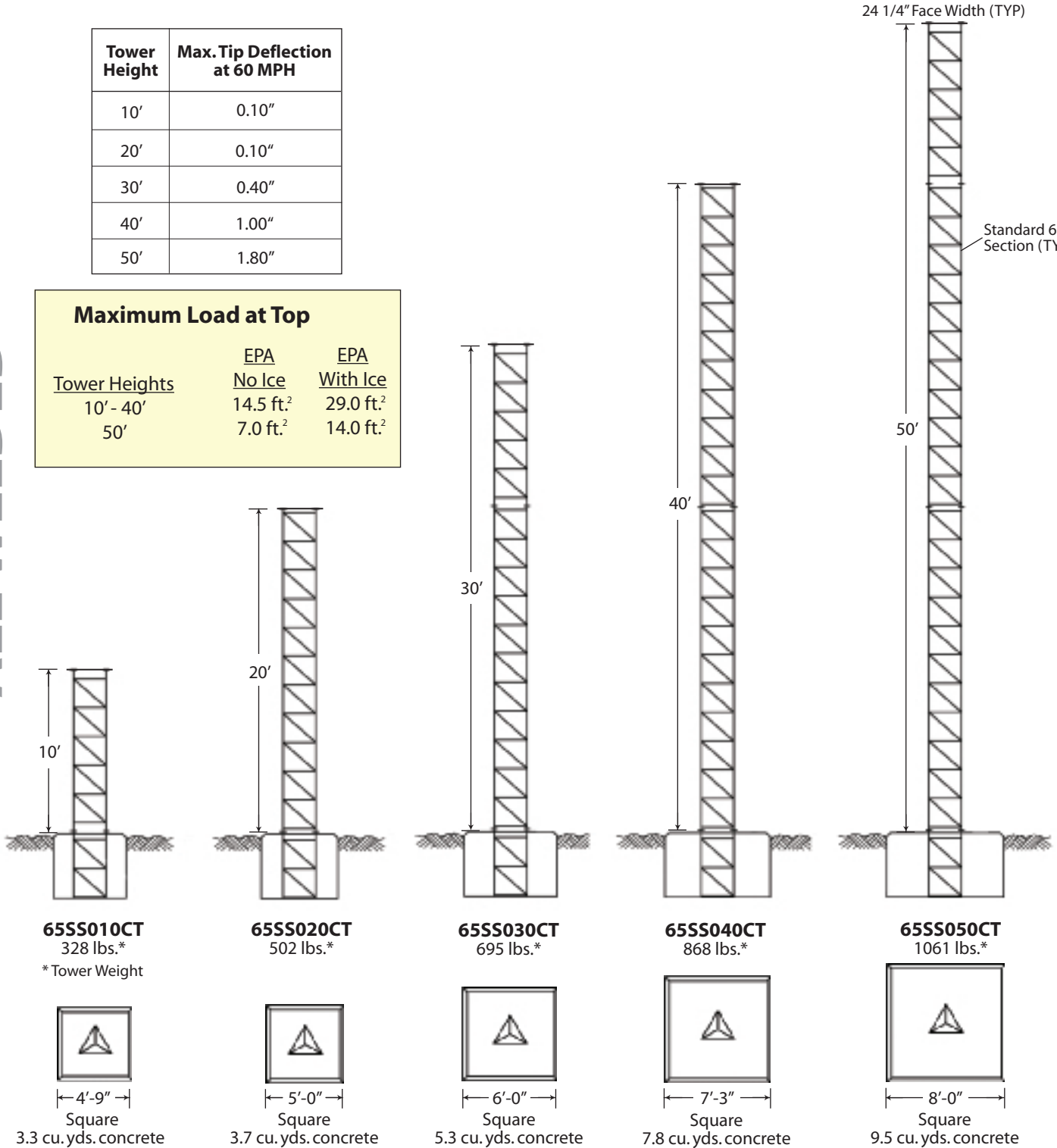

Includes short base section, tower sections, Rev G grounding material and 3/16" top mounting plate with attachment hardware.
Per Rev. G requirements, any structure greater than 10' requires a climber safety device.
Please see page 173 for ordering information.

65G CAMERA TOWERS STANDARD FOUNDATION DETAILS

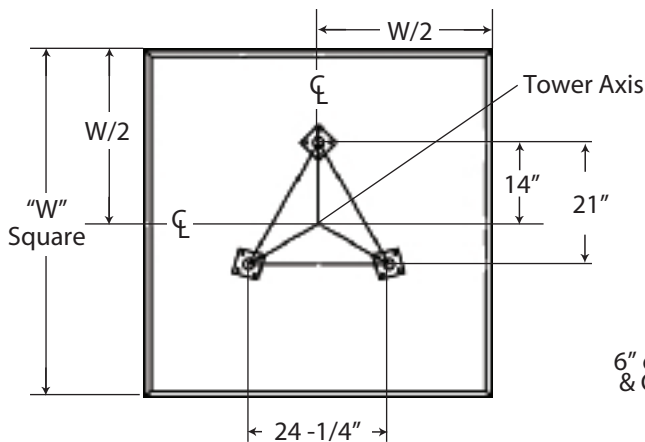

See tower elevation page for "W" dimension.

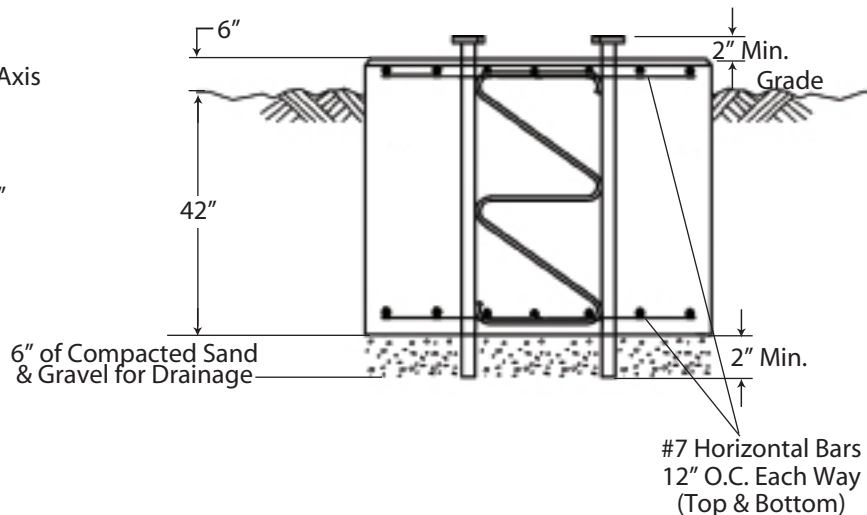

#7 Horizontal Bars
12" O.C. Each Way
(Top & Bottom)

ACCESSORIES

 <p>ANTI-CLIMB PANELS VW915A ORDERED SEPARATELY</p>	 <p>CLIMBING HARNESS TTFBH-4D JOURNEYMAN HARNESS TTFBH-C/P PROFESSIONAL HARNESS</p>	 <p>SAFETY CABLE SLIDER WITH CARABINEER TT-WG-500-W/SMC</p>	<p>SAFETY CABLE SYSTEM TT05065 FITS ALL TOWER HEIGHTS</p>
-------------------------------------------------------------------------------------------------------------------------------------------------------	-----------------------------------------------------------------------------------------------------------------------------------------------------------------------------------------------	------------------------------------------------------------------------------------------------------------------------------------------------------------	--------------------------------------------------------------------------

GENERAL NOTES

1. Tower designs are in accordance with ANSI/TIA/222-G.
2. Camera and mount assumed symmetrically placed at tower top.
3. Tower design assumes one 7/8" line on each tower face.
4. Assembly drawings and standard foundation details are provided with the tower.
5. Standard foundation illustrated is for general information only and is based on Rev G presumptive clay soil parameters.



STANDARD VG SELF-SUPPORTING CAMERA TOWERS (field bolted)

REV. G: 110 MPH 3-SEC GUST WIND SPEED (NO ICE), 40 MPH 3-SEC GUST WIND SPEED (3/4" ICE), CLASS II, EXPOSURE C, TOPO CATEGORY 1 SEISMIC COEFFICIENT S_s ≤ 1.0

Tower Height	Max. Tip Deflection at 60 MPH
10'	0.10"
20'	0.10"
30'	0.20"
40'	0.70"
50'	1.30"

Maximum Load at Top		
Tower Heights	EPA	EPA
	No Ice	With Ice
10' - 40'	14.5 ft. ²	29.0 ft. ²
50'	7.0 ft. ²	14.0 ft. ²

KNOCKED DOWN

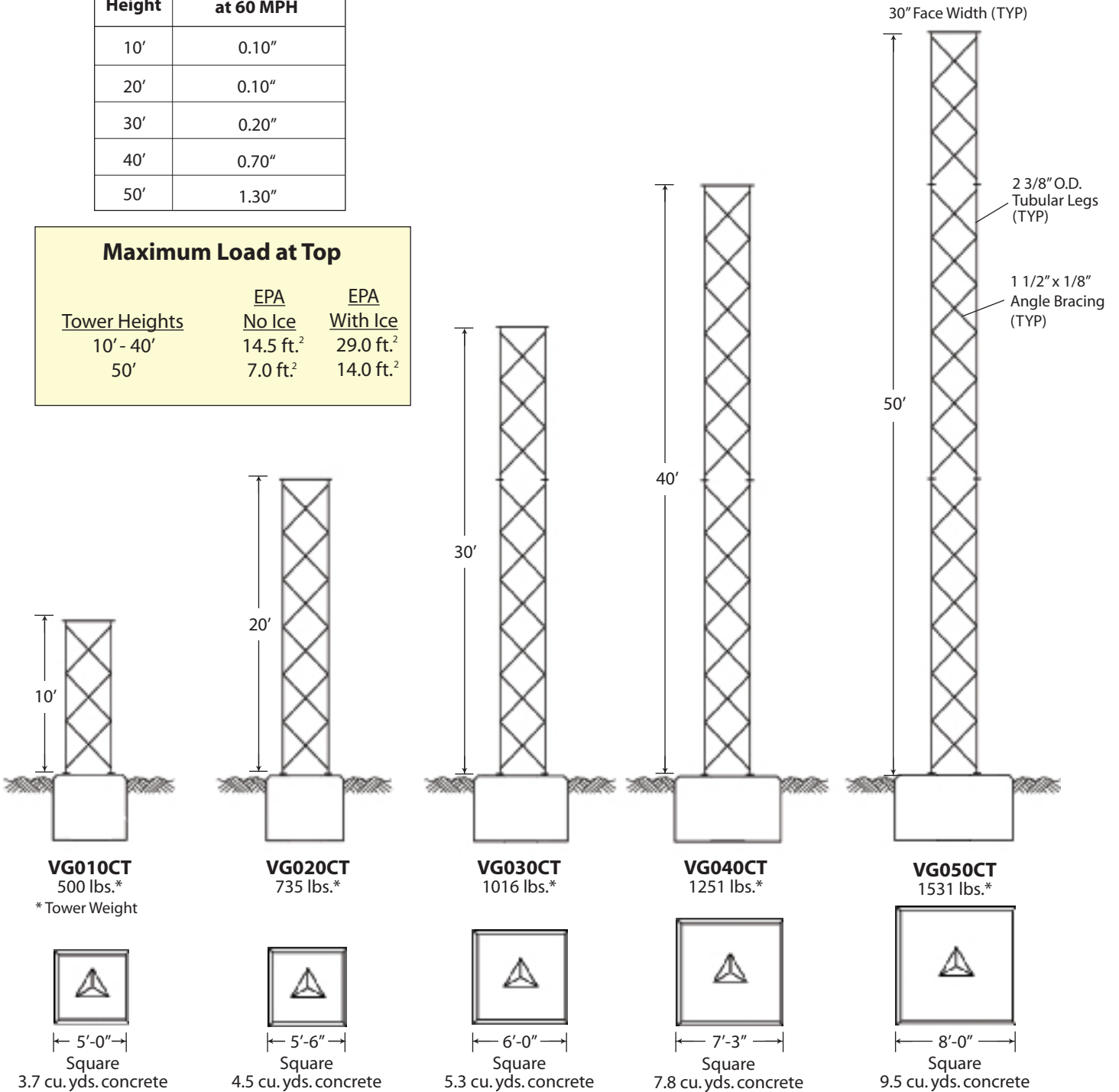

Includes anchor bolts, templates, tower sections, Rev G grounding material, 1/2" top mounting plate with attachment hardware and step bolts.

Per Rev. G requirements, any structure greater than 10' requires a climber safety device.

See page 175 for ordering information.

VG CAMERA TOWERS STANDARD FOUNDATION DETAILS

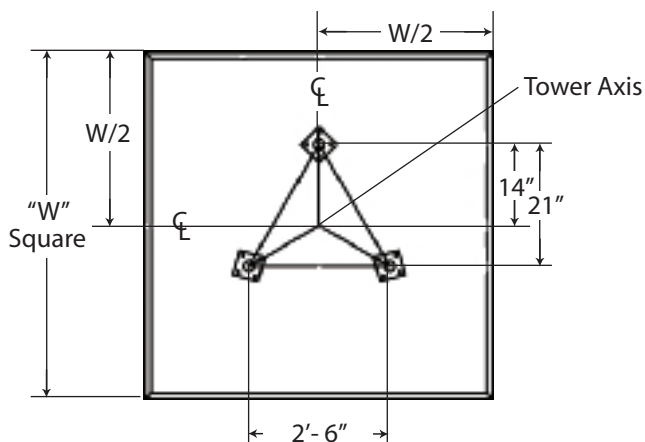

See tower elevation page for "W" dimensions.

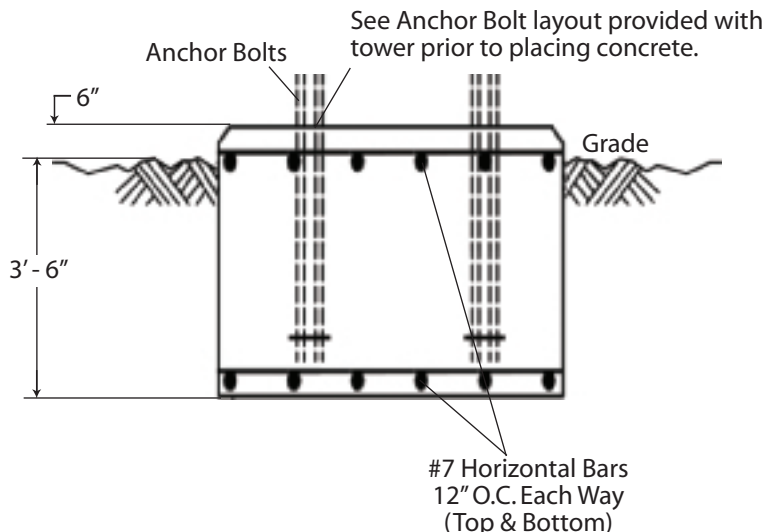

ACCESSORIES

 <p>ANTI-CLIMB PANELS VW917A ORDERED SEPARATELY</p>	 <p>CLIMBING HARNESS TTFBH-4D JOURNEYMAN HARNESS TTFBH-C/P PROFESSIONAL HARNESS</p>	 <p>SAFETY CABLE SLIDER WITH CARABINEER TT-WG-500-W/SMC</p>	<p>SAFETY CABLE SYSTEM TT050SSL FITS ALL TOWER HEIGHTS</p>
-------------------------------------------------------------------------------------------------------------------------------------------------------	-----------------------------------------------------------------------------------------------------------------------------------------------------------------------------------------------	------------------------------------------------------------------------------------------------------------------------------------------------------------	---------------------------------------------------------------------------

GENERAL NOTES

1. Tower designs are in accordance with ANSI/TIA/222-G.
2. Camera and mount assumed symmetrically placed at tower top.
3. Tower design assumes one 7/8" line on each tower face.
4. Assembly drawings and standard foundation details are provided with the tower.
5. Standard foundation illustrated is for general information only and is based on Rev G presumptive clay soil parameters.

Refer to pages 147-153 for Foundation General Notes.

STANDARD RSL SELF-SUPPORTING TOWERS (field bolted)

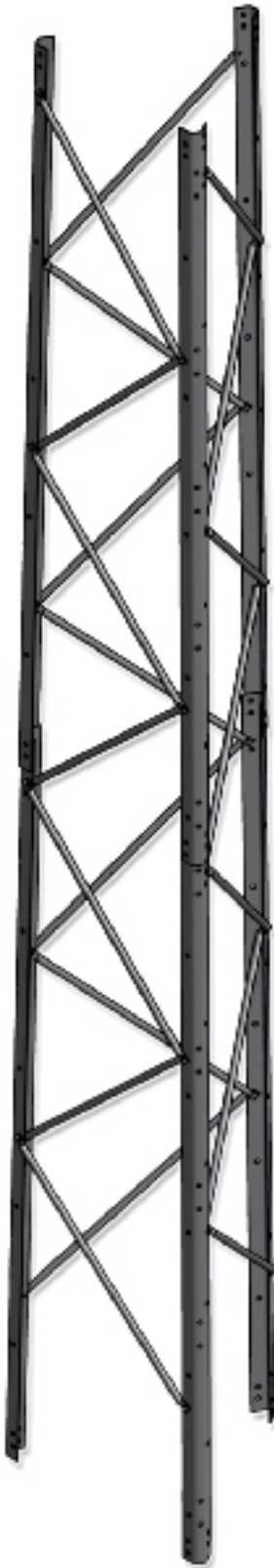

The all new RSL

COMPLETELY REDESIGNED

GENERAL USE

The ROHN RSL is a light weight self-supporting tower designed for use in broadband, public safety and security applications. The RSL reaches above line-of-site obstacles such as tree tops, hilly terrain and buildings. The RSL is shipped knocked down to reduce shipping cost and time.

FEATURES

- Available in heights from 20' up to 100'
- U-shaped legs allows for simple lap splice connection
- Available in standard and heavy models
- Pre-punched holes for attachment of safety climb systems, mounting kits, etc.
- Braces for each section are the same length, while bolt lengths are standard throughout the tower
- Tower material is hot-dip galvanized
- Assembly drawings provided with tower
- Top closing angle standard with each tower package

Optional items are available and may be ordered separately:

- Step Bolts
- Safety Climbing System*
- Top Post
- Anti-Climb Brackets
- Multiple Mounting Kits
- Grounding kit
- Top Plate
- Accessory Shelf
- Waveguide Brackets
- Lightning Rod

For more information, please visit our website: www.rohnnet.com

**Per Rev G requirements, any structure greater than 10' requires a climber safety device.*

ORDERING INFO

1. Foundation bases must be ordered separately.
2. All accessories must be ordered separately including step bolt kits, safety climb systems, climbing harness with slider, grounding kits, lightning rods, top plate, top mast, mounting kits, W/G brackets, anti-climb assemblies, etc.
3. ROHN standard RSL tower kits are supplied with lock washers as nut locking devices. Pal nuts (P), anco nuts (A) and tri-loc nuts (T) are alternative nut locking devices that may be obtained by adding the indicated suffix to the standard RSL tower kit Part Number. (Note: nut locking devices are required in accordance with ANSI/TIA-222-G.) *Example: RSL100L10A for Anco Nuts.*
4. All three tower legs in each section have provision to install step bolts and a safety climb system. When step bolts are desired, one step bolt kit must be ordered for each section of the tower. Increase the number of step bolt kits accordingly when step bolts are desired on more than one tower leg of a section.

DESIGN NOTES

1. The suitability of a ROHN standard RSL tower kit and standard foundation for a specific application must be verified by the purchaser based on site-specific data in accordance with the ANSI/TIA-222-G Standard. All users are solely responsible for the installation, use, maintenance, inspection and other work and the compliance with all local, state and federal requirements.
2. The allowable Effective Projected Areas (EPA) tabulated for the standard RSL tower kits represent the summation of the projected areas of all antennas, mounts and accessories multiplied by appropriate drag factors. The tabulated EPA values are in addition to the loading from a 3/8 inch diameter safety cable assumed to be mounted to each standard tower. The tabulated EPA values are for a no-ice condition. For design purposes, the tabulated EPA values have been increased 75% when investigating extreme ice loading conditions.
3. The tabulated EPA values apply to towers located on sites with level grade (ANSI/TIA-222-G Topographic Category 1). Lower EPA values than tabulated would apply for roof mounted towers or for towers located on sites with unusual terrain. Contact ROHN for site-specific design limitations.
4. The RSL standard designs are based on one 1/2 inch transmission line for each 10 square feet of EPA up to a maximum of 6 lines unless otherwise noted. All lines are assumed to be symmetrically mounted on the tower faces adjacent to a leg.
5. The total weight of all antennas and mounts associated with the tabulated EPA values is assumed to equal 500 pounds for the no-ice condition and 1000 pounds for the extreme ice condition.
6. The tabulated EPA values assume the associated antennas and appurtenances are symmetrically mounted unless otherwise noted. Eccentric loading may increase member forces and may require a reduction of the tabulated EPA values. Mounting arrangements are assumed to be appropriate for the supporting members utilized. Contact ROHN if assistance is needed in determining the adequacy of a specific RSL tower kit for site-specific loading conditions.
7. The RSL standard top mast is designed to support a maximum EPA of 5 square feet with 100 pounds vertical load. Other optional top mounts are available upon request. All other loading is assumed to be mounted to the tower below the top mast.
8. The standard RSL tower kits that include dish loading criteria meet ANSI/TIA-222-G twist and sway requirements for a 6 GHz dish frequency. All dishes are assumed to be face mounted. Contact ROHN for assistance with higher frequency or other mounting arrangement applications.

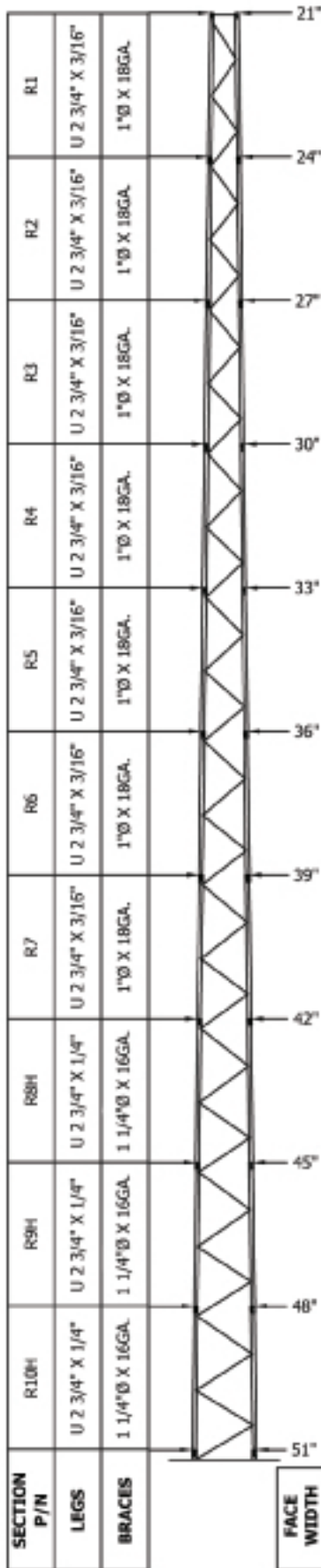

RSL TOWER DESIGN LOADING ACCORDING TO ANSI/TIA-222-G								
STRUCTURE CLASSIFICATION = I								
EXPOSURE CATEGORY = B								
TOPOGRAPHIC CATEGORY = 1								
RSL-D01 R4								
HEIGHT (FT)	SECTIONS	TOWER KIT P/N	ALLOWABLE EFFECTIVE PROJECTED AREA (FT ²)					
			3-SECOND GUST WIND SPEED (MPH)					
			90	100	110	120	130	140
100	R1 - R10H	RSL100L10	25	11	-	-	-	-
90	R1 - R9H	RSL90L19	31	20	10	-	-	-
	R2 - R10H	RSL90L20	39	23	12	4	-	-
80	R1 - R8H	RSL80L18	34	21	12	4	-	-
	R2 - R9H	RSL80L29	49	34	22	10	-	-
	R3 - R10H	RSL80L30	56	38	25	14	4	-
70	R1 - R7	RSL70L17	40	27	17	9	-	-
	R2 - R8H	RSL70L28	52	37	25	13	-	-
	R3 - R9H	RSL70L39	74	52	32	19	8	-
	R4 - R10H	RSL70L40	80	56	38	24	13	5
60	R1 - R6	RSL60L16	59	42	30	21	12	-
	R4 - R9H	RSL60L49	80	62	42	28	17	9
	R5 - R10H	RSL60L50	80	67	48	34	24	15
50	R1 - R5	RSL50L15	80	60	45	34	26	19
	R5 - R9H	RSL50L59	80	73	53	38	27	19
	R6 - R10H	RSL50L60	80	78	59	45	35	27
40	R1 - R4	RSL40L14	80	80	67	52	42	31
	R7 - R10H	RSL40L70	80	80	72	58	48	39
30	R1 - R3	RSL30L13	80	80	80	71	57	45
	R8H - R10H	RSL30H80	80	80	80	80	80	80
20	R1 - R2	RSL20L12	80	80	80	71	60	49
	R9H - R10H	RSL20H90	80	80	80	80	80	80

The tabulated allowable effective projected areas (EPA) are limited to a maximum recommended value of 80 (ft²). EPA values shown as " - " indicate tower kit is not applicable for the corresponding wind speed.

Site-specific designs are available upon request.

TUBE BRACING
CLASS I LOADING

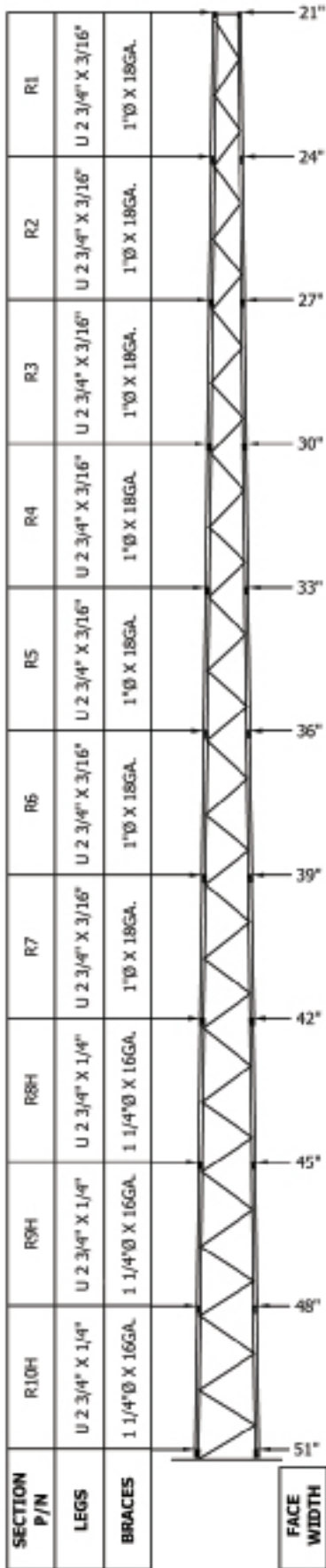

RSL TOWER DESIGN LOADING ACCORDING TO ANSI/TIA-222-G								
STRUCTURE CLASSIFICATION = II EXPOSURE CATEGORY = C TOPOGRAPHIC CATEGORY = 1 3-SECOND GUST WIND SPEED WITH ICE = 40 MPH DESIGN ICE THICKNESS = 1.0" EARTHQUAKE SPECTRAL RESPONSE ACCELERATION, $S_s = 2.50$								
HEIGHT (FT)	SECTIONS	TOWER KIT P/N	ALLOWABLE EFFECTIVE PROJECTED AREA (FT ²) 3-SECOND GUST WIND SPEED WITHOUT ICE (MPH)					
			90	100	110	120	130	140
90	R1 - R9H	RSL90L19	10	-	-	-	-	-
	R2 - R10H	RSL90L20	11	-	-	-	-	-
80	R1 - R8H	RSL80L18	11	-	-	-	-	-
	R2 - R9H	RSL80L29	21	4	-	-	-	-
	R3 - R10H	RSL80L30	24	10	-	-	-	-
70	R1 - R7	RSL70L17	15	6	-	-	-	-
	R2 - R8H	RSL70L28	24	10	-	-	-	-
	R3 - R9H	RSL70L39	30	12	-	-	-	-
	R4 - R10H	RSL70L40	35	20	8	-	-	-
60	R1 - R6	RSL60L16	29	18	8	-	-	-
	R4 - R9H	RSL60L49	39	22	10	-	-	-
	R5 - R10H	RSL60L50	45	30	18	9	-	-
50	R1 - R5	RSL50L15	43	30	20	10	-	-
	R5 - R9H	RSL50L59	49	32	20	11	4	-
	R6 - R10H	RSL50L60	56	40	29	20	13	8
40	R1 - R4	RSL40L14	62	47	35	24	14	7
	R7 - R10H	RSL40L70	67	52	40	32	25	20
30	R1 - R3	RSL30L13	79	63	48	36	27	19
	R8H - R10H	RSL30H80	80	80	80	73	56	43
20	R1 - R2	RSL20L12	80	69	57	45	36	29
	R9H - R10H	RSL20H90	80	80	80	80	73	59

The tabulated allowable effective projected areas (EPA) are limited to a maximum recommended value of 80 (ft²). EPA values shown as " - " indicate tower kit is not applicable for the corresponding wind speed.

Site-specific designs are available upon request.

TUBE BRACING
CLASS II LOADING

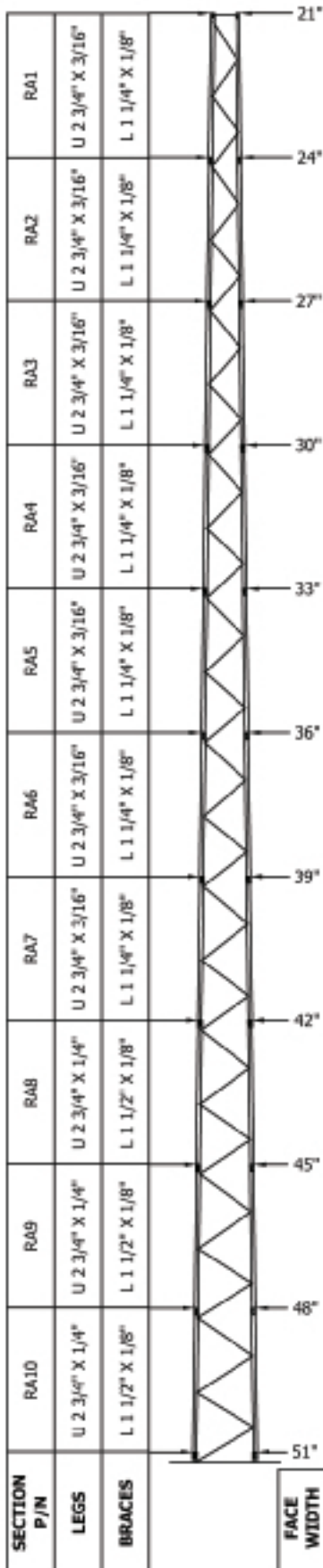

RSL TOWER DESIGN LOADING ACCORDING TO ANSI/TIA-222-G								
STRUCTURE CLASSIFICATION = I								
EXPOSURE CATEGORY = B								
TOPOGRAPHIC CATEGORY = 1								
RSL-D03 R3								
HEIGHT (FT)	SECTIONS	TOWER KIT P/N	ALLOWABLE EFFECTIVE PROJECTED AREA (FT ²)					
			3-SECOND GUST WIND SPEED (MPH)					
			90	100	110	120	130	140
100	RA1 - RA10	RSL100A10	20	9	-	-	-	-
	RA1 - RA9	RSL90A19	30	17	7	-	-	-
90	RA2 - RA10	RSL90A20	35	20	9	-	-	-
	RA1 - RA8	RSL80A18	31	20	9	-	-	-
80	RA2 - RA9	RSL80A29	47	31	20	9	-	-
	RA3 - RA10	RSL80A30	52	34	21	11	-	-
	RA1 - RA7	RSL70A17	38	24	13	5	-	-
70	RA2 - RA8	RSL70A28	50	34	23	12	-	-
	RA3 - RA9	RSL70A39	71	50	34	19	6	-
	RA4 - RA10	RSL70A40	77	53	38	25	11	-
	RA1 - RA6	RSL60A16	57	40	29	18	-	-
60	RA4 - RA9	RSL60A49	80	67	45	30	17	7
	RA5 - RA10	RSL60A50	80	71	51	36	23	9
	RA1 - RA5	RSL50A15	79	58	44	33	24	17
50	RA5 - RA9	RSL50A59	80	78	56	40	29	19
	RA6 - RA10	RSL50A60	80	80	64	49	34	20
	RA1 - RA4	RSL40A14	80	80	65	51	40	32
40	RA7 - RA10	RSL40A70	80	80	78	63	48	33
	RA1 - RA3	RSL30A13	80	80	80	80	66	54
30	RA8 - RA10	RSL30A80	80	80	80	80	64	49
	RA1 - RA2	RSL20A12	80	80	80	80	80	69
20	RA9 - RA10	RSL20A90	80	80	80	80	77	62

The tabulated allowable effective projected areas (EPA) are limited to a maximum recommended value of 80 (ft²). EPA values shown as " - " indicate tower kit is not applicable for the corresponding wind speed.

Site-specific designs are available upon request.

ANGLE BRACING
CLASS I LOADING

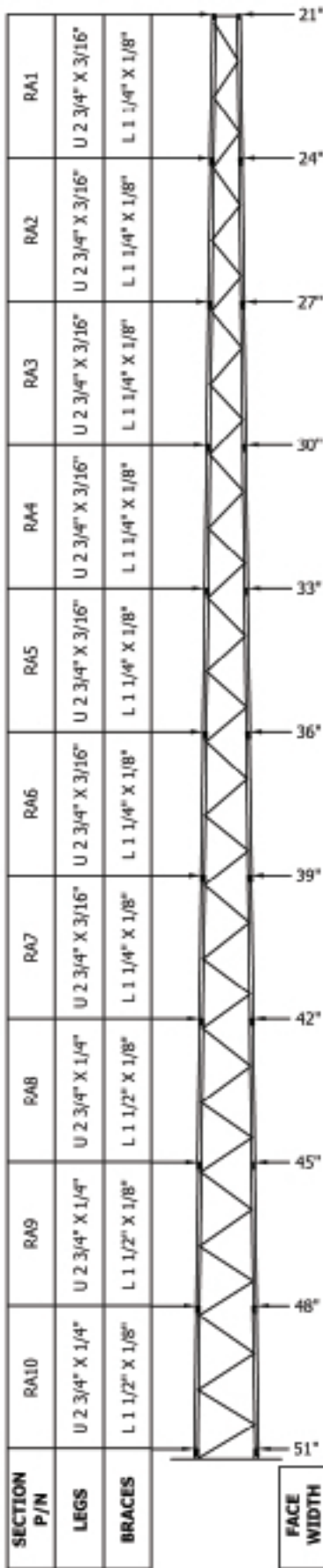

RSL TOWER DESIGN LOADING ACCORDING TO ANSI/TIA-222-G								
STRUCTURE CLASSIFICATION = II EXPOSURE CATEGORY = C TOPOGRAPHIC CATEGORY = 1 3-SECOND GUST WIND SPEED WITH ICE = 40 MPH DESIGN ICE THICKNESS = 1.0" EARTHQUAKE SPECTRAL RESPONSE ACCELERATION, S _s = 2.50								
HEIGHT (FT)	SECTIONS	TOWER KIT P/N	ALLOWABLE EFFECTIVE PROJECTED AREA (FT ²)					
			3-SECOND GUST WIND SPEED WITHOUT ICE (MPH)					
			90	100	110	120	130	140
90	RA1 - RA9	RSL90A19	6	-	-	-	-	-
	RA2 - RA10	RSL90A20	8	-	-	-	-	-
80	RA1 - RA8	RSL80A18	8	-	-	-	-	-
	RA2 - RA9	RSL80A29	19	-	-	-	-	-
	RA3 - RA10	RSL80A30	20	9	-	-	-	-
70	RA1 - RA7	RSL70A17	12	-	-	-	-	-
	RA2 - RA8	RSL70A28	21	7	-	-	-	-
	RA3 - RA9	RSL70A39	30	12	-	-	-	-
	RA4 - RA10	RSL70A40	36	20	-	-	-	-
60	RA1 - RA6	RSL60A16	26	14	-	-	-	-
	RA4 - RA9	RSL60A49	40	23	10	-	-	-
	RA5 - RA10	RSL60A50	48	30	15	-	-	-
50	RA1 - RA5	RSL50A15	41	29	19	11	-	-
	RA5 - RA9	RSL50A59	52	34	21	11	-	-
	RA6 - RA10	RSL50A60	60	42	27	11	-	-
40	RA1 - RA4	RSL40A14	61	45	34	25	19	10
	RA7 - RA10	RSL40A70	73	56	39	25	13	-
30	RA1 - RA3	RSL30A13	80	72	56	45	35	26
	RA8 - RA10	RSL30A80	80	75	54	38	27	18
20	RA1 - RA2	RSL20A12	80	80	78	62	50	40
	RA9 - RA10	RSL20A90	80	80	72	56	43	33

The tabulated allowable effective projected areas (EPA) are limited to a maximum recommended value of 80 (ft²). EPA values shown as "-" indicate tower kit is not applicable for the corresponding wind speed.

Site-specific designs are available upon request.

ANGLE BRACING
CLASS II LOADING

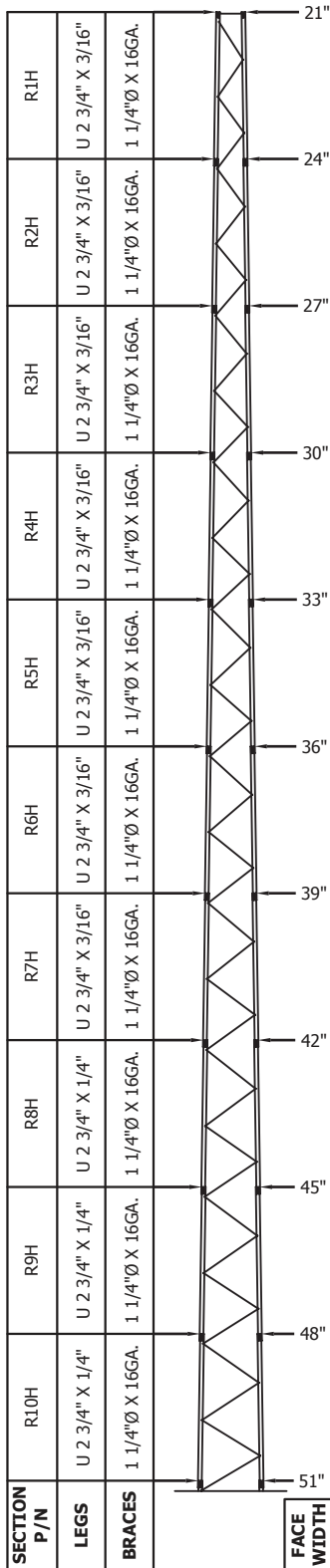

RSL TOWER DESIGN LOADING ACCORDING TO ANSI/TIA-222-G									
STRUCTURE CLASSIFICATION = II EXPOSURE CATEGORY = C TOPOGRAPHIC CATEGORY = 1 3-SECOND GUST WIND SPEED WITH ICE = 40 MPH DESIGN ICE THICKNESS = 1.0" EARTHQUAKE SPECTRAL RESPONSE ACCELERATION, S _s = 2.50									
HEIGHT (FT)	SECTIONS	HIGH PERFORMANCE DISH LOCATED 10 FT BELOW TOWER TOP	TOWER KIT P/N	ALLOWABLE EFFECTIVE PROJECTED AREA (FT ²)					
				3-SECOND GUST WIND SPEED WITHOUT ICE (MPH)					
				90	100	110	120	130	140
90	R1H - R9H	HP2	RSL90H19	5	-	-	-	-	-
	R2H - R10H	HP2	RSL90H20	7	-	-	-	-	-
80	R1H - R8H	HP2	RSL80H18	7	-	-	-	-	-
	R2H - R9H	HP2	RSL80H29	17	6	-	-	-	-
	R3H - R10H	HP4	RSL80H30	10	-	-	-	-	-
70	R1H - R7H	HP2	RSL70H17	10	-	-	-	-	-
	R2H - R8H	HP2	RSL70H28	20	10	-	-	-	-
	R3H - R9H	HP2	RSL70H39	31	19	9	-	-	-
	R4H - R10H	HP4	RSL70H40	27	12	-	-	-	-
60	R1H - R6H	HP2	RSL60H16	25	13	5	-	-	-
	R4H - R9H	HP4	RSL60H49	43	27	15	6	-	-
	R5H - R10H	HP4	RSL60H50	48	30	18	8	-	-
50	R1H - R5H	HP4	RSL50H15	31	18	8	-	-	-
	R5H - R9H	HP4	RSL50H59	72	50	35	23	14	7
	R6H - R10H	HP4	RSL50H60	78	55	39	26	11	-
40	R1H - R4H	HP4	RSL40H14	51	36	25	16	8	-
	R7H - R10H	HP4	RSL40H70	80	80	59	39	23	11
30	R1H - R3H	HP4	RSL30H13	80	63	48	37	28	20
	R8H - R10H	HP4	RSL30H80	80	80	74	53	37	24
20	R1H - R2H	HP4	RSL20H12	80	80	80	75	61	48
	R9H - R10H	HP4	RSL20H90	80	80	80	69	52	39

The tabulated allowable effective projected areas (EPA) are limited to a maximum recommended value of 80 (ft²). EPA values shown in the table are in addition to the specified high performance dish. EPA values shown as " - " indicate tower kit is not applicable for the corresponding wind speed.

**HEAVY TUBE BRACING
DISH LOADING**

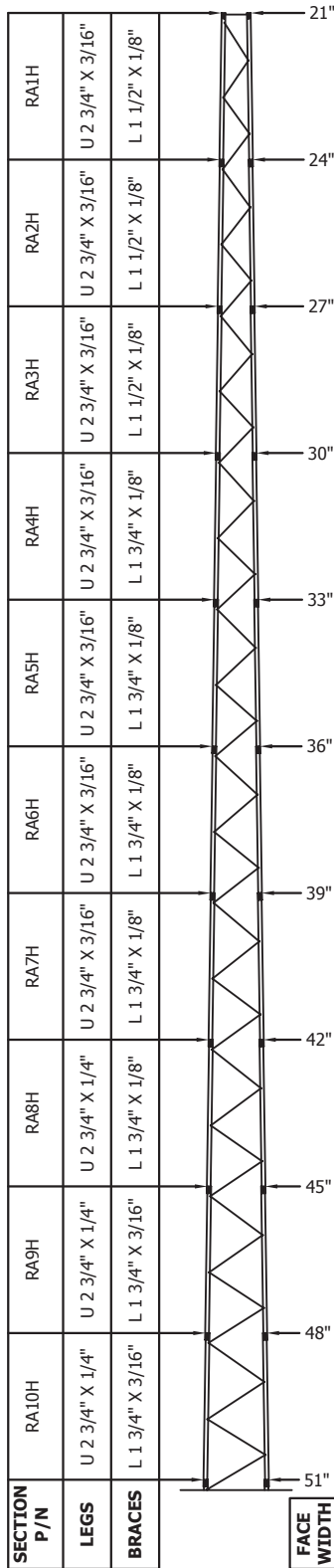





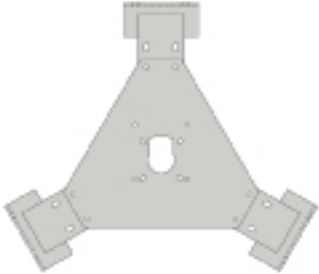

RSL TOWER DESIGN LOADING ACCORDING TO ANSI/TIA-222-G									
STRUCTURE CLASSIFICATION = II EXPOSURE CATEGORY = C TOPOGRAPHIC CATEGORY = 1 3-SECOND GUST WIND SPEED WITH ICE = 40 MPH DESIGN ICE THICKNESS = 1.0" EARTHQUAKE SPECTRAL RESPONSE ACCELERATION, S _s = 2.50									
HEIGHT (FT)	SECTIONS	HIGH PERFORMANCE DISH LOCATED 10 FT BELOW TOWER TOP	TOWER KIT P/N	ALLOWABLE EFFECTIVE PROJECTED AREA (FT ²)					
				3-SECOND GUST WIND SPEED WITHOUT ICE (MPH)					
				90	100	110	120	130	140
90	RA2H - RA10H	HP2*	RSL90AH20	0	-	-	-	-	-
	RA1H - RA8H	HP2*	RSL80AH18	0	-	-	-	-	-
80	RA2H - RA9H	HP2	RSL80AH29	12	-	-	-	-	-
	RA3H - RA10H	HP4	RSL80AH30	6	-	-	-	-	-
70	RA1H - RA7H	HP2	RSL70AH17	6	-	-	-	-	-
	RA2H - RA8H	HP2	RSL70AH28	17	5	-	-	-	-
	RA3H - RA9H	HP2	RSL70AH39	28	14	4	-	-	-
60	RA4H - RA10H	HP4	RSL70AH40	21	8	-	-	-	-
	RA1H - RA6H	HP2	RSL60AH16	20	10	-	-	-	-
	RA4H - RA9H	HP4	RSL60AH49	39	22	10	-	-	-
50	RA5H - RA10H	HP4	RSL60AH50	43	26	13	-	-	-
	RA1H - RA5H	HP4	RSL50AH15	29	15	4	-	-	-
	RA5H - RA9H	HP4	RSL50AH59	68	46	31	20	10	-
40	RA6H - RA10H	HP4	RSL50AH60	74	50	34	22	12	5
	RA1H - RA4H	HP4	RSL40AH14	50	34	22	13	6	-
	RA7H - RA10H	HP4	RSL40AH70	80	80	67	50	37	27
30	RA1H - RA3H	HP4	RSL30AH13	80	62	47	35	27	20
	RA8H - RA10H	HP4	RSL30AH80	80	80	80	80	68	49
20	RA1H - RA2H	HP4	RSL20AH12	80	80	80	74	60	47
	RA9H - RA10H	HP4	RSL20AH90	80	80	80	80	80	67

The tabulated allowable effective projected areas (EPA) are limited to a maximum recommended value of 80 (ft²). EPA values shown in the table are in addition to the specified high performance dish. EPA values shown as "-" indicate tower kit is not applicable for the corresponding wind speed.

**HEAVY ANGLE BRACING
DISH LOADING**

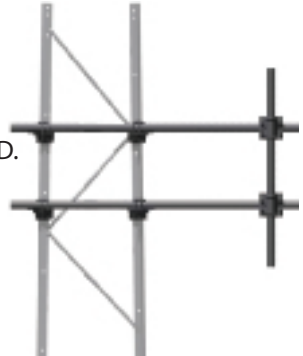
OPTIONAL ACCESSORIES

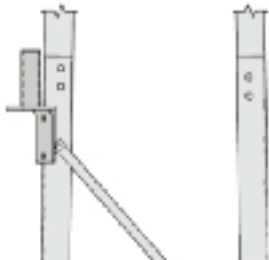
<p>TOP PLATE KIT RTP12 RTP07 RTP34 RTP08 RTP56 RTP09 Mounts to top closing angles provided with tower kit. Hole pattern fits TB3 and TB4 thrust bearings. Kit includes plate and attachment hardware.</p>	 <p>TOP MAST KIT RSLTMA 2.38" O.D. x 0.154" wall x 3' mast mounts to top plate kit. Top plate kit <i>must be ordered separately.</i></p>	<p>ACCESSORY SHELF RASK12 RASK34 RASK05 Mounts to tower legs at approximately 4' - 6" below top. Kit includes plate and attachment hardware. <i>Top plate, if required, must be ordered separately.</i></p> 
<p>LEG MOUNT RSLM-DLM Mounting pipe: 2.38" O.D. x 0.154" wall x 5' long mounting pipe.</p> 	<p>FRAME MOUNT RSLM-3FM 10' Frame mount with 1.90" O.D. x 0.145" wall x 10' horizontal pipe with 2.38" O.D. x 0.154" wall x 5' mounting pipes.</p> 	
<p>FACE MOUNT RSLM-DFML Face Mount with 2.38" O.D. x 0.154" wall x 5' long mounting pipe.</p> <p>RSLM-DFMH Face Mount with 4.5" O.D. x 0.237" wall x 5' mounting pipe.</p> 	<p>SIDE ARM MOUNT RSLM-3SA 3' Side Arm Mount with 1.90" O.D. x 0.145" wall x 8' horizontal pipe and 2.38" O.D. x 0.154" wall x 5' mounting pipe.</p> 	
<p>SINGLE ARM MOUNT RSLM-SAM 3' single arm with 1.50" O.D. x 0.120" wall x 10' horizontal pipe.</p> 	<p>LEG MOUNTED BRACKET RSLM-LMB Leg mounted bracket with a 1.90" O.D. x 0.154" wall x 6" mounting post.</p> 	

OPTIONAL ACCESSORIES

SECTOR MOUNT

RSM1 RSM3
RSM2 RSM4

Mount can accommodate up to (12) 5' mounting pipes. Brackets and U-bolts at corners are provided with this kit. Additional mounting kits (RSMBK) and pipes must be ordered separately.

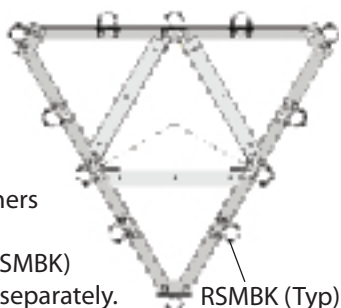

TIE BACK ASSEMBLY

RSLTBA

Dish tie back bracket. Clamps to a leg at any location. Includes (1) bracket with required mounting hardware.

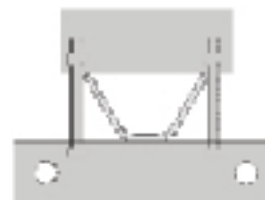

LIGHTNING ROD

LRCL

5' Copper clad, mounts to top closing angles.



WAVEGUIDE BRACKETS

RSWGB

Includes (1) 3-hole bracket with required mounting hardware. Mounts to pre-punched holes in leg.

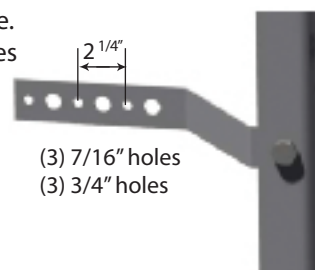

CLIMBING HARNESS

TTFBH-4D (Journeyman Harness)
TTFBH-C/P (Professional Harness)



SAFETY CABLE SLIDER WITH CARABINEER

TT-WG-500-W/SMC



STEP BOLT KIT

RSLSTEP

One kit consists of (10) 5/8" x 7" steps for one 10' tower section. Order one kit for each section of tower for step bolts on one leg.

SAFETY CABLE SYSTEMS

Tower Height	Part Number
20' - 50'	TTRSL50
60' - 100'	TTRSL100

ANTI-CLIMB BRACKETS

RACW

Brackets to be used with barbed or razor wire (wire not included). Kit includes (3) outer and (3) inner brackets with required mounting hardware.

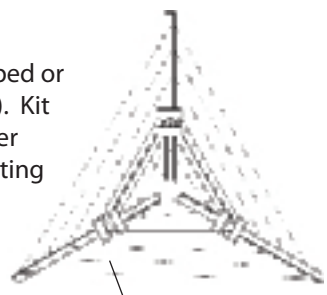

Barbed wire shown installed.

RSL GROUNDING KIT

RGKG (3 LEG KIT)
RGKG-1 (1 LEG KIT)

Grounding kit, per Rev. G, 5/8" x 10' ground rods, 7/16" IWRC stranded galvanized ground leads and clamps.

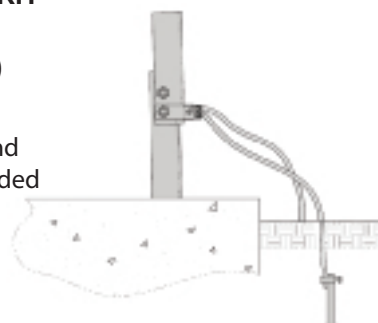

FOUNDATION INFORMATION

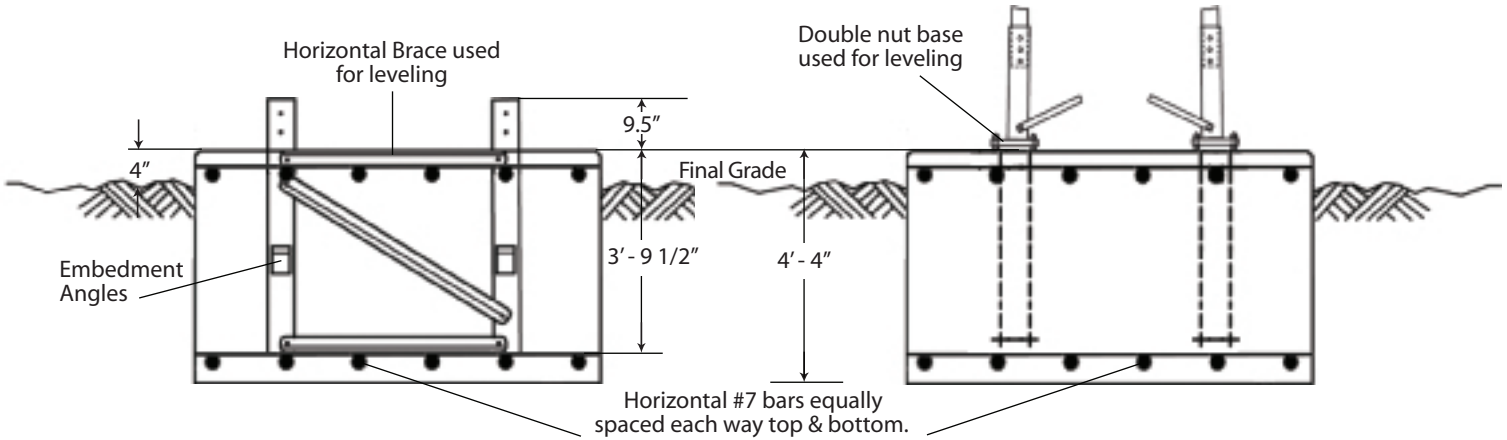

SHORT BASE

ANCHOR BASE

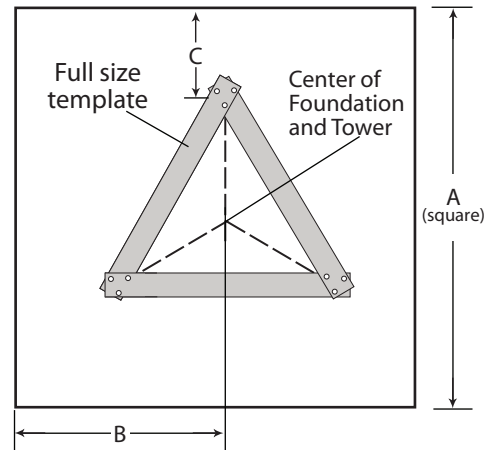
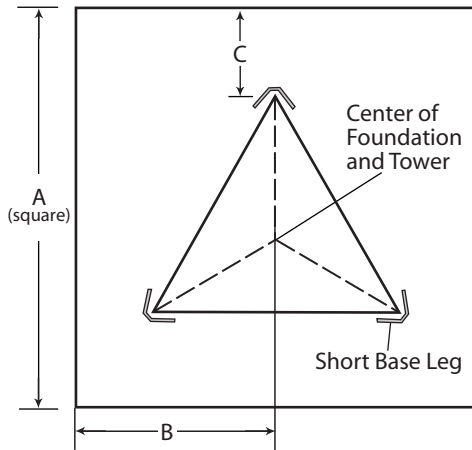

Anchor base option includes: full-size template, anchor bolt lower template, anchor bolts and leg stubs.

SHORT BASE
(Ordered separately from tower)

STANDARD FOUNDATION INFORMATION
(Used with short base and anchor base options)

ANCHOR BASE
(Ordered separately from tower)

Short Base Section
RSB02
RSB03
RSB04
RSB05
RSB06
RSB07
RSB08
RSB09
RSB10

Tower Base Section	Dimensions			Concrete (Cu. Yds)	No. 7 Bars Req.
	A	B	C		
2	7' - 6"	3' - 9"	2' - 5"	9.0	32
3	7' - 9"	3' - 10 1/2"	2' - 5"	9.6	40
4	8' - 0"	4' - 0"	2' - 5"	10.3	40
5	8' - 3"	4' - 1 1/2"	2' - 5"	10.9	40
6	8' - 6"	4' - 3"	2' - 4"	11.6	40
7	8' - 6"	4' - 3"	2' - 3"	11.6	40
8	9' - 6"	4' - 9"	2' - 7"	14.5	40
9	9' - 9"	4' - 10 1/2"	2' - 7"	15.3	48
10	10' - 0"	5' - 0"	2' - 7"	16.0	48

Leg Stubs & Anchors
RAL02
RAL03
RAL04
RAL05
RAL06
RAL07
RAL08
RAL09
RAL10

Standard foundations illustrated are for general information purposes only.
Actual details are provided with tower assembly drawings.



OPTIONAL ITEMS MUST BE ORDERED SEPARATELY

TOWER HEIGHT	RSL SECTION REFERENCE	TOP PLATE KIT	ACCESSORY SHELF	SECTOR MOUNT KIT	SHORT BASE KIT	ANCHOR BASE KIT	STEP BOLT KIT (ONE LEG)	SAFETY CABLE KIT
100'	1-10	RTP12	RASK12	RSM1	RSB10	RAL10	(10) RSLSTEP	TTRSL100
90	1-9	RTP12	RASK12	RSM1	RSB09	RAL09	(9) RSLSTEP	TTRSL100
	2-10	RTP12	RASK12	RSM2	RSB10	RAL10		
80	1-8	RTP12	RASK12	RSM1	RSB08	RAL08	(8) RSLSTEP	TTRSL100
	2-9	RTP12	RASK12	RSM2	RSB09	RAL09		
	3-10	RTP34	RASK34	RSM3	RSB10	RAL10		
70	1-7	RTP12	RASK12	RSM1	RSB07	RAL07	(7) RSLSTEP	TTRSL100
	2-8	RTP12	RASK12	RSM2	RSB08	RAL08		
	3-9	RTP34	RASK34	RSM3	RSB09	RAL09		
	4-10	RTP34	RASK34	RSM4	RSB10	RAL10		
60	1-6	RTP12	RASK12	RSM1	RSB06	RAL06	(6) RSLSTEP	TTRSL100
	4-9	RTP34	RASK34	RSM4	RSB09	RAL09		
	5-10	RTP56	RASK05	N/A	RSB10	RAL10		
50	1-5	RTP12	RASK12	RSM1	RSB05	RAL05	(5) RSLSTEP	TTRSL50
	5-9	RTP56	RASK05	N/A	RSB09	RAL09		
	6-10	RTP56	N/A	N/A	RSB10	RAL10		
40'	1-4	RTP12	RASK12	RSM1	RSB04	RAL04	(4) RSLSTEP	TTRSL50
	7-10	RTP07	N/A	N/A	RSB10	RAL10		
30	1-3	RTP12	RASK12	RSM1	RSB03	RAL03	(3) RSLSTEP	TTRSL50
	8-10	RTP08	N/A	N/A	RSB10	RAL10		
20	1-2	RTP12	RASK12	RSM1	RSB02	RAL02	(2) RSLSTEP	TTRSL50
	9-10	RTP09	N/A	N/A	RSB10	RAL10		

RSLAKITS R2

ROHN standard RSL tower kits are supplied with lock washers as nut locking devices. Pal nuts (P), ANCO nuts (A) and Tri-Loc nuts (T) are alternative nut locking devices that may be obtained by adding the indicated suffix to the standard RSL tower kit part number. *Nut locking devices are required in accordance with ANSI/TIA-222-G.*





SSV SELF-SUPPORTING TOWERS

SSV STANDARD

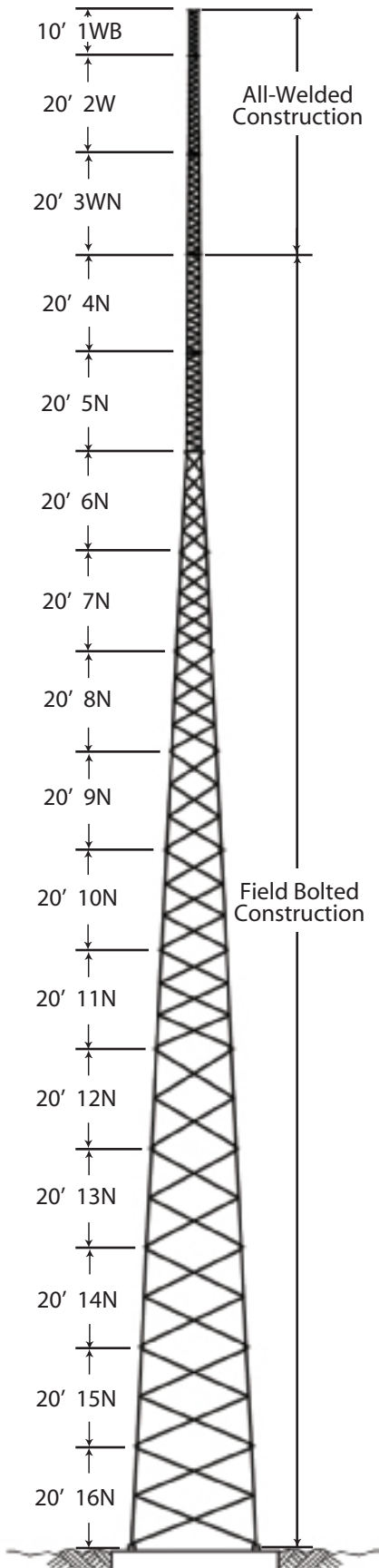

GENERAL USE

The ROHN SSV tower has been in service for over 50 years. The design utilizes standard parts arranged to create a unique structure. The legs are tubular with angle braces at the bottom and solid legs and braces in the top sections. This tower is used in a variety of applications, from PCS structures and broadband to security, sports lighting and more. The SSV has proven to be one of the industry's most efficient and preferred structures. All ROHN SSV towers are hot-dip galvanized, inside and out for corrosion protection.

*Do not use for construction.
See tower assembly drawings.*

Section Number	Nominal Spread Dimension	
	Upper	Lower
1WB	1' - 2"	1' - 2"
2W	1' - 2"	1' - 6"
3WN	1' - 6"	1' - 10"
4N	1' - 10"	2' - 2"
5N	2' - 2"	2' - 6"
6N	2' - 6"	4' - 6 1/4"
7N	4' - 6 1/4"	6' - 6 3/4"
8N	6' - 6 3/4"	8' - 6 3/4"
9N	8' - 6 3/4"	10' - 6 3/4"
10N	10' - 6 3/4"	12' - 7 1/4"
11N	12' - 7 1/4"	14' - 7 7/8"
12N	14' - 7 7/8"	16' - 8 3/8"
13N	16' - 8 3/8"	18' - 8 3/8"
14N	18' - 8 3/8"	20' - 9 3/8"
15N	20' - 9 3/8"	22' - 9 3/8"
16N	22' - 9 3/8"	24' - 9 3/8"

Per Rev G requirements, any structure greater than 10' requires a climber safety device. Please contact ROHN for ordering information.

SELF-SUPPORTING STANDARD TOWERS

REV G, 90 MPH 3-SEC, 3/4" ICE							
TOWER HEIGHT (FT.)	TOWER ASSEMBLY NUMBER	SECTIONS		EFFECTIVE PROJECTED AREA (SQ. FT.)			
		TOP	BASE	TOP		30' BELOW TOP	
				EXP B	EXP C	EXP B	EXP C
40	SS040R90	2W	3WN	18	13	31	19
50	SS050R90	1WB	3WN	7	5	12	7
60	SS060R90	2W	4N	15	10	25	16
70	SS070R90	1WB	4N	6	4	10	5
80	SS080R90	2W	5N	13	9	22	14
90	SS090R90	1WB	5N	5	3	8	5
100	SS100R90	2W	6N62	11	7	18	11
110	SS110R90	1WB	6N62	4	2	7	3
120	SS120R90	2W	7N165	10	6	17	10
130	SS130R90	1WB	7N165	4	2	7	3
140	SS140R90	2W	8N106	9	4	15	7
150	SS150R90	1WB	8N106	5	2	8	3
160	SS160R90	2W	9N325	8	-	14	-
170	SS170R90	1WB	9N325	5	-	8	-
180	SS180R90	2W	10N387	4	-	6	-

General Notes:

- Standard tower designs are in accordance with approved national standard ANSI/TIA-222-G, Structure Class II, Topographic Category 1, 3/4" design ice thickness, seismic coefficient $S_s \leq 1.0$.
- Tower designs assume allowable projected areas are symmetrically placed on the tower.
- Designs assume one 7/8 line to top and two 7/8 lines to 30 feet below top, one line on each face.
- All towers are provided with step bolts and a tapered top.
- Grounding kit must be ordered separately.
- Assembly drawings and standard foundation details are supplied with the tower.
- Custom designs for site-specific applications are available upon request.

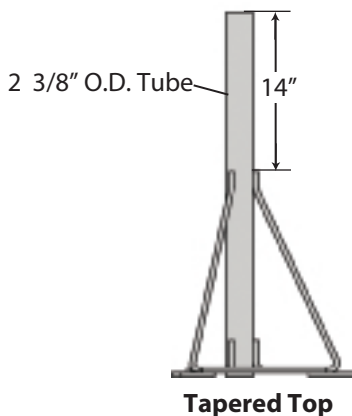

Assy. P/N	Tower Section No.
1TT	1W, 1WB, 2W
3TT	2WST, 2WB, 3WN
4TTN	3WNST, 3WNB, 4N
5TTN	4NST, 4NA, 4WB, 4NC, 5N
6TT	5NST, 5NA, 5NB, 5NC, 6C



SELF-SUPPORTING STANDARD TOWERS

REV G, 100 MPH 3-SEC, 3/4" ICE							
TOWER HEIGHT (FT.)	TOWER ASSEMBLY NUMBER	SECTIONS		EFFECTIVE PROJECTED AREA (SQ. FT.)			
		TOP	BASE	TOP		30' BELOW TOP	
				EXP B	EXP C	EXP B	EXP C
40	SS040R100	2W	3WN	14	10	24	15
50	SS050R100	1WB	3WN	5	3	8	5
60	SS060R100	2W	4N	11	7	18	12
70	SS070R100	1WB	4N	4	2	7	3
80	SS080R100	2W	5N	10	6	17	10
90	SS090R100	1WB	5N	3	2	5	2
100	SS100R100	2W	6N62	7	4	12	6
110	SS110R100	1WB	6N62	3	2	5	-
120	SS120R100	2W	7N165	6	2	10	3
130	SS130R100	1WB	7N165	2	-	3	-
140	SS140R100	2W	8N106	5	-	8	-
150	SS150R100	1WB	8N106	3	-	5	-
160	SS160R100	2W	9N325	4	-	6	-
170	SS170R100	1WB	9N325	2	-	2	-

General Notes:

1. Standard tower designs are in accordance with approved national standard ANSI/TIA-222-G, Structure Class II, Topographic Category 1, 3/4" design ice thickness, seismic coefficient $S_s \leq 1.0$.
2. Tower designs assume allowable projected areas are symmetrically placed on the tower.
3. Designs assume one 7/8 line to top and two 7/8 lines to 30 feet below top, one line on each face.
4. All towers are provided with step bolts and a tapered top.
5. Grounding kit must be ordered separately.
6. Assembly drawings and standard foundation details are supplied with the tower.
7. Custom designs for site-specific applications are available upon request.



SELF-SUPPORTING HEAVY DUTY SECTIONS

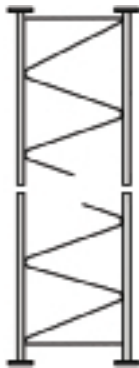

Bracing Detail for Sections 1W - 3WN
Solid Round Legs & Solid Round Braces

*Straight and Tapered Sections
available.*

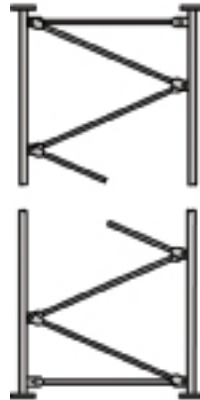

Bracing Detail for Sections 4N & 5N
Solid Round Legs & Solid Round Braces

*Straight and Tapered Sections
available.*

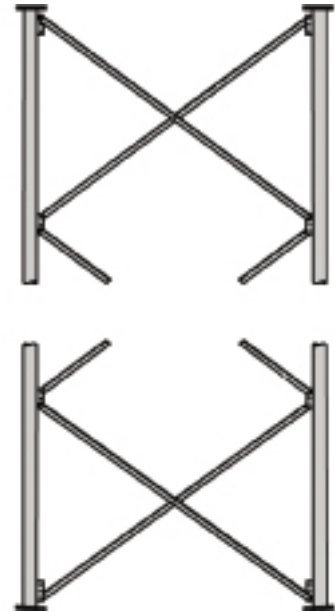

Bracing Detail for Straight Sections 6N - 11N
Tubular Legs & Angle Braces

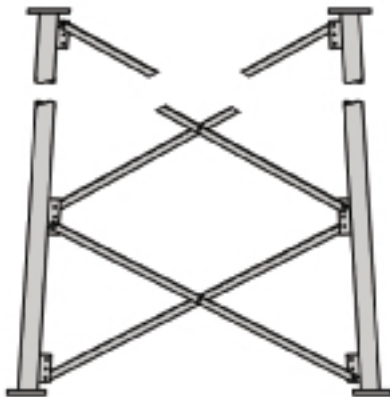

Bracing Detail for Tapered Sections 6N - 16NH
Tubular Legs & Angle Braces

TYPICAL SHORT BASE

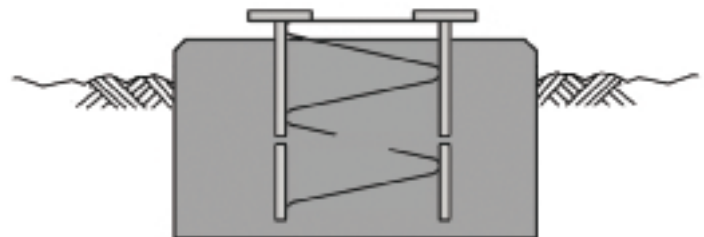

Part No: SB2, SB3, SB4 & SB5
*Installed when 2N - 5N sections are
used as tower base.*

Anchor bolt configurations are provided with larger towers.



SSV HD SELF-SUPPORTING TOWERS

SSV HEAVY DUTY

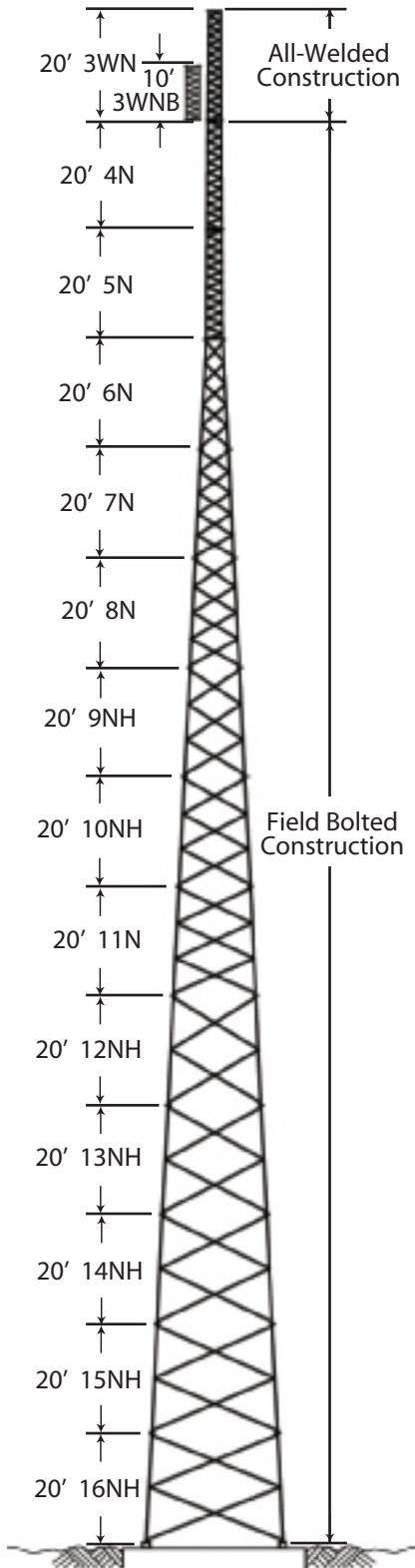

GENERAL USE

The ROHN SSV HD tower has the same features and utility as the SSV tower, but with Heavy Duty legs and braces. The heavy duty tower allows for the structure to support more loading and higher wind and ice loading. This tower serves the same applications as the SSV including: PCS, broadband, security, sports lighting and many others. The SSV HD also has standard "pre-engineered" towers created from standard sections. All ROHN SSV towers are hot-dip galvanized, inside and out for corrosion protection.

*Do not use for construction.
See tower assembly drawings.*

Section Number	Nominal Spread Dimension	
	Upper	Lower
3WN	1' - 6"	1' - 10"
3WNB	1' - 10"	1' - 10"
4N	1' - 10"	2' - 2"
5N	2' - 2"	2' - 6"
6N	2' - 6"	4' - 6 1/4"
7N	4' - 6 1/4"	6' - 6 3/4"
8N	6' - 6 3/4"	8' - 6 3/4"
9NH	8' - 6 3/4"	10' - 6 3/4"
10NH	10' - 6 3/4"	12' - 7 1/4"
11N	12' - 7 1/4"	14' - 7 7/8"
12NH	14' - 7 7/8"	16' - 8 3/8"
13NH	16' - 8 3/8"	18' - 8 3/8"
14NH	18' - 8 3/8"	20' - 9 3/8"
15NH	20' - 9 3/8"	22' - 9 3/8"
16NH	22' - 9 3/8"	24' - 9 3/8"

Per Rev G requirements, any structure greater than 10' requires a climber safety device. Please contact ROHN for ordering information.

SELF-SUPPORTING HEAVY DUTY STANDARD TOWERS

REV G, 90 MPH 3-SEC, 3/4" ICE							
TOWER HEIGHT (FT.)	TOWER ASSEMBLY NUMBER	SECTIONS		EFFECTIVE PROJECTED AREA (SQ. FT.)			
		TOP	BASE	TOP		30' BELOW TOP	
				EXP B	EXP C	EXP B	EXP C
40	SS040HD90	3WN	4N	41	29	60	40
50	SS050HD90	3WNB	5N	36	27	60	40
60	SS060HD90	3WN	5N	35	26	60	40
70	SS070HD90	3WNB	6N62	32	23	54	38
80	SS080HD90	3WN	6N62	22	15	37	25
90	SS090HD90	3WNB	7N165	27	18	46	30
100	SS100HD90	3WN	7N165	20	13	34	21
110	SS110HD90	3WNB	8N106	24	10	41	17
120	SS120HD90	3WN	8N106	18	11	31	18
130	SS130HD90	3WNB	9N82	21	9	36	15
140	SS140HD90	3WN	9N82	16	10	27	17
150	SS150HD90	3WNB	10N183	19	11	33	18
160	SS160HD90	3WN	10N183	15	8	25	14
170	SS170HD90	3WNB	11N332	18	9	31	15
180	SS180HD90	3WN	11N332	13	6	21	10

General Notes:

- Standard tower designs are in accordance with approved national standard ANSI/TIA-222-G, Structure Class II, Topographic Category 1, 3/4" design ice thickness, seismic coefficient $S_s \leq 1.0$.
- Tower designs assume allowable projected areas are symmetrically placed on the tower.
- Designs assume one 7/8 line to top and two 7/8 lines to 30 feet below top, one line on each face.
- All towers are provided with step bolts and a tapered top.
- Grounding kit must be ordered separately.
- Assembly drawings and standard foundation details are supplied with the tower.
- Custom designs for site-specific applications are available upon request.

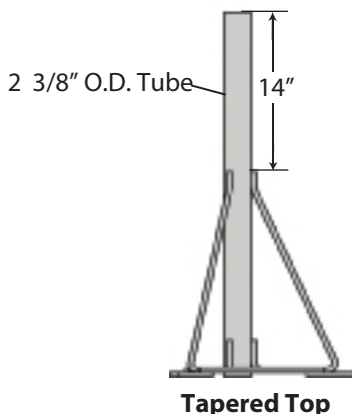

Assy. P/N	Tower Section No.
1TT	1W, 1WB, 2W
3TT	2WST, 2WB, 3WN
4TTN	3WNST, 3WNB, 4N
5TTN	4NST, 4NA, 4WB, 4NC, 5N
6TT	5NST, 5NA, 5NB, 5NC, 6C



SELF-SUPPORTING HEAVY DUTY STANDARD TOWERS

REV G, 100 MPH 3-SEC, 3/4" ICE							
TOWER HEIGHT (FT.)	TOWER ASSEMBLY NUMBER	SECTIONS		EFFECTIVE PROJECTED AREA (SQ. FT.)			
		TOP	BASE	TOP		30' BELOW TOP	
				EXP B	EXP C	EXP B	EXP C
40	SS040HD100	3WN	4N	32	23	50	38
50	SS050HD100	3WNB	5N	29	21	49	35
60	SS060HD100	3WN	5N	28	20	48	34
70	SS070HD100	3WNB	6N62	25	17	42	28
80	SS080HD100	3WN	6N62	17	11	28	18
90	SS090HD100	3WNB	7N165	19	11	32	18
100	SS100HD100	3WN	7N165	14	7	24	11
110	SS110HD100	3WNB	8N106	17	9	28	15
120	SS120HD100	3WN	8N106	12	5	20	9
130	SS130HD100	3WNB	9N82	14	8	24	13
140	SS140HD100	3WN	9N82	10	4	17	7
150	SS150HD100	3WNB	10N183	12	3	20	5
160	SS160HD100	3WN	10N183	9	-	15	-
170	SS170HD100	3WNB	11N332	9	-	15	-
180	SS180HD100	3WN	11N332	6	-	10	-

REV G, 110 MPH 3-SEC, 3/4" ICE							
TOWER HEIGHT (FT.)	TOWER ASSEMBLY NUMBER	SECTIONS		EFFECTIVE PROJECTED AREA (SQ. FT.)			
		TOP	BASE	TOP		30' BELOW TOP	
				EXP B	EXP C	EXP B	EXP C
40	SS040HD110	3WN	4N	26	18	40	30
50	SS050HD110	3WNB	5N	23	17	39	28
60	SS060HD110	3WN	5N	23	16	39	26
70	SS070HD110	3WNB	6N62	19	12	33	20
80	SS080HD110	3WN	6N62	12	7	20	11
90	SS090HD110	3WNB	7N165	13	7	22	10
100	SS100HD110	3WN	7N165	9	3	15	4
110	SS110HD110	3WNB	8N106	11	5	18	8
120	SS120HD110	3WN	8N106	7	2	11	3

General Notes:

1. Standard tower designs are in accordance with approved national standard ANSI/TIA-222-G, Structure Class II, Topographic Category 1, 3/4" design ice thickness, seismic coefficient $S_s \leq 1.0$.
2. Tower designs assume allowable projected areas are symmetrically placed on the tower.
3. Designs assume one 7/8 line to top and two 7/8 lines to 30 feet below top, one line on each face.
4. All towers are provided with step bolts and a tapered top.
5. Grounding kit must be ordered separately.
6. Assembly drawings and standard foundation details are supplied with the tower.
7. Custom designs for site-specific applications are available upon request.

SELF-SUPPORTING ANSI/TIA-222-G STANDARD FOUNDATIONS

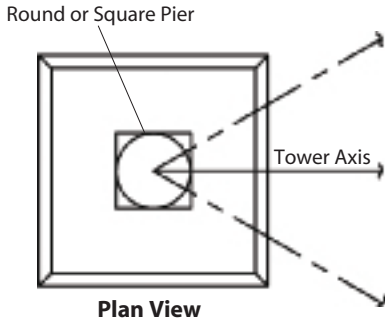

Plan View

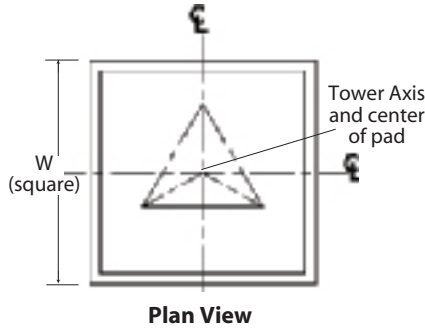

Plan View

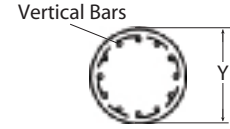

Section A-A

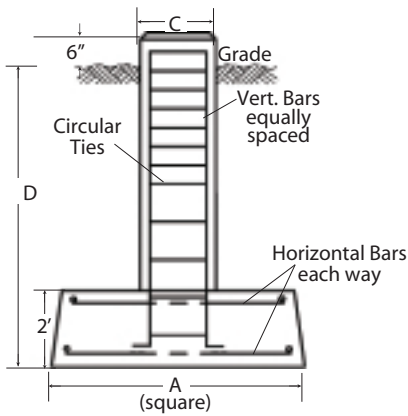

Pier & Pad
Elevation View

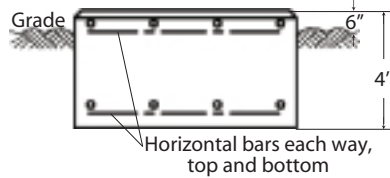

Mat
Elevation View

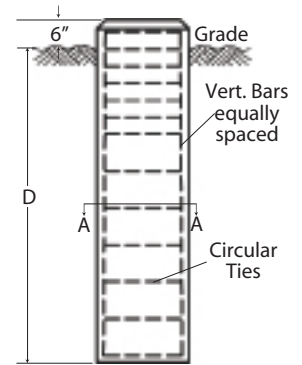

Drilled Pier
Elevation View

Tower Base Sect. No.	Pier & Pad					Mat		Drilled Pier		
	Dimensions			Req'd Conc. (cu. yds. 3 fdns)		W	Req'd Conc. (cu. yds.)	D	Y	Req'd Conc. (cu. yds.)
	D	A	C	Round	Square					
3WN	-	-	-	-	-	6' - 9"	6.8	-	-	-
4N	-	-	-	-	-	8' - 0"	9.5	-	-	-
5N	-	-	-	-	-	8' - 9"	11.3	-	-	-
6N62	-	-	-	-	-	10' - 3"	15.6	-	-	-
7N165	8' - 0"	4' - 6"	2' - 0"	6.3	6.9	11' - 6"	19.6	-	-	-
8N106	8' - 0"	5' - 0"	2' - 0"	7.3	7.9	14' - 3"	30.1	15' - 0"	2' - 6"	8.4
9N325/9N 82	8' - 0"	5' - 6"	2' - 0"	8.4	9.0	16' - 0"	37.9	18' - 0"	2' - 6"	10.2
10N387/10N183	8' - 6"	5' - 6"	2' - 0"	8.6	9.2	18' - 3"	49.3	20' - 0"	2' - 6"	11.1
11N332	9' - 0"	6' - 0"	2' - 6"	11.4	12.6	-	-	22' - 0"	2' - 6"	12.3

Standard foundations illustrated are for general information purposes only and are based on Rev G presumptive clay soil parameters. Foundation installation details are provided with tower assembly drawings.

SSMW SELF-SUPPORTING TOWERS

SSMW

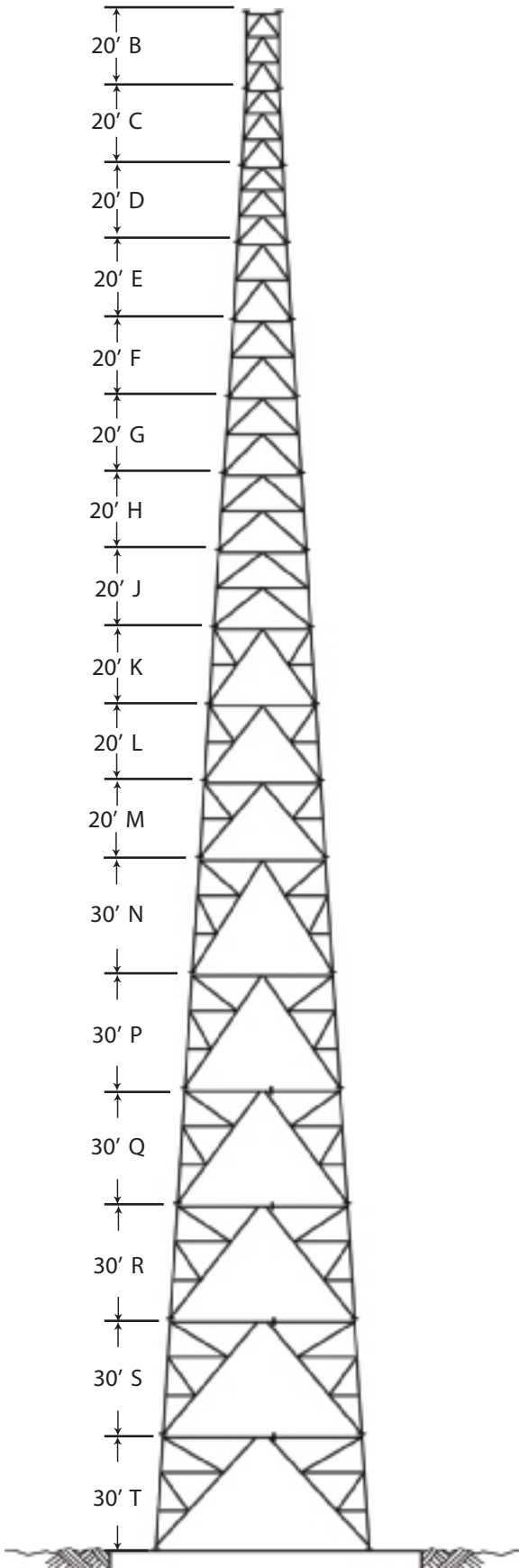

GENERAL USE

The ROHN SSMW tower is a unique design using a K-Brace system with horizontal plan bracing to allow free standing towers to reach heights to 900'. The SSMW is designed with pipe legs and pipe braces with flanges at each end for connection. The SSMW tower design can be used in conjunction with the SSV tower. All SSMW towers are hot-dip galvanized, inside and out for corrosion protection.

Section Number	Nominal Spread Dimension	
	Upper	Lower
B	8' - 6 1/2"	8' - 6 1/2"
C	8' - 6 1/2"	10' - 7"
D	10' - 7"	12' - 7 1/2"
E	12' - 7 1/2"	14' - 11 1/2"
F	14' - 11 1/2"	17' - 5 1/2"
G	17' - 5 1/2"	19' - 11 1/2"
H	19' - 11 1/2"	22' - 6 1/2"
J	22' - 6 1/2"	25' - 0 1/2"
K	25' - 0 1/2"	27' - 6 1/2"
L	27' - 6 1/2"	30' - 0 1/2"
M	30' - 0 1/2"	32' - 6 1/2"
N	32' - 6 1/2"	36' - 3 1/2"
P	36' - 3 1/2"	40' - 2 1/8"
Q	40' - 2 1/8"	43' - 11 1/8"
R	43' - 11 1/8"	47' - 8 1/8"
S	47' - 8 1/8"	51' - 5 1/8"
T	51' - 5 1/8"	55' - 2 1/8"

Per Rev G requirements, any structure greater than 10' requires a climber safety device. Please contact ROHN for ordering information.

SELF-SUPPORTING SSMW SECTIONS

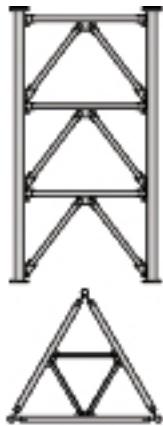

Typical section assembly detail for sections B, C & D.
Section E, F, G, H & J are identical except for the number of bays of bracing.

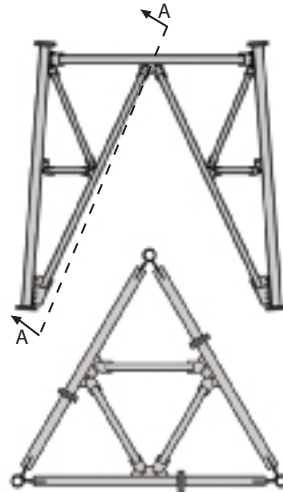

Typical section assembly detail for sections K, L & M.

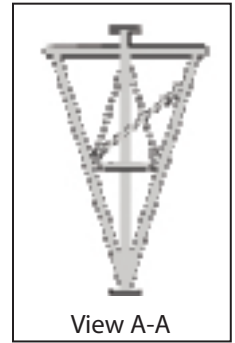

View A-A

SSMW SECTIONS

Sections are designed for many different sizes of braces and legs.

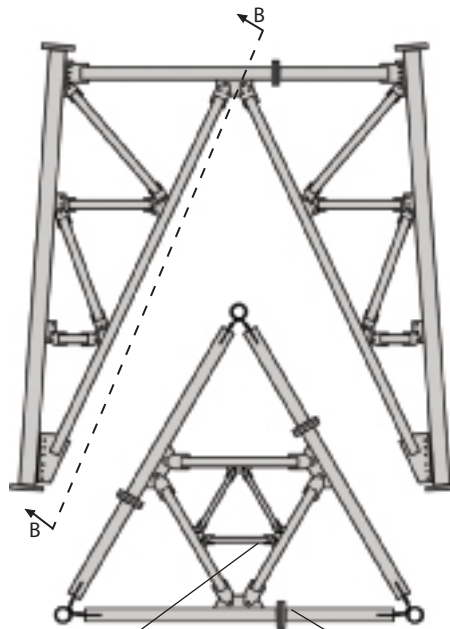

Typical section assembly detail for sections N, P, Q, R, S & T.

Secondary horizontal sub-bracing are used on sections Q, R, S & T.

Bracing splice connections are used on sections Q through T.

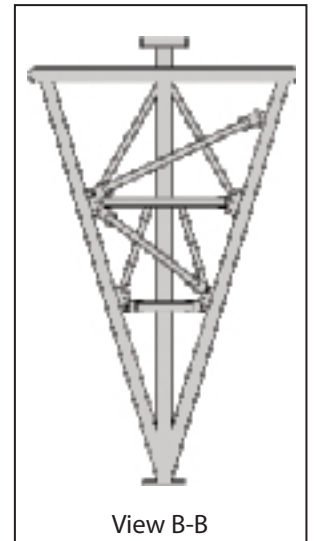

View B-B



SSVSR SELF-SUPPORTING TOWERS

SSVSR

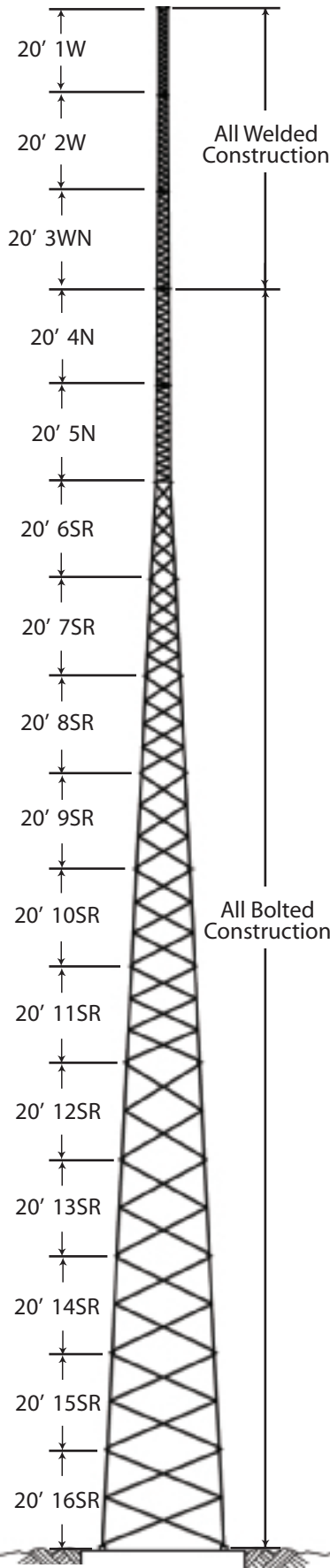

GENERAL USE

The ROHN SSVSR tower is similar in design to the ROHN SSV tower, but uses solid round legs instead of tubular legs. The SSVSR tower gives the versatility to switch to a solid leg, if desired. The standard side arms, dish mounts, ladders and waveguide supports that are used on the SSV tower can be used on the SSVSR tower. All SSVSR towers are hot-dip galvanized for corrosion protection.

Section Number	Nominal Spread Dimension	
	Upper	Lower
1W	1' - 2"	1' - 2"
2W	1' - 2"	1' - 6"
3WN	1' - 6"	1' - 10"
4N	1' - 10"	2' - 2"
5N	2' - 2"	2' - 6"
6SR	2' - 6"	4' - 6 1/4"
7SR	4' - 6 1/4"	6' - 6 3/4"
8SR	6' - 6 3/4"	8' - 6 3/4"
9SR	8' - 6 3/4"	10' - 6 3/4"
10SR	10' - 6 3/4"	12' - 7 1/4"
11SR	12' - 7 1/4"	14' - 7 7/8"
12SR	14' - 7 7/8"	16' - 8 3/8"
13SR	16' - 8 3/8"	18' - 8 3/8"
14SR	18' - 8 3/8"	20' - 9 3/8"
15SR	20' - 9 3/8"	22' - 9 3/8"
16SR	22' - 9 3/8"	24' - 9 3/8"

Per Rev G requirements, any structure greater than 10' requires a climber safety device. Please contact ROHN for ordering information.

SELF-SUPPORTING SOLID ROUND LEG SECTIONS

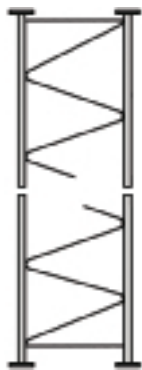

Bracing Detail for Sections 1W - 3WN
Solid Round Legs & Solid Round Braces

*Straight and Tapered Sections
available.*

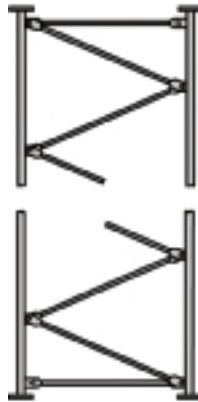

Bracing Detail for Sections 4N & 5N
Solid Round Legs & Solid Round Braces

*Straight and Tapered Sections
available.*

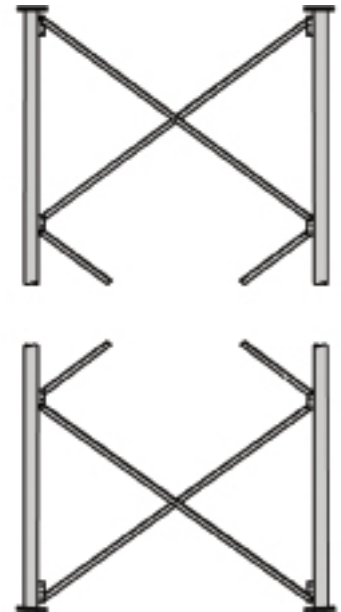

Bracing Detail for Straight Sections 6SR & 11SR
Solid Round Legs & Angle Braces



Bracing Detail for Tapered Sections 6SR - 16SR
Solid Round Legs & Angle Braces

TYPICAL SHORT BASE

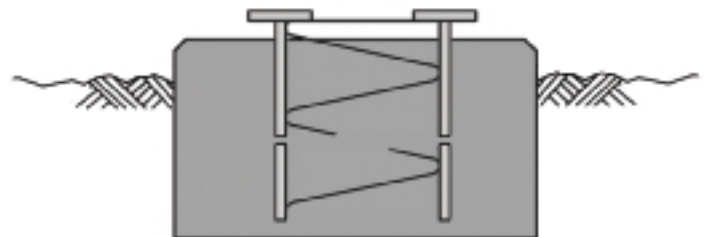

Part No: SB2, SB3, SB4 & SB5
*Installed when 2N - 5N sections are
used as tower base.*

Anchor bolt configurations are provided with larger towers.

SSVSR SECTIONS

Sections are designed for many different
sizes of braces and legs.

RS SELF-SUPPORTING TOWERS

RS

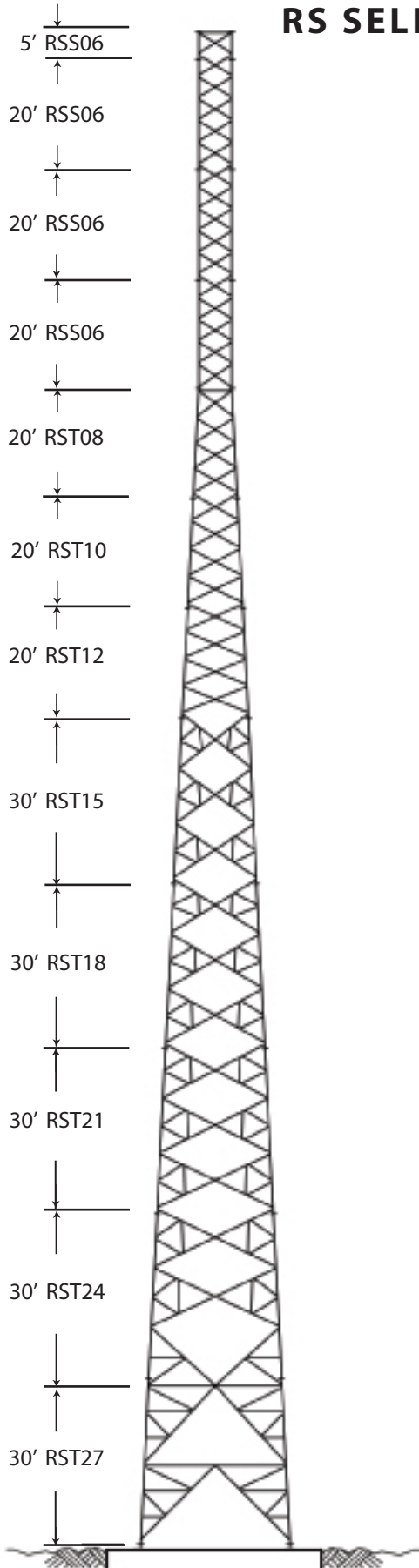

GENERAL USE

The ROHN RS tower is a unique solid round leg tower that uses angle braces in an X-Brace pattern. The RS tower is custom designed with standard components to shorten lead times. All RS towers are hot-dip galvanized for corrosion protection.

Section Number	Nominal Spread Dimension	
	Upper	Lower
RSS06	6'	6'
RST08	6'	8'
RST10	8'	10'
RST12	10'	12'
RST15	12'	15'
RST18	15'	18'
RST21	18'	21'
RST24	21'	24'
RST27	24'	27'

Per Rev G requirements, any structure greater than 10' requires a climber safety device. Please contact ROHN for ordering information.

SELF-SUPPORTING RS SECTIONS

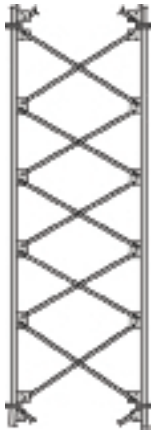

RSS 20' Straight Section
Solid Round Legs & Angle Braces

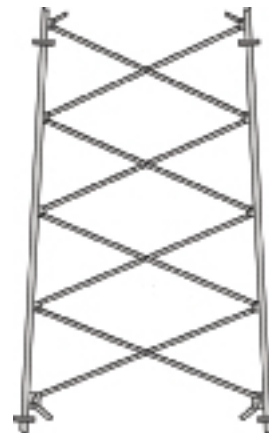

RST 20' Tapered Section
Solid Round Legs & Angle Braces

RS SECTIONS
Sections are designed for many different sizes of braces and legs.

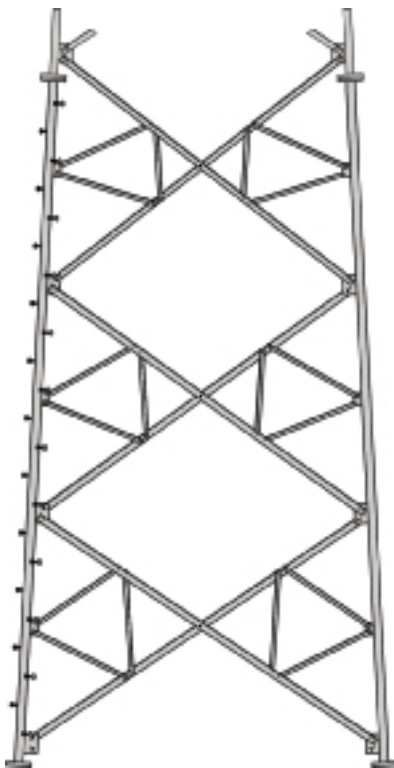

RST 30' Tapered Section
Solid Round Legs & Angle Braces

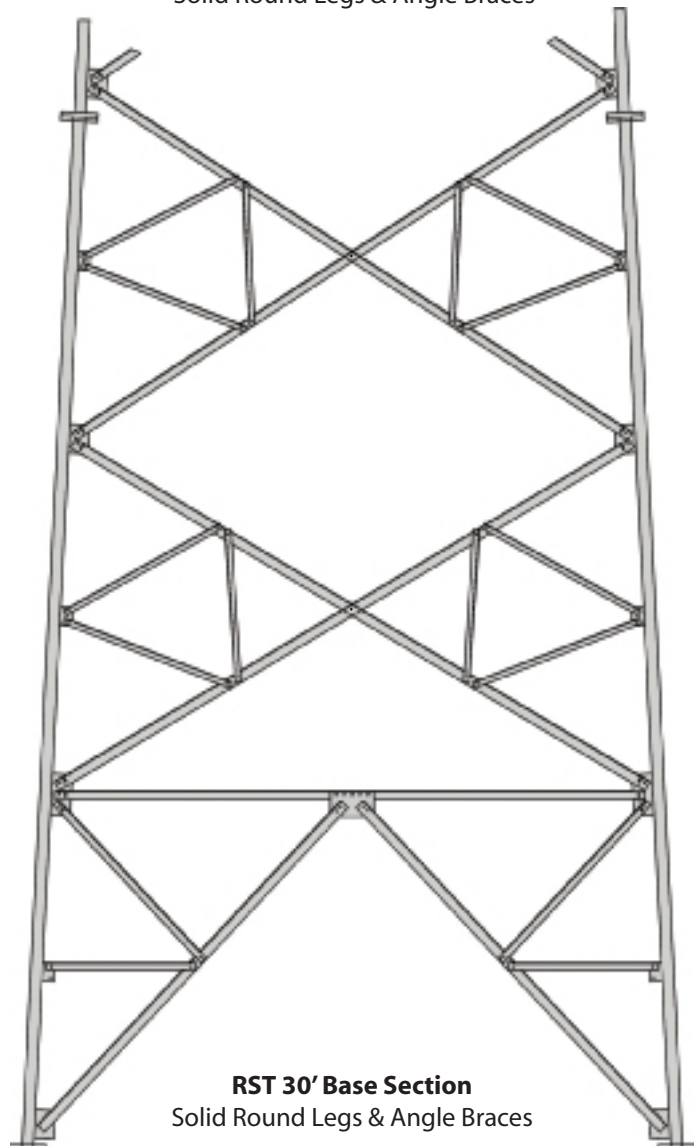

RST 30' Base Section
Solid Round Legs & Angle Braces

TOWER & SITE ACCESSORIES



3' AND 6' SIDE ARMS, STRAIGHT/TAPERED TOWER SECTIONS

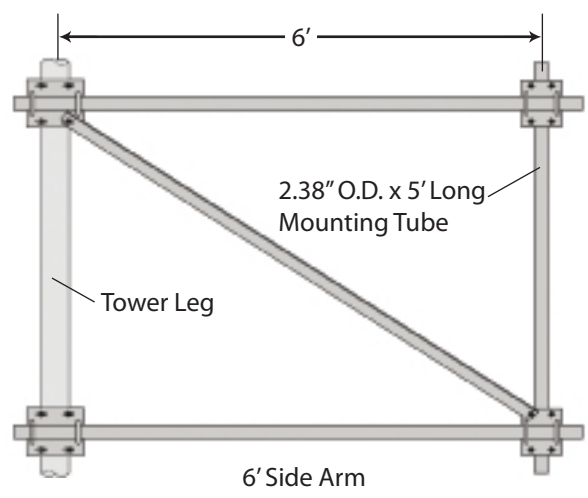
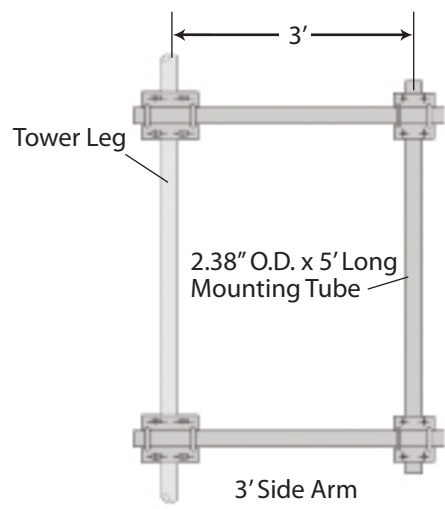

UNIVERSAL KITS

3' Side Arm	6' Side Arm	Tower Leg O.D.
SA324A	SA624A	2.38" - 4.50"
SA356A	SA656A	5.56" - 6.63"

LEG SPECIFIC KITS

3' Side Arm	6' Side Arm	Tower Leg O.D.
SA32PL	SA62PL	2.38"
SA325PL	SA625PL	2.88"
SA33PL	SA63PL	3.50"
SA335PL	SA635PL	4.00"
SA34PL	SA64PL	4.50"
SA35PL	SA65PL	5.56"
SA36PL	SA66PL	6.63"
SA38PL	SA68PL	8.63"
SA310PL	SA610PL	10.75"
SA312PL	SA612PL	12.75"

Notes:

1. Standard tiebacks to the supporting structure are available for towers with 8.5 ft. or less face width.
2. To order tiebacks, include (1TB) for one or (2TB) for two after side arm assembly part number.
3. Custom side arms and tiebacks are available upon request.
4. Check for leg size to determine assembly number required.

All side arms are hot-dip galvanized and include all hardware to attach mount to tower.

LEG DISH MOUNTS

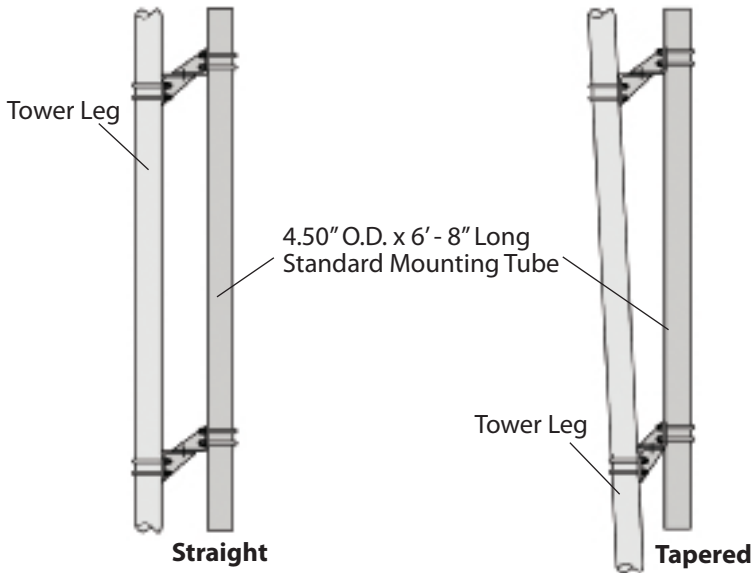

Straight Leg	
Part No.	Description
S24HUM	Fits leg sizes 2.38" O.D. - 4.50" O.D.
S56HUM	Fits leg sizes 5.50" O.D. - 6.63" O.D.

Tapered Leg	
Part No.	Description
T24HUM	Fits leg sizes 2.38" O.D. - 4.50" O.D.
T56HUM	Fits leg sizes 5.50" O.D. - 6.63" O.D.

LEG TIE-BACK PLATE KIT

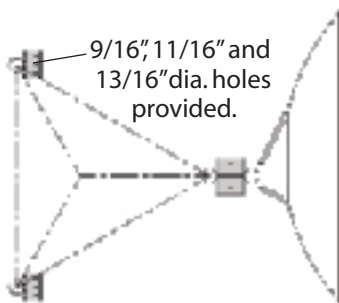

Part No.	Leg O.D.
VY1949A	2.38"
VY1950A	2.88"
VY1951A	3.50"
VY1952A	4.00"
VY1953A	4.50"
VY1954A	5.50"
VY1955A	6.63"

Kits include (1) clip with u-bolts. Some dishes require (2) tie-backs.

TIE-BACK ASSEMBLIES

[Follow steps 1-4 to order]

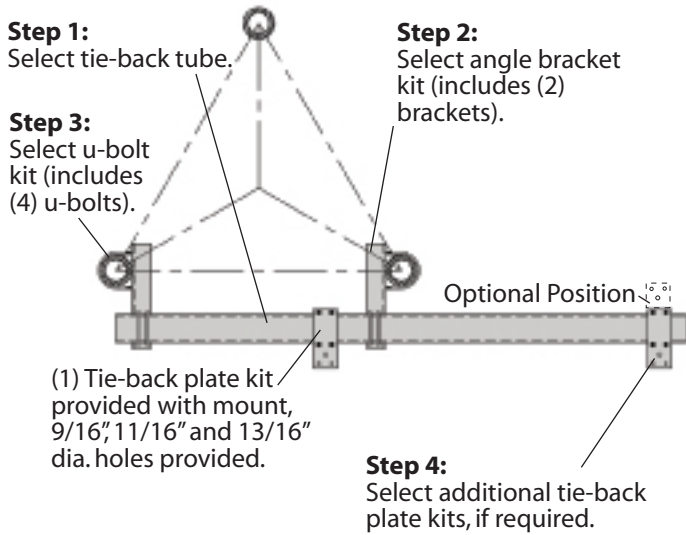

All mounts and tie-back assemblies are hot-dip galvanized and include all hardware to attach mount to tower.

Step 1. Select Tie-Back Tube Size & Length

TS 6" x 6" x 3/16"	
Part No.	Length
TMT6LL05	5'
TMT6LL06	6'
TMT6LL08	8'
TMT6LL10	10'
TMT6LL12	12'

TS 6" x 6" x 1/4"	
Part No.	Length
TMT6L05	5'
TMT6L06	6'
TMT6L08	8'
TMT6L10	10'
TMT6L12	12'

TS 6" x 6" x 3/8"	
Part No.	Length
TMT6H05	5'
TMT6H06	6'
TMT6H08	8'
TMT6H10	10'
TMT6H12	12'

Step 2. Select Angle Bracket Kit Based on leg O.D.

4" Tube	
Part No.	Leg O.D.
VY2911A	1.90" - 5.56"
VY2912A	6.63" - 8.63"

6" Tube	
Part No.	Leg O.D.
VY4457A	1.90" - 5.56"
VY4458A	6.63" - 8.63"
VY4459A	10.75" - 12.75"

Step 3. Select U-Bolt Kit Based on leg O.D.

Part No.	Leg O.D.
JR83AW4	1.90" - 2.38"
JR84AW4	2.88"
JR88AW4	3.50"
JR89AW4	4.00"
JR85AW4	4.50"
JR86AW4	5.56"
JR87AW4	6.63"
JR90SAW4	8.63"
JR110AW4	10.75"
JR120AW4	12.75"

Step 4. Select Additional Tie-Back Plate Kits (if required).

Part No.	Tube Size
AP34T4	4"
AP6T2	6"

FACE DISH MOUNTS

[FOLLOW STEPS 1-3 TO ORDER]

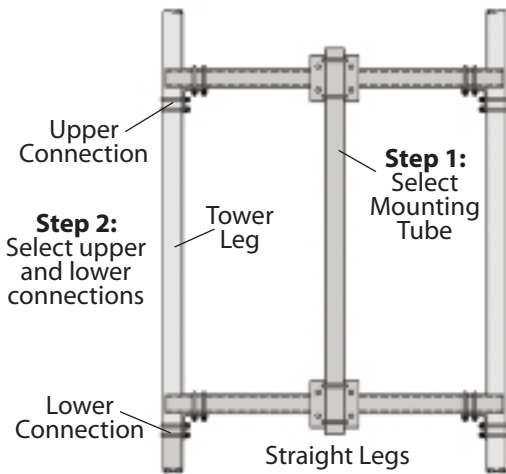

ORDERING INFORMATION:

Step 1. Select Mounting Tube Length (4.50" O.D. x 0.237" wall)

Straight Leg	
Part No.	Tube Description
DMF4T050S	4.50" O.D. x 5'
DMF4T068S	4.50" O.D. x 6.67'
DMF4T100S	4.50" O.D. x 10'

Tapered Leg	
Part No.	Tube Description
DMF4T050T	4.50" O.D. x 5'
DMF4T068T	4.50" O.D. x 6.67'
DMF4T100T	4.50" O.D. x 10'

Step 2. Select Upper and Lower Connections

Because leg O.D. may be different at upper and lower connections, select one part number for upper and one part number for lower.

Straight or Tapered Legs	
Part No.	Leg O.D.
JR83AW4	1.90" - 2.38"
JR84AW4	2.88"
JR88AW4	3.50"
JR89AW4	4.00"
JR85AW4	4.50"
JR86AW4	5.56"

(2) Brackets are included with each kit.

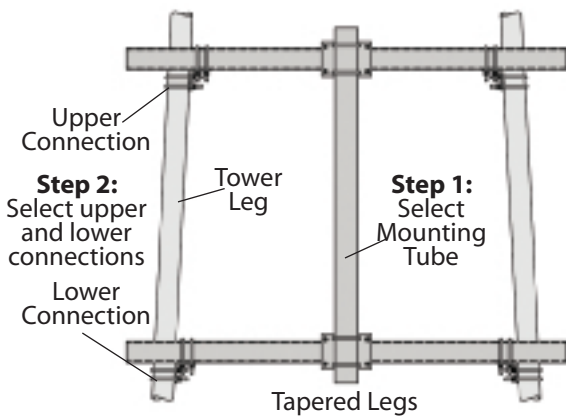

Step 3. Select Square Tube Supports

Based on required strength and length. Select (1) part number for upper support and (1) part number for lower support.

4" x 4" x 11GA	
Part No.	Length
TMT4L05	5'
TMT4L06	6'
TMT4L08	8'
TMT4L10	10'

4" x 4" x .25"	
Part No.	Length
TMT4H05	5'
TMT4H06	6'
TMT4H08	8'
TMT4H10	10'

4" x 4" x .375"	
Part No.	Length
TMT4XH05	5'
TMT4XH06	6'
TMT4XH08	8'
TMT4XH10	10'

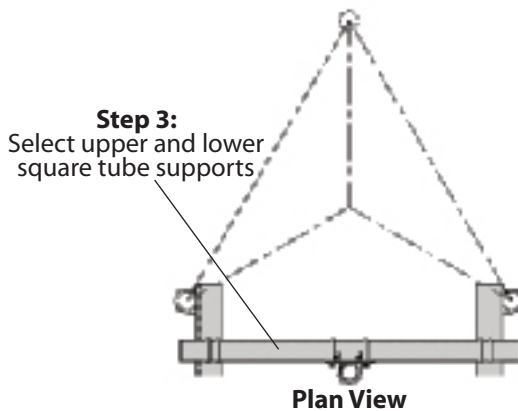

FACE MOUNT KITS

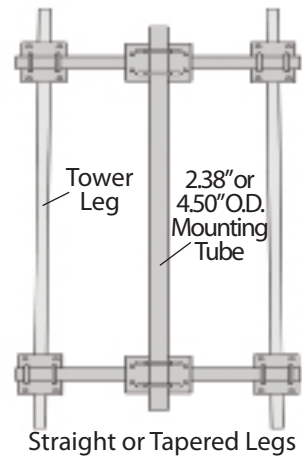

LIGHTWEIGHT FACE MOUNT KITS
 FITS MIN. FACE WIDTH 18" TO MAX. FACE WIDTH 30",
 LEG SIZES 1" TO 1 3/4" O.D.

Part No.	Mounting Tube
FM35NU2	2.38" O.D. x 0.154" wall x 5' Long
FM35NU4	4.50" O.D. x 0.237" wall x 5' Long

Face dish mounts are hot-dip galvanized and include all required hardware to attach mount to tower.

SECTOR MOUNT

[FOLLOW STEPS 1-3 TO ORDER]

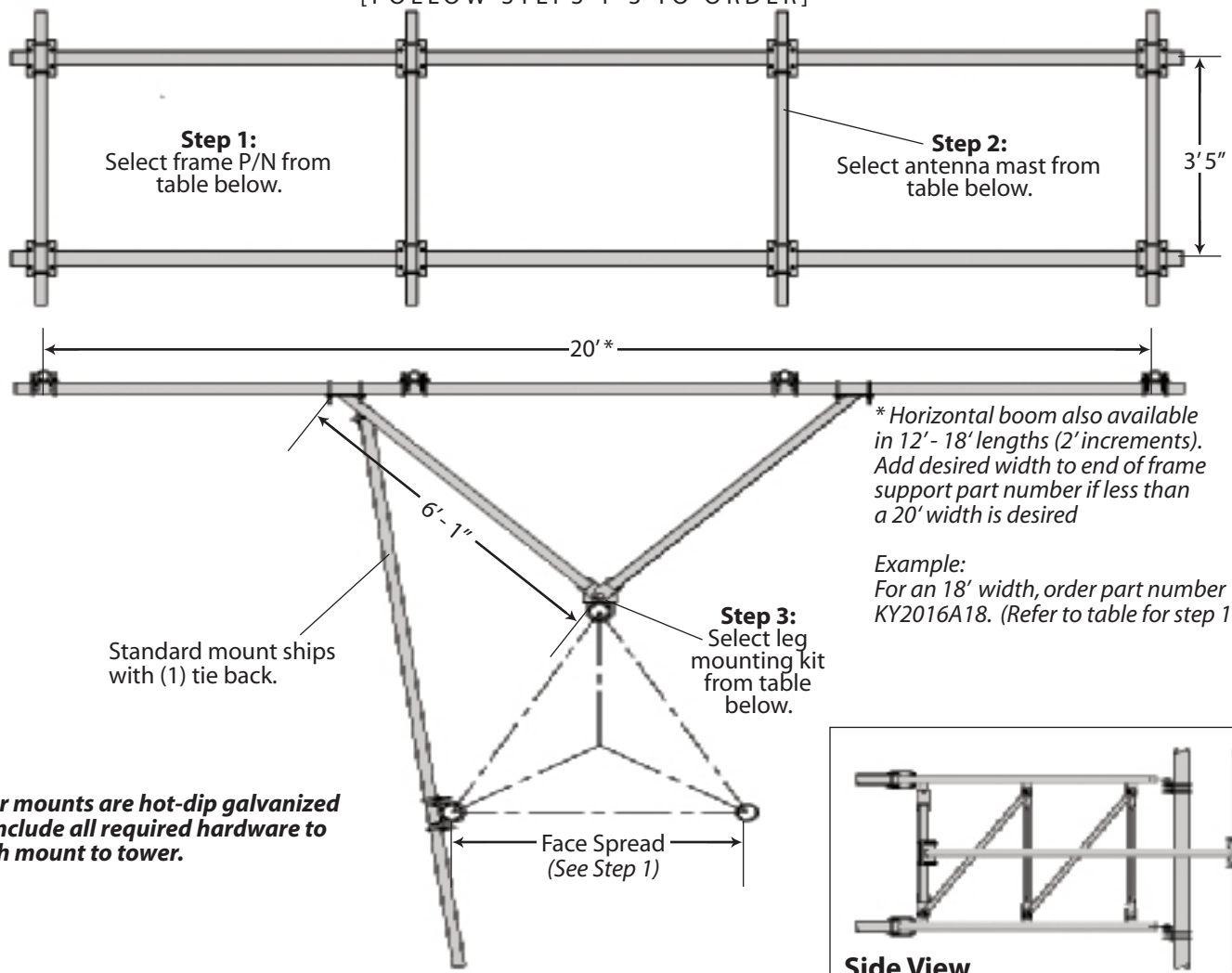

Sector mounts are hot-dip galvanized and include all required hardware to attach mount to tower.

SECTOR MOUNT ORDERING INFORMATION

(Qty. is for (1) sector only)

Step 1. Select frame P/N based on tower face spread.

Frame Support Assembly Straight Leg	
Part No.	Face Spread
KY2016A	8' Max.
KY1993A	8' Min. - 14' Max.

Frame Support Assembly Tapered Leg	
Part No.	Face Spread
KY2006A	8' Max.
KY2015A	8' Min. - 14' Max.

Step 2. Select antenna mast kits (2 min.) (1) Kit per mast tube

Antenna Mast Kit	
Part No.	Mast
VY4935A	2.38" O.D. (0.154" wall) x 5' Long
VY4935A8	2.38" O.D. (0.218" wall) x 8' Long

Step 3. Select leg mounting kit.

Leg Mounting Kit Straight Leg	
Part No.	Leg O.D.
KY1994A	2.38" O.D.
KY1995A	2.88" O.D.
KY1996A	3.50" O.D.
KY1997A	4.00" O.D.
KY1998A	4.50" O.D.
KY1999A	5.56" O.D.
KY2000A	6.63" O.D.
KY2001A	8.63" O.D.

Leg Mounting Kit Tapered Leg	
Part No.	Leg O.D.
KY2007A	2.38" O.D.
KY2008A	2.88" O.D.
KY2009A	3.50" O.D.
KY2010A	4.00" O.D.
KY2011A	4.50" O.D.
KY2012A	5.56" O.D.
KY2013A	6.63" O.D.
KY2014A	8.63" O.D.

ROTOR PLATE ASSEMBLIES FOR ROHN STANDARD SELF-SUPPORTING TOWERS

Rotor plate accessories are hot-dip galvanized and include all required hardware to attach assemblies to tower.

1W / 2W

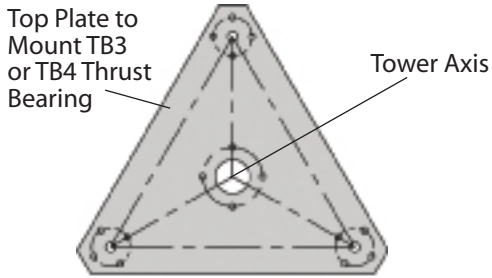

3WN

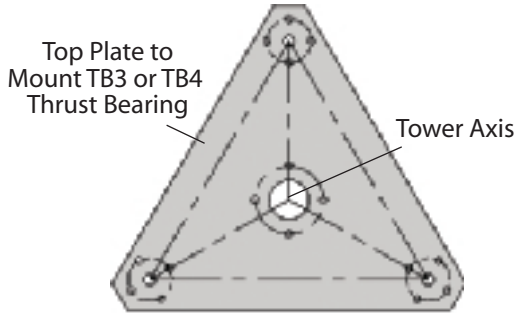

3WNST / 3WNB

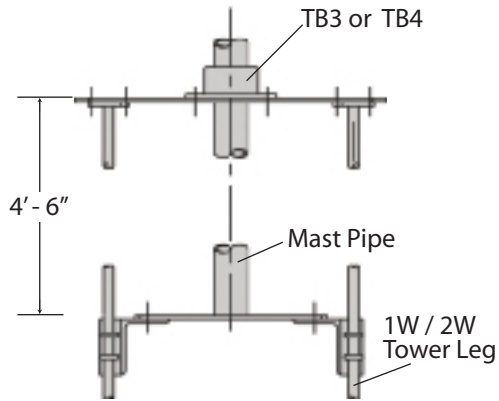
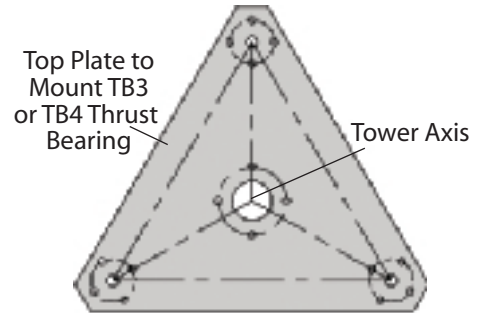

P/N: VU479A

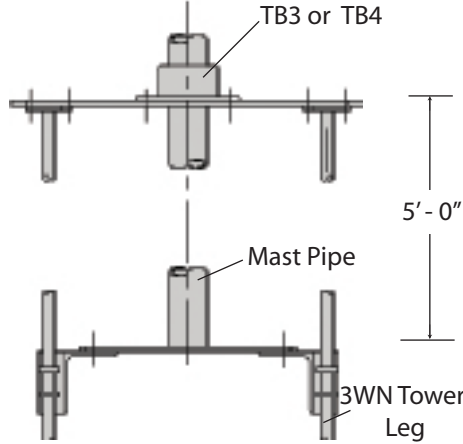

P/N: VU474A

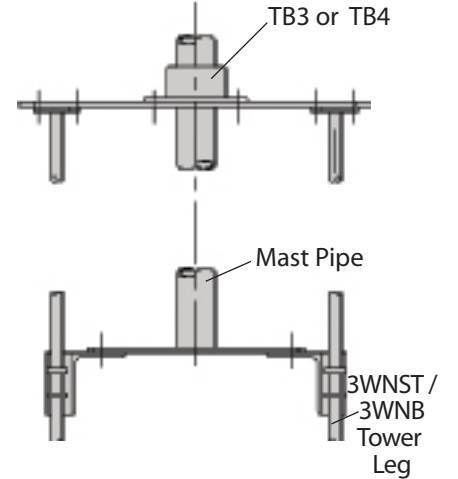

P/N: VU140

NOTES:

1. All plates are 3/8" thick
2. Rotor top plates are pre-drilled to fit a variety of rotors.
3. Rotor plate assembly includes top plate and rotor plate.
4. Mast pipe, rotor and thrust bearing must be ordered separately.

SAFETY & CLIMBING G-SERIES TOWERS | POLES

SAFETY CABLE - TOWERS

Description	Part Number
50' - 25G tower	TT05025
100' - 25G tower	TT10025
150' - 25G tower	TT15025
200' - 25G tower	TT20025

Description	Part Number
50' - 45G/55G tower	TT0504555
100' - 45G/55G tower	TT1004555
150' - 45G/55G tower	TT1504555
200' - 45G/55G tower	TT2004555
250' - 45G/55G tower	TT2504555
300' - 45G/55G tower	TT3004555
350' - 45G/55G tower	TT3504555

Description	Part Number
50' - 65G tower	TT05065
100' - 65G tower	TT10065
150' - 65G tower	TT15065
200' - 65G tower	TT20065
250' - 65G tower	TT25065
300' - 65G tower	TT30065
350' - 65G tower	TT35065
400' - 65G tower	TT40065
450' - 65G tower	TT45065
500' - 65G tower	TT50065

SAFETY CABLE - POLES

Description	Part No.	Cable (ft.)	# Guides
25' - Pole	TT025TSP	35	1
50' - Pole	TT050TSP	60	2
100' - Pole	TT100TSP	110	4
150' - Pole	TT150TSP	160	6
200' - Pole	TT200TSP	210	8
250' - Pole	TT250TSP	260	10
Step Anchor Bracket	TTSBAB	-	-
Additional 4" Stud Cable Guide	TT115317-4	-	-

HARNESS & SLIDER

Description	Part Number
4-D Ring Climbing Harness	TTFBH-4D
Professional Harness	TTFBH-C/P
Safety Cable Slider	TT-WG-500-W/SMC



Climbing Harness



Safety Cable Slider with Carabiner

SAFETY CABLE SYSTEM FOR CLIMBING LADDERS - TOWERS

Description	Part Number
50' Climbing Ladder	TT050LAD
100' Climbing Ladder	TT100LAD
150' Climbing Ladder	TT150LAD
200' Climbing Ladder	TT200LAD
250' Climbing Ladder	TT250LAD
300' Climbing Ladder	TT300LAD

CLIMBING LADDERS

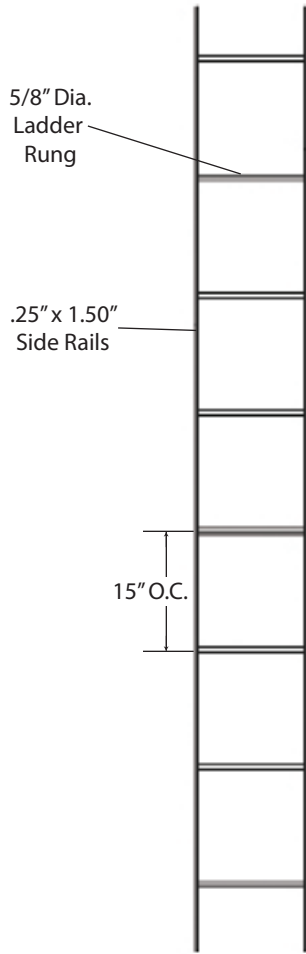

STANDARD LADDER
NL10 - 10' ladder
NL20 - 20' ladder

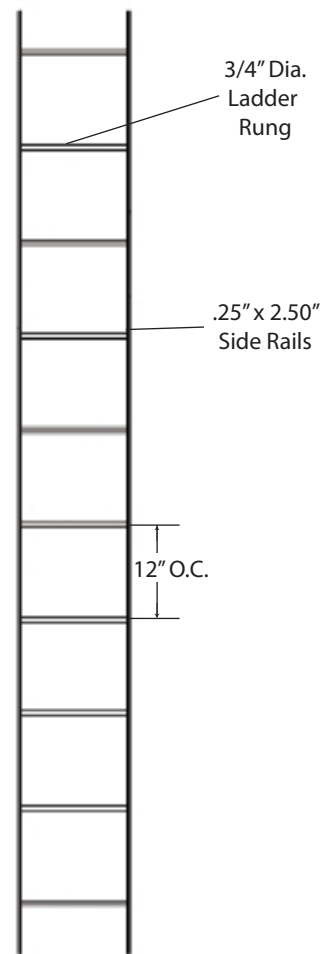

HEAVY DUTY LADDER
HL161A - 10' ladder
HL162A - 20' ladder

Part number for ladder section only. Mounting kit must be ordered separately.

CONFIGURATIONS

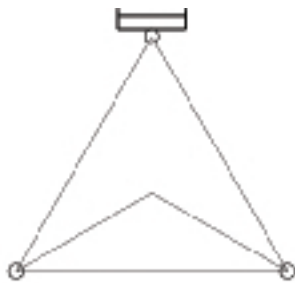

Leg Mounted

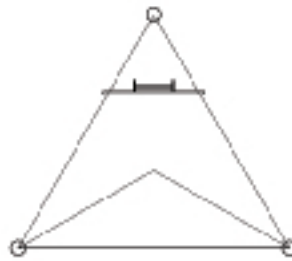

Inside Corner Mounted

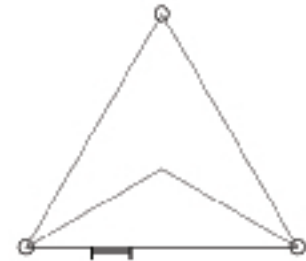

Face Mounted

Notes:

1. Ladders are available for most ROHN standard tower sections.
2. All ROHN climbing devices are intended for use by professional (competent climbers) only.
3. Specify ladder type and configuration when ordering.
4. Custom configurations and mounting options available.
5. A safety climb system is required for all structures greater than 10' in height.

WAVEGUIDE LADDER FACE MOUNTED 9-HOLE

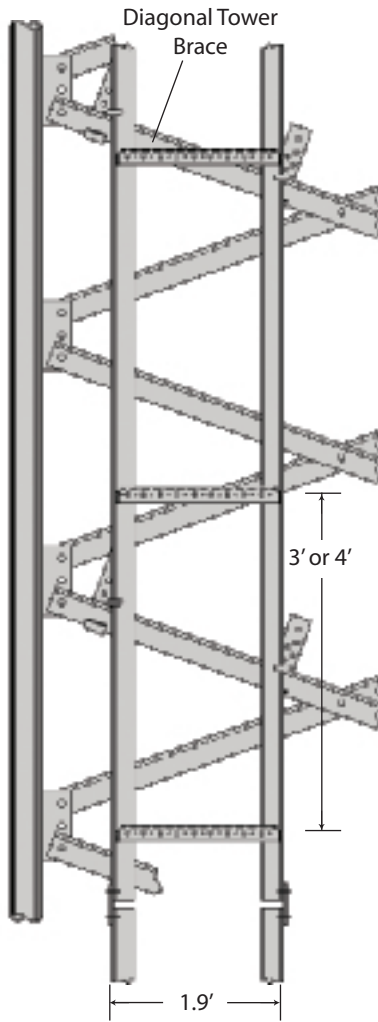

Waveguide Ladder Elevation

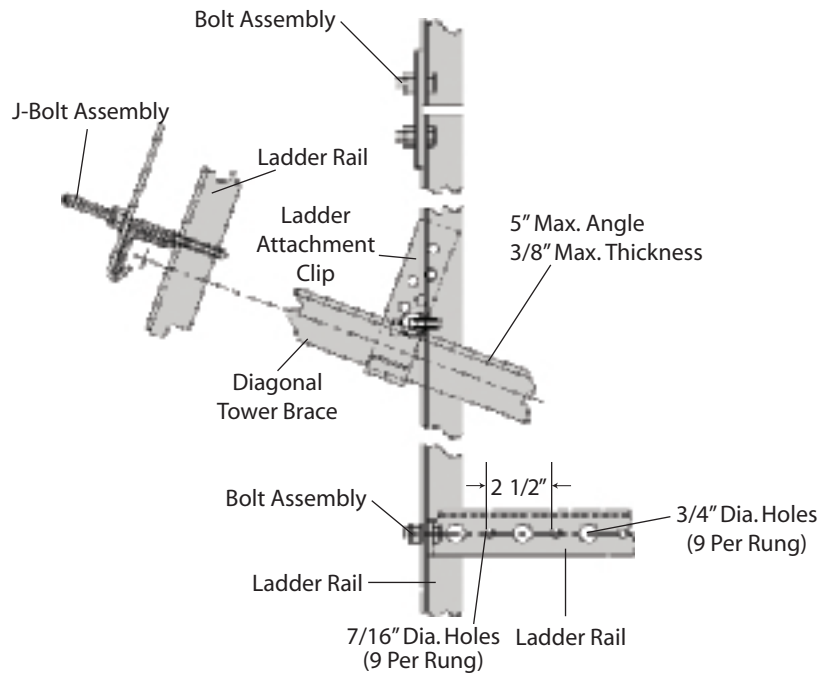

ORDERING INFORMATION

WL20F93KD
20' Long Waveguide Ladder (3' rung spacing)

WL20F94KD
20' Long Waveguide Ladder (4' rung spacing)

WL10F93KD
10' Long Waveguide Ladder (3' rung spacing)

WL10F94KD
10' Long Waveguide Ladder (4' rung spacing)

Notes:

1. Waveguide ladder may be moved horizontally for the proper alignment.
2. Waveguide ladder may be mounted inside or outside of tower as required.

WAVEGUIDE LADDER FACE MOUNTED 12-HOLE

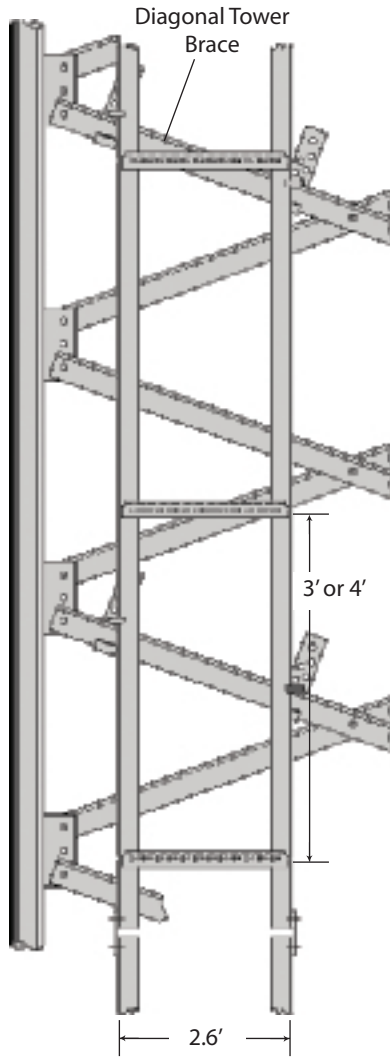

Waveguide Ladder Elevation

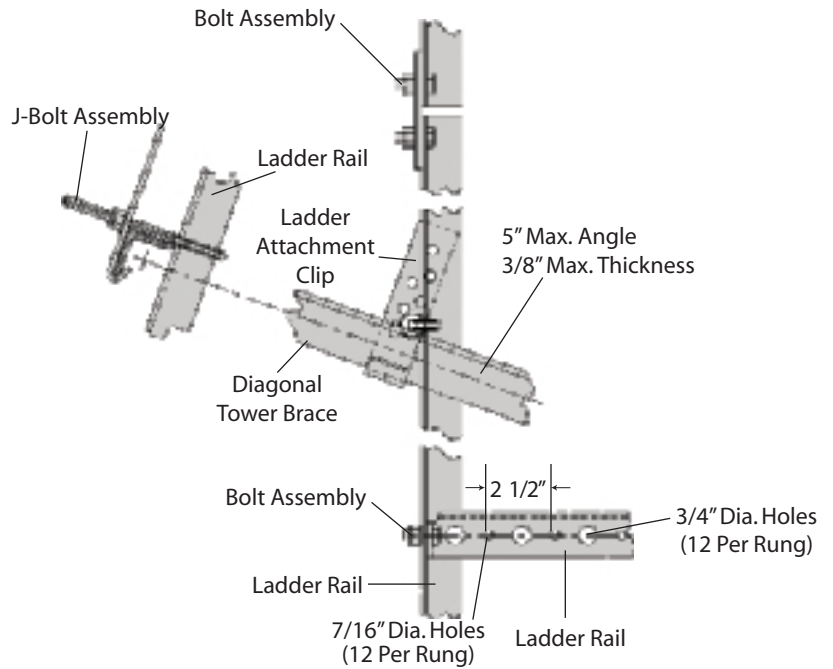

ORDERING INFORMATION

WL20F123KD

20' Long Waveguide Ladder (3' rung spacing)

WL20F124KD

20' Long Waveguide Ladder (4' rung spacing)

WL10F123KD

10' Long Waveguide Ladder (3' rung spacing)

WL10F124KD

10' Long Waveguide Ladder (4' rung spacing)

Notes:

1. Waveguide ladder may be moved horizontally for the proper alignment.
2. Waveguide ladder may be mounted inside or outside of tower as required.

WAVEGUIDE LADDER FACE MOUNTED 15-HOLE

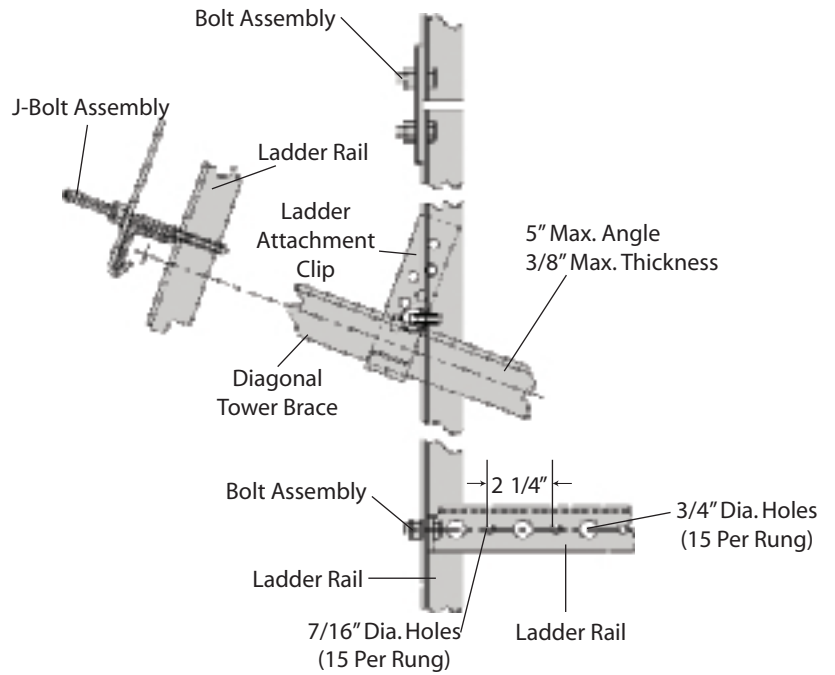
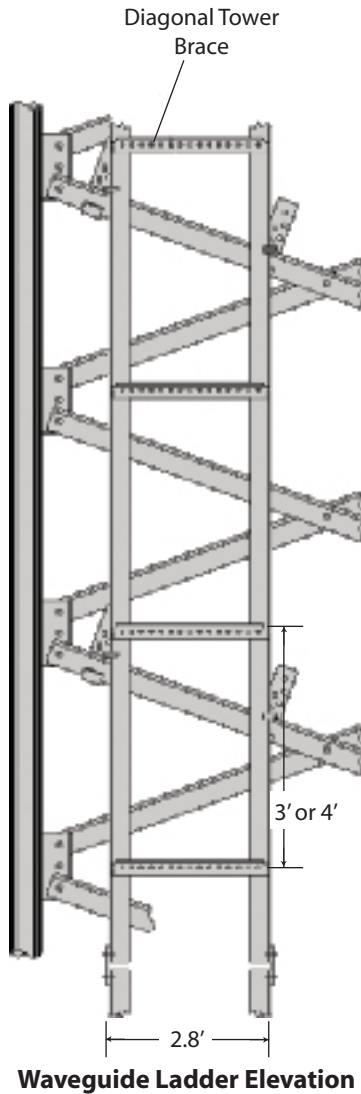

ORDERING INFORMATION

WL20F153KD
20' Long Waveguide Ladder (3' rung spacing)

WL20F154KD
20' Long Waveguide Ladder (4' rung spacing)

WL10F153KD
10' Long Waveguide Ladder (3' rung spacing)

WL10F154KD
10' Long Waveguide Ladder (4' rung spacing)

Notes:

1. Waveguide ladder may be moved horizontally for the proper alignment.
2. Waveguide ladder may be mounted inside or outside of tower as required.

WAVEGUIDE BRACKETS 3-HOLE

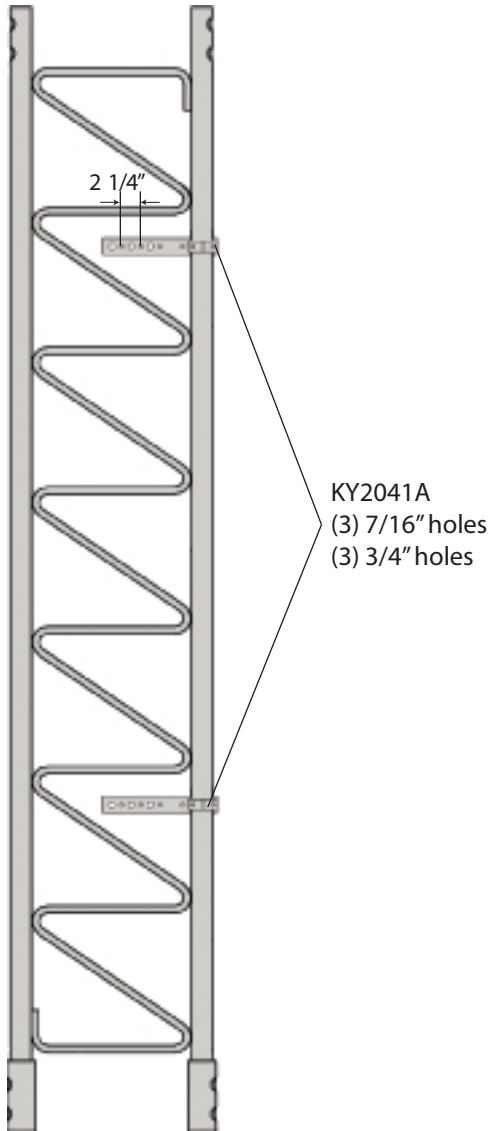

ORDERING INFORMATION

KY2041A

Notes:

- 1. Kit includes (1) bracket with required mounting hardware.
- 2. Assembly used for mounting to 3/4" - 2 1/4" O.D. legs.
- 3. (5) KY2041A required per 20' of tower for 4' O.C. spacing.

Waveguide Bracket Elevation

WAVEGUIDE BRACKETS 8-HOLE (80 SERIES)

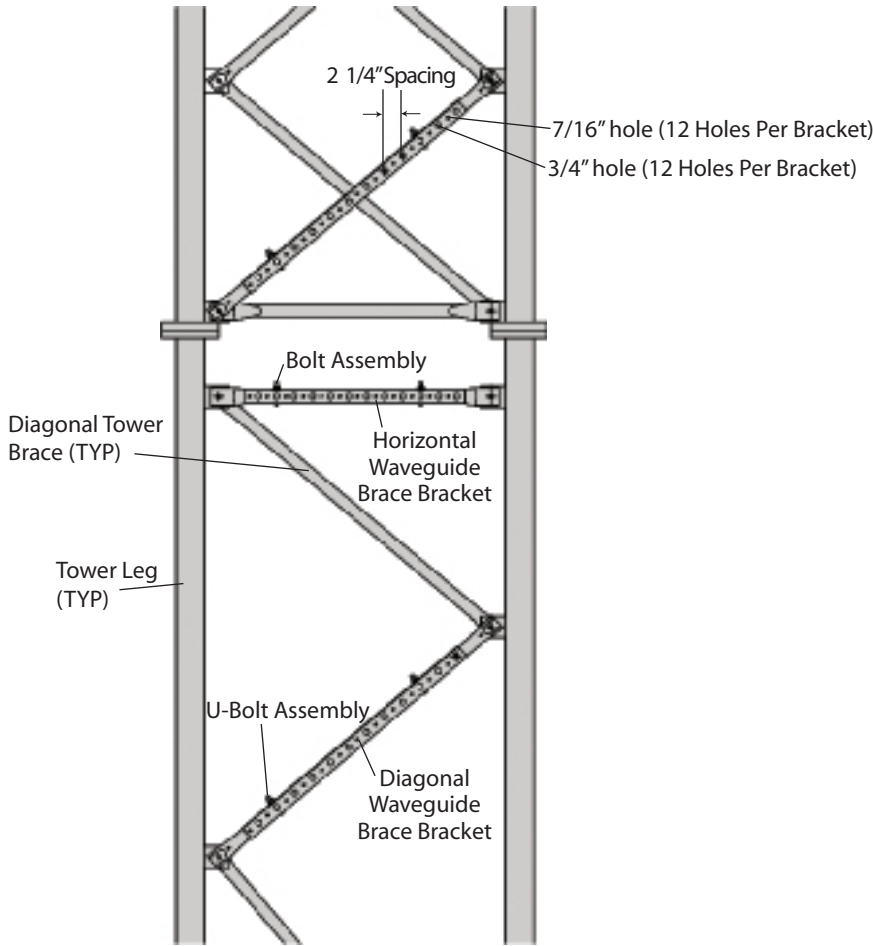

Tubular Bracing
1 1/2" Diameter

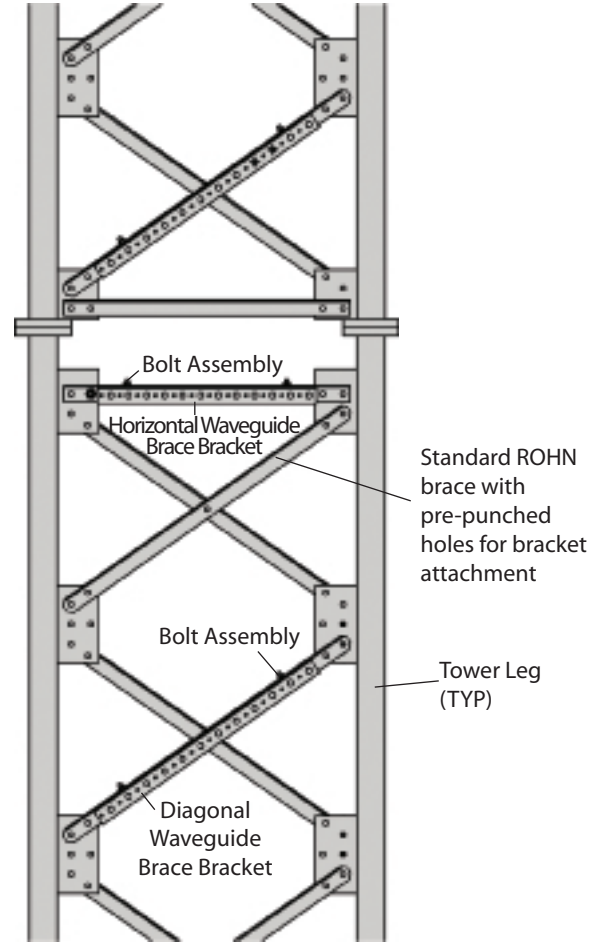

Angle Bracing
1 3/4" x 3/16"
2" x 1/4"

ORDERING INFORMATION

WAF801211
(Horizontals)
Order 1 per 15' or 20' section

WAF801212
(Diagonals)
Order 3 per 15' section
Order 4 per 20' section

ORDERING INFORMATION

WAF801213
(Horizontals)
Order 1 per 15' or 20' section

WAF801214
(2" Diagonals)
Order 3 per 15' section
Order 4 per 20' section

WAF801215
(1 3/4" Diagonals)
Order 3 per 15' section
Order 4 per 20' section

NOTE: These assemblies may be mounted on the inside or outside face of the tower.

**WAVEGUIDE BRACKETS
15-HOLE (90 SERIES)**

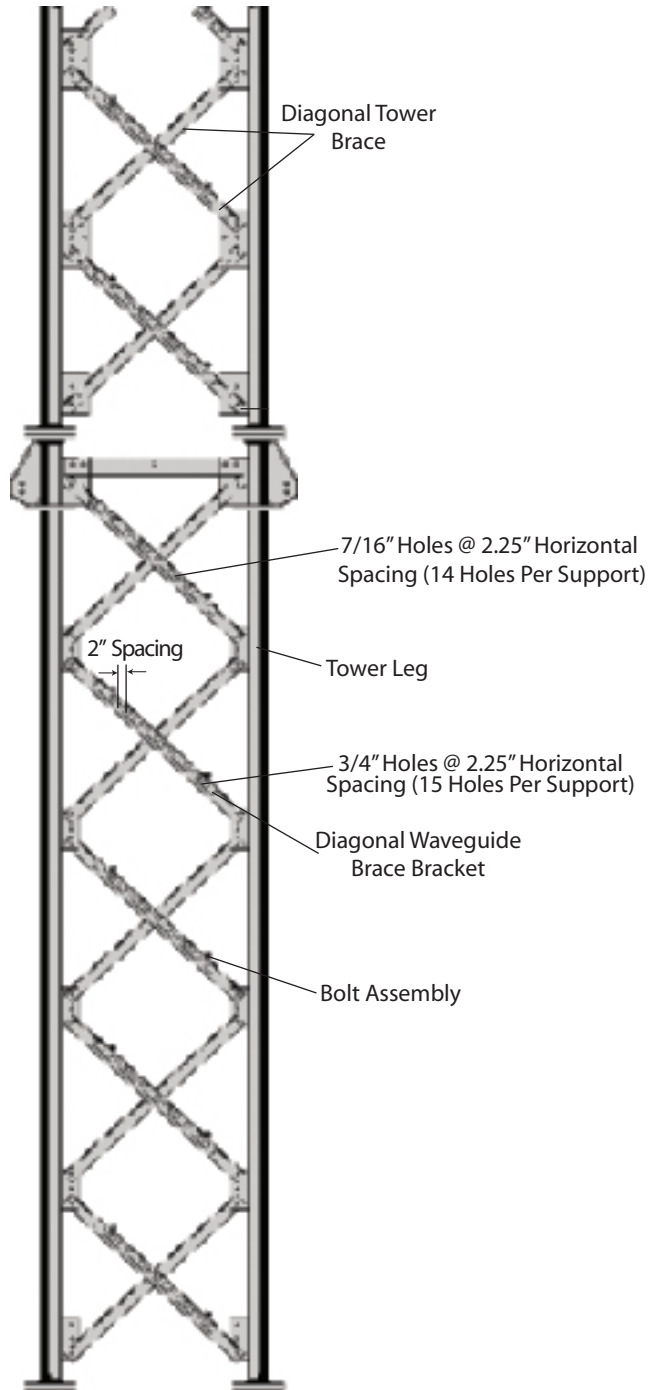

Angle Bracing

ORDERING INFORMATION

WAF901521
Angle Waveguide Support
& Bolt Assembly

Order (1) assembly part number WAF901521 for each diagonal brace bay that waveguides cross in a section. (Ex. (5) WAF901521 for a 20' tower section, (3) WAF901521 for a 12' tower section, etc.). This assembly may be mounted on outside of tower as shown or on inside as required.

HEAVY DUTY WAVEGUIDE BRIDGE

10' SINGLE / DOUBLE

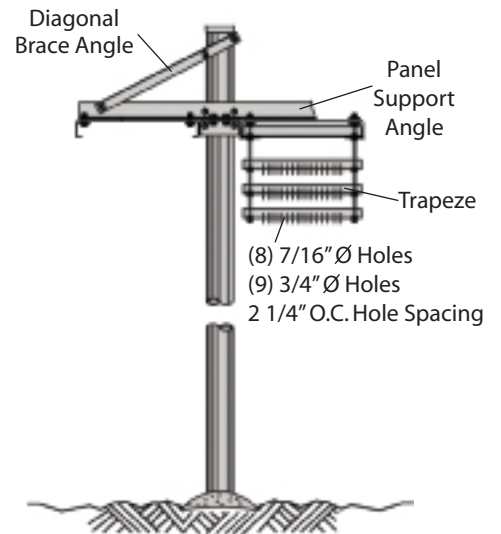
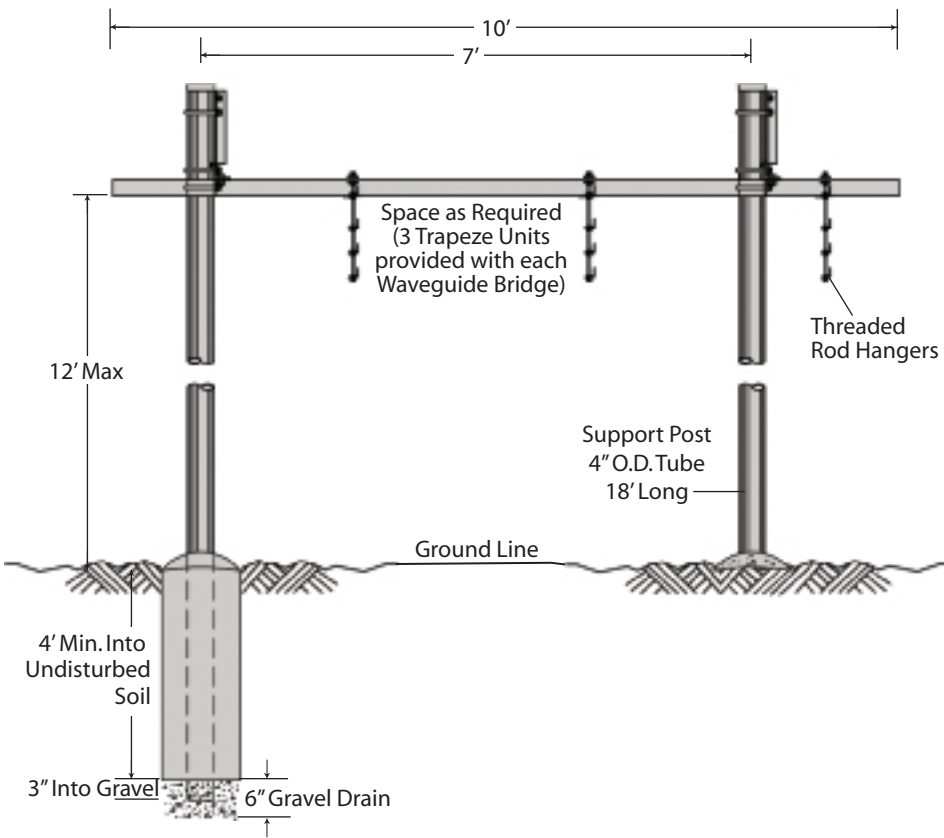
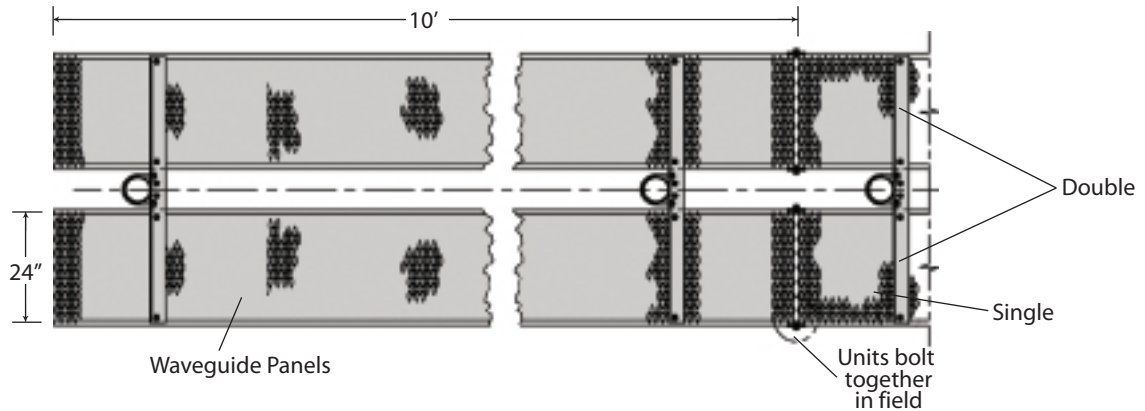

Notes:

1. Waveguide bridge is not designed to support personnel or equipment.

ORDERING INFORMATION

WGBS2410
Single Wide Bridge
2 Posts, 1 Bridge Panel (24" W x 10' L)
(3) Trapeze Units

WGBD2410
Double Bridge
2 Posts, 2 Bridge Panels (24" W x 10' L, each)
(6) Trapeze Units

LIGHT DUTY WAVEGUIDE BRIDGE
10' SINGLE / DOUBLE

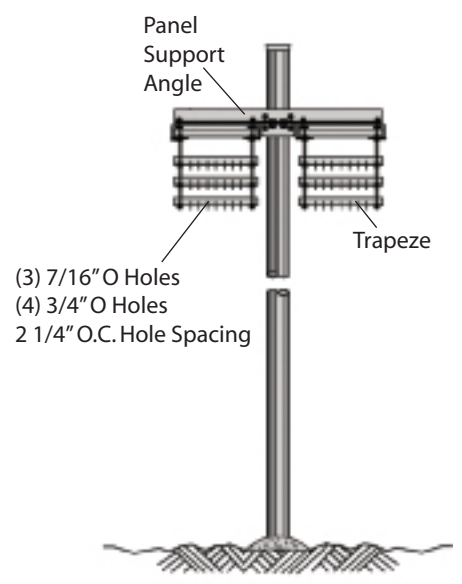
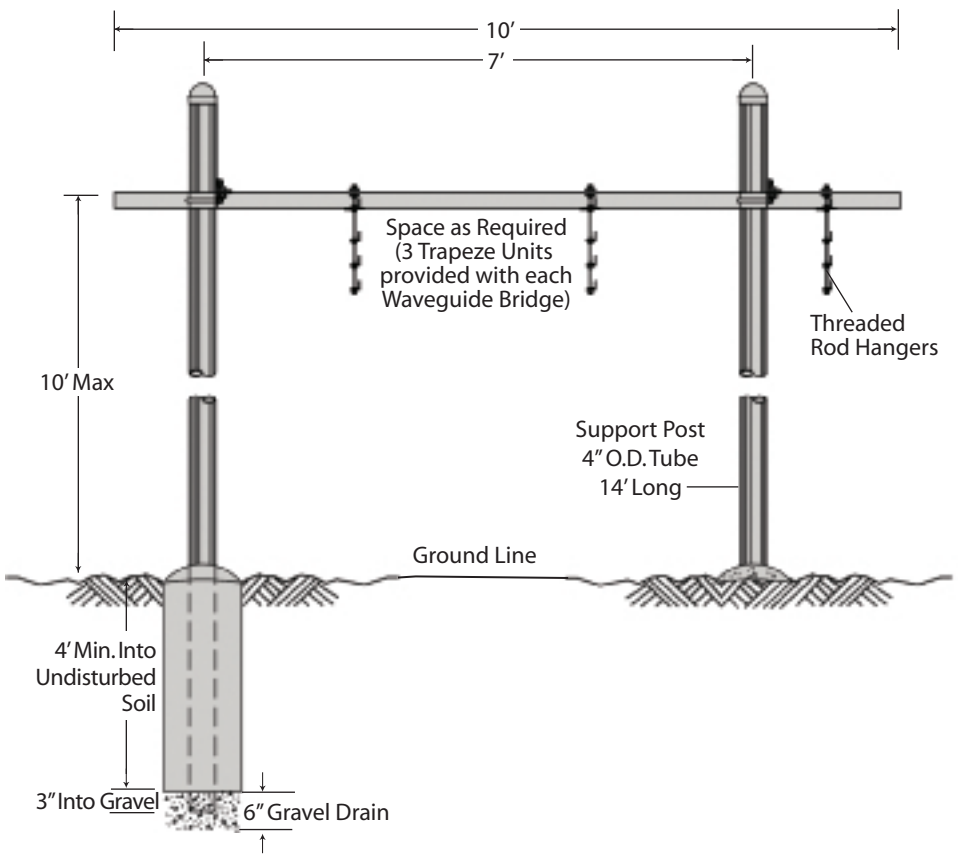
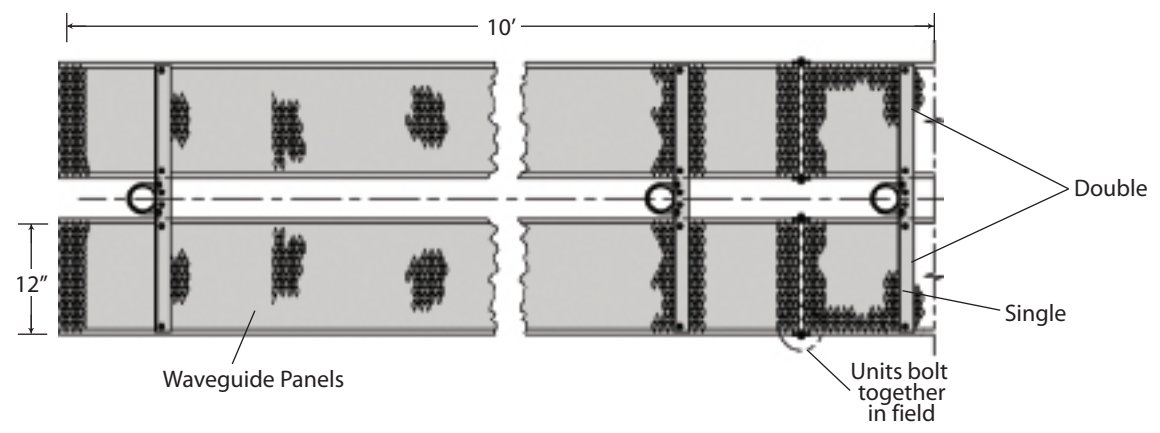

Notes:

1. Waveguide bridge is not designed to support personnel or equipment.

ORDERING INFORMATION

- WGBS121014**
Single Wide Bridge
2 Posts, 1 Bridge Panel (12" W x 10' L)
(3) Trapeze Units
- WGBD121014**
Double Bridge
2 Posts, 2 Bridge Panels (12" W x 10' L, each)
(6) Trapeze Units

POLES



DIRECT EMBED POLE
STANDARD DESIGNS

DIRECT EMBED POLES

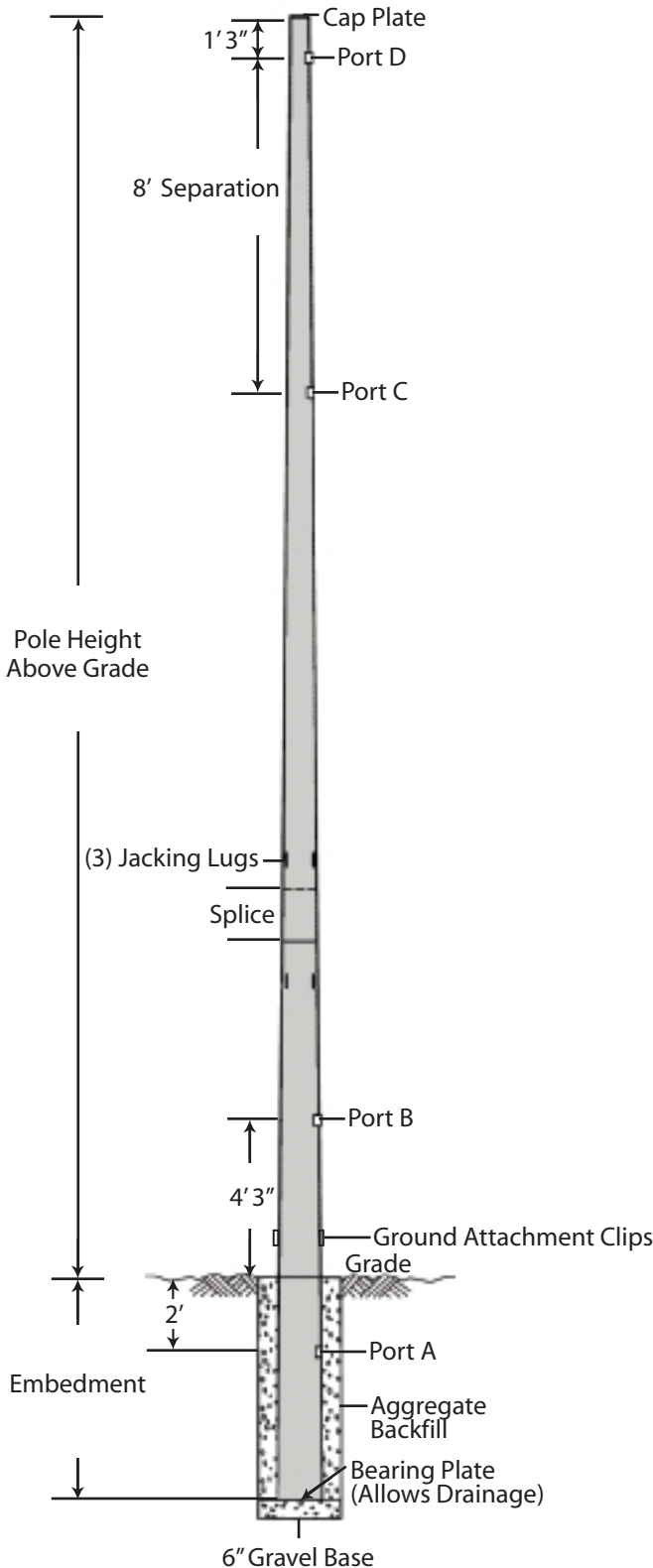

GENERAL USE

ROHN Direct Embed Poles minimize site requirements, lowering lease rates and acquisition costs. They are designed for rapid installation, meeting the demands of today's dynamic communication environments. Whether you are supporting broadband, PCS, security or other lightweight systems, ROHN Tapered Steel Poles offer extremely efficient designs.

FEATURES

- Completely hot-dip galvanized after fabrication
- Fast, easy installation
- Designed for applications with stringent deflection requirements
- Internal routing of transmission lines
- Each pole ships with the following:
 - Assembly Drawings and Standard Foundation Details
 - (4) 5" x 7" Ports with (2) port covers
 - (3) Jacking Lugs on each side of splices
 - (3) Ground attachment clips
 - (1) Vented cap plate
 - (1) Bearing plate welded to bottom
 - Safety Climb Support Brackets
 - (1) Safety warning sign
 - (1) Pole ID tag
 - Attachment clips for optional step bolts
- Optional items are available and may be ordered separately. Please see accessories on page 225.
- Custom designs available for any height or application.

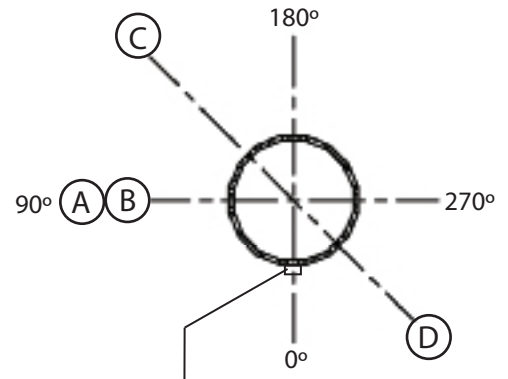

Per Rev G requirements, any structure greater than 10' requires a climber safety device. Please see page 225 for ordering information.

PORT ORIENTATIONS

BUYERS GUIDE

The pole loading charts included in this section were created to help you identify the standard pole that most closely meets your needs. The charts include the design wind speed, sway, total EPA that the pole can support and pole embedment requirements. Once the correct structure is identified, use the part number at the top of each section to order your pole.

Part Number for ordering direct embed poles

Sway at TIA operational wind speed

30'
Height Above Grade

WIND SPEED (MPH)		LIGHT			MEDIUM			HEAVY		
		DEP30LA			DEP30MA			DEP30HA		
FASTEST MILE	3-SECOND GUST	SWAY LIMIT			SWAY LIMIT			SWAY LIMIT		
		4°	3°	2°	4°	3°	2°	4°	3°	2°
		EPA (FT ²)			EPA (FT ²)			EPA (FT ²)		
70	85	69	49	29	110	108	68	170	170	143
80	100	52	49	29	80	80	68	126	126	126
90	110	38	38	29	59	59	59	95	95	95
100	120	27	27	27	44	44	44	74	74	74
110	130	19	19	19	32	32	32	57	57	57
120	140	13	13	13	24	24	24	45	45	45
EMBEDMENT		DEPTH 10'	DIA. 2.5'		DEPTH 11'	DIA. 2.5'		DEPTH 13'	DIA. 3.0'	

Total effective projected area of antennas, mounts and lighting allowed on pole (see pg. 226)

Depth and diameter of embedment for gravel backfill. Installation adds 6" to the depth for gravel base

LOADING CHARTS

40'

WIND SPEED (MPH)		LIGHT			MEDIUM			HEAVY		
		DEP40LA			DEP40MA			DEP40HA		
FASTEST MILE	3-SECOND GUST	SWAY LIMIT			SWAY LIMIT			SWAY LIMIT		
		4°	3°	2°	4°	3°	2°	4°	3°	2°
		EPA (FT ²)			EPA (FT ²)			EPA (FT ²)		
70	85	69	49	29	110	108	68	170	170	143
80	100	52	49	29	80	80	68	126	126	126
90	110	38	38	29	59	59	59	95	95	95
100	120	27	27	27	44	44	44	74	74	74
110	130	19	19	19	32	32	32	57	57	57
120	140	13	13	13	24	24	24	45	45	45
EMBEDMENT		DEPTH 12'	DIA. 2.5'		DEPTH 13'	DIA. 2.5'		DEPTH 15'	DIA. 3.0'	

50'

WIND SPEED (MPH)		LIGHT			MEDIUM			HEAVY		
		DEP50LA			DEP50MA			DEP50HA		
FASTEST MILE	3-SECOND GUST	SWAY LIMIT			SWAY LIMIT			SWAY LIMIT		
		4°	3°	2°	4°	3°	2°	4°	3°	2°
		EPA (FT ²)			EPA (FT ²)			EPA (FT ²)		
70	85	69	49	29	110	108	68	170	170	143
80	100	52	49	29	80	80	68	126	126	126
90	110	38	38	29	59	59	59	95	95	95
100	120	27	27	27	44	44	44	74	74	74
110	130	19	19	19	32	32	32	57	57	57
120	140	13	13	13	24	24	24	45	45	45
EMBEDMENT		DEPTH 15'	DIA. 2.5'		DEPTH 16'	DIA. 2.5'		DEPTH 17'	DIA. 3.0'	



LOADING CHARTS

60'

WIND SPEED (MPH)		LIGHT			MEDIUM			HEAVY					
		DEP60LA			DEP60MA			DEP60HA					
		SWAY LIMIT			SWAY LIMIT			SWAY LIMIT					
FASTEST MILE	3-SECOND GUST	4°	3°	2°	4°	3°	2°	4°	3°	2°			
		EPA (FT ²)			EPA (FT ²)			EPA (FT ²)					
70	85	52	35	19	99	80	48	150	150	104			
80	100	46	35	19	71	71	48	109	109	104			
90	110	32	32	19	50	50	48	81	81	81			
100	120	21	21	19	36	36	36	61	61	61			
110	130	14	14	14	25	25	25	46	46	46			
120	140	8	8	8	17	17	17	35	35	35			
EMBEDMENT		DEPTH	15'	DIA.	2.5'	DEPTH	17'	DIA.	3.0'	DEPTH	19'	DIA.	3.0'

70'

WIND SPEED (MPH)		LIGHT			MEDIUM			HEAVY					
		DEP70LA			DEP70MA			DEP70HA					
		SWAY LIMIT			SWAY LIMIT			SWAY LIMIT					
FASTEST MILE	3-SECOND GUST	4°	3°	2°	4°	3°	2°	4°	3°	2°			
		EPA (FT ²)			EPA (FT ²)			EPA (FT ²)					
70	85	42	28	13	89	63	36	137	129	81			
80	100	42	28	13	63	63	36	98	98	81			
90	110	28	28	13	43	43	36	72	73	73			
100	120	17	17	13	29	29	29	53	53	53			
110	130	9	9	9	19	19	19	39	39	39			
120	140	3	3	3	10	10	10	28	28	28			
EMBEDMENT		DEPTH	16'	DIA.	3.0'	DEPTH	18'	DIA.	3.0'	DEPTH	20'	DIA.	3.5'

80'

WIND SPEED (MPH)		LIGHT			MEDIUM			HEAVY					
		DEP80LA			DEP80MA			DEP80HA					
		SWAY LIMIT			SWAY LIMIT			SWAY LIMIT					
FASTEST MILE	3-SECOND GUST	4°	3°	2°	4°	3°	2°	4°	3°	2°			
		EPA (FT ²)			EPA (FT ²)			EPA (FT ²)					
70	85	28	17	6	65	44	23	117	93	56			
80	100	28	17	6	50	44	23	82	82	56			
90	110	19	17	6	32	32	23	58	58	56			
100	120	9	9	6	19	19	19	41	41	41			
110	130	2	2	2	9	9	9	28	28	28			
120	140	-	-	-	2	2	2	18	18	18			
EMBEDMENT		DEPTH	16'	DIA.	3.0'	DEPTH	18'	DIA.	3.0'	DEPTH	20'	DIA.	3.5'

90'

WIND SPEED (MPH)		LIGHT			MEDIUM			HEAVY					
		DEP90LA			DEP90MA			DEP90HA					
		SWAY LIMIT			SWAY LIMIT			SWAY LIMIT					
FASTEST MILE	3-SECOND GUST	4°	3°	2°	4°	3°	2°	4°	3°	2°			
		EPA (FT ²)			EPA (FT ²)			EPA (FT ²)					
70	85	21	11	2	51	33	16	106	77	44			
80	100	21	11	2	43	33	16	73	73	44			
90	110	14	11	2	25	25	16	50	50	44			
100	120	4	4	2	12	12	12	33	33	33			
110	130	-	-	2	3	3	3	21	21	21			
120	140	-	-	-	-	-	-	13	13	13			
EMBEDMENT		DEPTH	18'	DIA.	3.0'	DEPTH	20'	DIA.	3.0'	DEPTH	22'	DIA.	3.5'

(-) Indicates that pole is not recommended for the tabulated wind speed



LOADING CHARTS

100'

WIND SPEED (MPH)		LIGHT			MEDIUM			HEAVY		
		DEP100LA			DEP100MA			DEP100HA		
		SWAY LIMIT			SWAY LIMIT			SWAY LIMIT		
FASTEST MILE	3-SECOND GUST	4°	3°	2°	4°	3°	2°	4°	3°	2°
		EPA (FT ²)			EPA (FT ²)			EPA (FT ²)		
70	85	16	7	-	42	26	11	91	63	36
80	100	16	7	-	36	26	11	65	63	36
90	110	9	7	-	18	18	11	43	43	36
100	120	-	-	-	6	6	6	26	26	26
110	130	-	-	-	-	-	-	14	14	14
120	140	-	-	-	-	-	-	7	7	7
EMBEDMENT		DEPTH 18'	DIA. 3.0'		DEPTH 20'	DIA. 3.5'		DEPTH 22'	DIA. 3.5'	

110'

WIND SPEED (MPH)		LIGHT			MEDIUM			HEAVY		
		DEP110LA			DEP110MA			DEP110HA		
		SWAY LIMIT			SWAY LIMIT			SWAY LIMIT		
FASTEST MILE	3-SECOND GUST	4°	3°	2°	4°	3°	2°	4°	3°	2°
		EPA (FT ²)			EPA (FT ²)			EPA (FT ²)		
70	85	23	13	-	51	32	14	103	70	41
80	100	23	13	-	47	32	14	77	70	41
90	110	13	13	-	25	25	14	50	50	41
100	120	-	-	-	9	9	9	31	31	31
110	130	-	-	-	-	-	-	17	17	17
120	140	-	-	-	-	-	-	8	8	8
EMBEDMENT		DEPTH 19'	DIA. 3.5'		DEPTH 21'	DIA. 4.0'		DEPTH 22'	DIA. 4.0'	

120'

WIND SPEED (MPH)		LIGHT			MEDIUM			HEAVY		
		DEP120LA			DEP120MA			DEP120HA		
		SWAY LIMIT			SWAY LIMIT			SWAY LIMIT		
FASTEST MILE	3-SECOND GUST	4°	3°	2°	4°	3°	2°	4°	3°	2°
		EPA (FT ²)			EPA (FT ²)			EPA (FT ²)		
70	85	18	10	-	39	24	6	90	62	35
80	100	18	10	-	36	24	6	80	62	35
90	110	5	5	-	15	15	6	55	55	35
100	120	-	-	-	-	-	-	36	36	35
110	130	-	-	-	-	-	-	23	23	23
120	140	-	-	-	-	-	-	14	14	14
EMBEDMENT		DEPTH 19'	DIA. 3.5'		DEPTH 22'	DIA. 4.0'		DEPTH 23'	DIA. 4.0'	

130'

WIND SPEED (MPH)		LIGHT			MEDIUM			HEAVY		
		DEP130LA			DEP130MA			DEP130HA		
		SWAY LIMIT			SWAY LIMIT			SWAY LIMIT		
FASTEST MILE	3-SECOND GUST	4°	3°	2°	4°	3°	2°	4°	3°	2°
		EPA (FT ²)			EPA (FT ²)			EPA (FT ²)		
70	85	19	8	-	39	24	6	83	57	30
80	100	19	8	-	39	24	6	76	57	30
90	110	14	8	-	24	24	6	51	51	30
100	120	2	2	-	11	11	6	32	32	30
110	130	-	-	-	-	-	-	21	21	21
120	140	-	-	-	-	-	-	10	10	10
EMBEDMENT		DEPTH 22'	DIA. 4.0'		DEPTH 23'	DIA. 4.0'		DEPTH 24'	DIA. 4.5'	

(-) Indicates that pole is not recommended for the tabulated wind speed



LOADING CHARTS

140'

WIND SPEED (MPH)		LIGHT			MEDIUM			HEAVY		
		DEP140LA			DEP140MA			DEP140HA		
		SWAY LIMIT			SWAY LIMIT			SWAY LIMIT		
FASTEST MILE	3-SECOND GUST	4°	3°	2°	4°	3°	2°	4°	3°	2°
		EPA (FT ²)			EPA (FT ²)			EPA (FT ²)		
70	85	16	5	-	42	26	6	86	62	31
80	100	16	5	-	42	26	6	86	62	31
90	110	8	5	-	36	26	6	66	62	31
100	120	-	-	-	16	16	6	45	45	31
110	130	-	-	-	-	-	-	28	28	28
120	140	-	-	-	-	-	-	13	13	13
EMBEDMENT		DEPTH 24'	DIA. 4.0'		DEPTH 25'	DIA. 4.5'		DEPTH 26'	DIA. 4.5'	



150'

WIND SPEED (MPH)		LIGHT			MEDIUM			HEAVY		
		DEP150LA			DEP150MA			DEP150HA		
		SWAY LIMIT			SWAY LIMIT			SWAY LIMIT		
FASTEST MILE	3-SECOND GUST	4°	3°	2°	4°	3°	2°	4°	3°	2°
		EPA (FT ²)			EPA (FT ²)			EPA (FT ²)		
70	85	17	5	-	47	26	6	89	63	31
80	100	17	5	-	47	26	6	89	63	31
90	110	17	5	-	30	26	6	65	63	31
100	120	-	-	-	10	10	6	39	39	31
110	130	-	-	-	-	-	-	22	22	22
120	140	-	-	-	-	-	-	6	6	6
EMBEDMENT		DEPTH 24'	DIA. 4.0'		DEPTH 26'	DIA. 4.5'		DEPTH 27'	DIA. 5.0'	

(-) Indicates that pole is not recommended for the tabulated wind speed

1. Pole designs conform to ANSI/TIA/EIA-222-F with 1/2" radial ice and to ANSI/TIA-222-G (Class I, Exposure B, Topographic Category I). Design criteria must be verified prior to installation based on site-specific requirements.
2. Embedment depths are based on "Normal" soil (TIA Rev. F) and clay "Presumptive" soil (TIA Rev. G) with aggregate backfill. Actual site soil design parameters must be verified prior to installation.
3. For corrosive groundwater and/or soil conditions, ROHN recommends additional corrosion control protection such as concrete backfill, additional protective coating over galvanizing or the installation of sacrificial anodes.
4. Embedment depths may require adjustment based on local soil conditions.

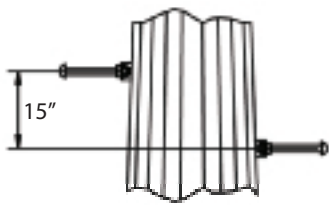
PARTS & ACCESSORIES

 <p>STEP BOLTS</p> <p>STEP BOLTS START AT 20' ABOVE GRADE (NOMINAL). WHEN ORDERING STEP BOLTS, PLEASE SPECIFY POLE HEIGHT.</p> <p>EX. SBDEP120 for a 120' POLE</p>	 <p>JOURNEYMAN CLIMBING HARNESS TTFBH-4D</p> <p>PROFESSIONAL CLIMBING HARNESS TTFBH-C/P</p>	 <p>SAFETY CABLE SLIDER WITH CARABINEER TT-WG-500-W/SMC</p>	<p>SAFETY CABLE SYSTEM</p> <table border="1"> <thead> <tr> <th>Pole Height</th> <th>Part Number</th> </tr> </thead> <tbody> <tr> <td>30' - 50'</td> <td>TT050TSP</td> </tr> <tr> <td>60' - 100'</td> <td>TT100TSP</td> </tr> <tr> <td>110' - 150'</td> <td>TT150TSP</td> </tr> </tbody> </table>	Pole Height	Part Number	30' - 50'	TT050TSP	60' - 100'	TT100TSP	110' - 150'	TT150TSP
Pole Height	Part Number										
30' - 50'	TT050TSP										
60' - 100'	TT100TSP										
110' - 150'	TT150TSP										

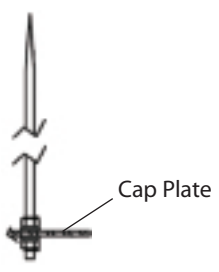

LIGHTNING ROD
LRCL
5' COPPER CLAD BOLTS TO CAP PLATE, PROVIDED WITH POLE.

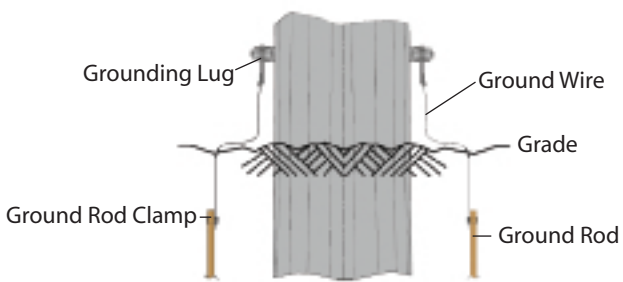

GROUNDING KIT
BGK5GGX
KIT INCLUDES (1) GROUND LEAD, GROUND ROD AND CONNECTIONS. ORDER (3) KITS FOR REV G GROUNDING.

PORT DIMENSIONS

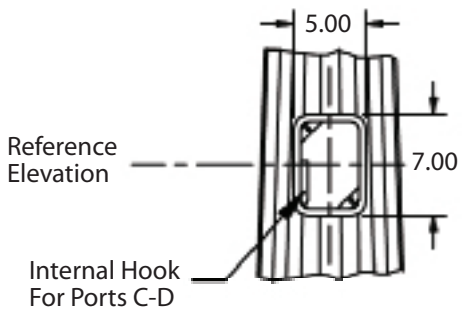

A through D PORTS
Larger ports are available, upon request.



ANTENNA INDEX

DISH ANTENNA			
DIAMETER	EPA - FT ²		SWAY LIMIT
	W/ RADOME	W/O RADOME	
(1) 2 FT.	3	6	4°
(1) 3 FT.	7	13	3°
(1) 4 FT.	11	22	2°
(2) 2 FT. B-TO-B	5	8	4°
(2) 3 FT. B-TO-B	11	18	3°
(2) 4 FT. B-TO-B	19	34	2°

FLAT PANEL ANTENNA		
DIMENSION	EPA - FT ²	SWAY LIMIT
1 FT. SQUARE W/ MOUNT	2	4°
2 FT. SQUARE W/ MOUNT	5	2°
3 FT. SQUARE W/ MOUNT	11	2°

1. The above antenna data is intended to assist in the selection of the appropriate ROHN pole. Once the total EPA and sway limit is determined for the antennas, the standard ROHN pole can be selected from the tabulated values. (See example below)
2. Tabulated pole EPA capacities represent the maximum EPA capacity of a pole. The capacity is based on the assumption that 80% of the total EPA is located at the top of the pole and the remaining 20% is located 20 ft. below the top. When all loading is located at the top of the pole, the tabulated EPA capacity must be reduced by 20%.
3. Sway limits are determined under a 50 MPH fastest-mile (Rev. F) or 60 MPH 3-second gust (Rev. G) wind speed.
4. The antenna effective projected areas (EPA) and sway limits provided in the antenna index are guidelines for typical antenna systems. Other values may apply for specific antenna models or for site-specific systems.

Determine EPA & Sway Limit for Dishes or Flat Panel Antennas

1. Using the antenna index, determine the types of antennas to be installed on the pole.
2. Add together the EPA value of all the antennas to be supported.
3. Determine the most restrictive sway limit considering all the antennas to be supported. For example, for one 3' dish with a 3° sway limit and one 1' flat panel with a 4° sway limit, the sway limit for the pole would be 3° and the required pole EPA capacity would be 13+2=15 ft².
4. If all antennas are to be supported at the top of the pole, only 80% of the tabulated EPA capacity shown may be considered when selecting a pole. Alternately, the antenna EPA to be supported may be increased by 25%. For example, the required pole capacity would be 15x1.25=19 ft².
5. Using the pole sway limit and the required EPA capacities, the appropriate pole may be determined from the tabulated values. For example, for a 120 ft. pole and a 100 mph 3-sec gust wind speed, a medium pole [P/N: DEP120MA] would be required for an EPA capacity greater than 19 ft² for a 3° sway limit.

PRE-ENGINEERED UTILITY POLES



PRE-ENGINEERED UTILITY POLES

GENERAL USE

ROHN Pre-Engineered steel utility poles offer a light duty solution to satisfy utilities desiring an alternative to wood poles. ROHN's line of Pre-Engineered poles are lighter than typical wooden and concrete poles and provide easy installation and low maintenance. ROHN offers Pre-Engineered poles for either direct embed or flange installations. The poles come standard with a hot-dip galvanized coating, but can also be painted or fabricated with weathering steel.

FEATURES

- Fast, easy installation
- Each pole ships with the following:
 - Standard ground sleeve (at grade)
 - Standard sub-grade corrosion coating to 6" above grade
 - Cap plate
 - (2) 4" Nema Ground Lugs
 - Bearing Plate with drain hole
 - Jacking Lugs (at slip splices)
- Optional items are available and may be ordered separately:
 - Step attachment clips
 - Climbing pegs / step bolts
 - Safety climb device
 - Port holes
 - Flanged base
 - Painted finish
- Custom designs are available for any height or application.



BUYERS GUIDE

H 1 0 R P (18,400# / 11,500#)

TOTAL LENGTH (FT) "L"	TIP AGL (FT)	PART NUMBER	TIP DIAMETER (IN)	BASE DIAMETER (IN)	SLOPE (IN/FT)	NO. SECTIONS	WEIGHT (LBS)	OVERTURNING MOMENT CAPACITY (FT-KIP)
40	34.0	H10RP040	12.0	21.2	0.230	1	1945	368
45	38.5	H10RP045	12.0	22.4	0.231	1	2253	420
50	43.0	H10RP050	12.0	23.5	0.230	1	2581	472
55	47.5	H10RP055	12.0	25.1	0.238	2	3074	523
60	52.0	H10RP060	12.0	26.3	0.238	2	3440	576
65	56.5	H10RP065	12.0	27.6	0.240	2	3896	627
70	61.0	H10RP070	12.0	28.8	0.240	2	4304	680
75	65.5	H10RP075	12.0	30.1	0.241	2	4765	730
80	70.0	H10RP080	12.0	31.3	0.241	2	5210	785
85	74.5	H10RP085	12.0	32.6	0.242	2	5666	834
90	79.0	H10RP090	12.0	33.8	0.242	2	6148	890
95	83.5	H10RP095	12.0	34.4	0.236	3	6779	937
100	88.0	H10RP100	12.0	35.7	0.237	3	7282	995
105	92.5	H10RP105	12.0	36.9	0.237	3	7918	1041
110	97.0	H10RP110	12.0	38.2	0.238	3	8459	1100
115	101.5	H10RP115	12.0	39.4	0.238	3	9153	1141
120	106.0	H10RP120	12.0	40.7	0.239	3	9731	1206

OTM @ 5' = 183 ft-kips

Overturning moment capacity at 5' below tip.

The part number shown in the chart includes the pole loading and the overall length of the structure. The coating suffix (**W** or **G**) is added by the customer at the time of the order, along with any optional items (flanged base, step clips and safety device, ports, special grounding lugs, special ground sleeves and paint).

The example below provides a guide, for ordering convenience.

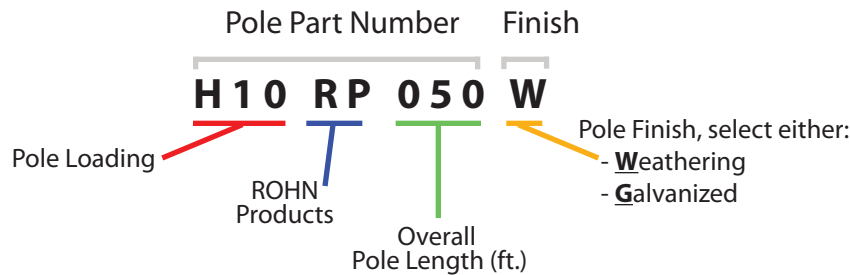

Diameters are out-to-out width between flats. Slope is change in diameter per foot of length. Overturning moment capacity is at grade.

In the example shown, the customer is purchasing an H10RP, with an overall length of 50'. The pole is to be constructed of Weathering Steel, with a Direct Embed Base.

NOTE: Values in () indicate horizontal factored loads applied 2' from the tip.

H 1 0 R P (18,400# / 11,500#)

Equivalent factored load for wood poles

Factored load for steel poles

Embedment depths illustrated may require adjustment based on local soil conditions.

PRODUCT DATA

C 1 R P (4,500# / 2,812#)

TOTAL LENGTH (FT) "L"	TIP AGL (FT)	PART NUMBER	TIP DIAMETER (IN)	BASE DIAMETER (IN)	SLOPE (IN/FT)	NO. SECTIONS	WEIGHT (LB)	OVERTURNING MOMENT CAPACITY (FT-KIP)
40	34.0	C1RP040	7.5	13.1	0.140	1	981	91
45	38.5	C1RP045	7.5	13.1	0.124	1	1092	103
50	43.0	C1RP050	7.5	13.1	0.112	1	1201	117
55	47.5	C1RP055	7.5	14.8	0.133	2	1442	128
60	52.0	C1RP060	7.5	14.8	0.122	2	1553	143
65	56.5	C1RP065	7.5	17.2	0.149	2	1876	153
70	61.0	C1RP070	7.5	17.2	0.139	2	1999	169
75	65.5	C1RP075	7.5	19.5	0.160	2	2337	179
80	70.0	C1RP080	7.5	19.5	0.150	2	2477	196
85	74.5	C1RP085	7.5	21.3	0.162	2	2840	204
90	79.0	C1RP090	7.5	21.3	0.153	2	2937	223
95	83.5	C1RP095	7.5	23.7	0.171	3	3403	229
100	88.0	C1RP100	7.5	23.7	0.162	3	3560	250
105	92.5	C1RP105	7.5	25.7	0.173	3	4033	267
110	97.0	C1RP110	7.5	25.7	0.165	3	4197	277
115	101.5	C1RP115	7.5	27.5	0.174	3	4643	280
120	106.0	C1RP120	7.5	27.5	0.167	3	4820	305

OTM @ 5' = 51 ft-kips

C 2 R P (3,700# / 2,313#)

TOTAL LENGTH (FT) "L"	TIP AGL (FT)	PART NUMBER	TIP DIAMETER (IN)	BASE DIAMETER (IN)	SLOPE (IN/FT)	NO. SECTIONS	WEIGHT (LB)	OVERTURNING MOMENT CAPACITY (FT-KIP)
40	34.0	C2RP040	7.5	13.1	0.140	1	981	75
45	38.5	C2RP045	7.5	14.5	0.156	1	1161	84
50	43.0	C2RP050	7.5	14.5	0.140	1	1277	96
55	47.5	C2RP055	7.5	15.9	0.153	2	1505	105
60	52.0	C2RP060	7.5	15.9	0.140	2	1629	116
65	56.5	C2RP065	7.5	17.3	0.151	2	1882	137
70	61.0	C2RP070	7.5	17.3	0.140	2	2007	147
75	65.5	C2RP075	7.5	18.7	0.149	2	2274	157
80	70.0	C2RP080	7.5	18.7	0.140	2	2406	168
85	74.5	C2RP085	7.5	20.1	0.148	2	2674	178
90	79.0	C2RP090	7.5	20.1	0.140	2	2818	189
95	83.5	C2RP095	7.5	22.0	0.153	3	3222	199
100	88.0	C2RP100	7.5	22.0	0.145	3	3368	209
105	92.5	C2RP105	7.5	23.7	0.154	3	3774	215
110	97.0	C2RP110	7.5	23.7	0.147	3	3928	220
115	101.5	C2RP115	7.5	25.5	0.157	3	4383	230
120	106.0	C2RP120	7.5	25.5	0.150	3	4547	241

OTM @ 5' = 53 ft-kips

C 3 R P (3,000# / 1,875#)

TOTAL LENGTH (FT) "L"	TIP AGL (FT)	PART NUMBER	TIP DIAMETER (IN)	BASE DIAMETER (IN)	SLOPE (IN/FT)	NO. SECTIONS	WEIGHT (LB)	OVERTURNING MOMENT CAPACITY (FT-KIP)
40	34.0	C3RP040	7.5	13.1	0.140	1	981	61
45	38.5	C3RP045	7.5	14.5	0.156	1	1161	68
50	43.0	C3RP050	7.5	14.5	0.140	1	1277	78
55	47.5	C3RP055	7.5	15.9	0.153	2	1505	85
60	52.0	C3RP060	7.5	15.9	0.140	2	1626	96
65	56.5	C3RP065	7.5	17.3	0.151	2	1882	102
70	61.0	C3RP070	7.5	17.3	0.140	2	2007	113
75	65.5	C3RP075	7.5	18.7	0.149	2	2274	119
80	70.0	C3RP080	7.5	18.7	0.140	2	2406	131
85	74.5	C3RP085	7.5	20.1	0.148	2	2677	136
90	79.0	C3RP090	7.5	20.1	0.140	2	2818	144
95	83.5	C3RP095	7.5	21.5	0.147	3	3169	153
100	88.0	C3RP100	7.5	21.5	0.140	3	3312	161
105	92.5	C3RP105	7.5	22.9	0.147	3	3678	170
110	97.0	C3RP110	7.5	22.9	0.140	3	3828	178
115	101.5	C3RP115	7.5	24.3	0.146	3	4224	187
120	106.0	C3RP120	7.5	24.3	0.140	3	4384	195

OTM @ 5' = 53 ft-kips

7.5" Tip

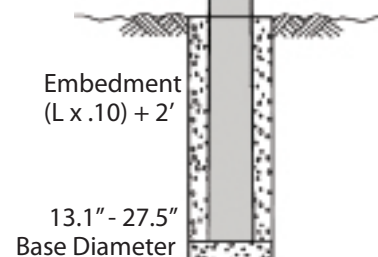



PRODUCT DATA

H 1 R P (5,400# / 3,375#)

TOTAL LENGTH (FT) "L"	TIP AGL (FT)	PART NUMBER	TIP DIAMETER (IN)	BASE DIAMETER (IN)	SLOPE (IN/FT)	NO. SECTIONS	WEIGHT (LB)	OVERTURNING MOMENT CAPACITY (FT-KIP)
40	34.0	H1RP040	7.5	13.1	0.140	1	981	109
45	38.5	H1RP045	7.5	14.2	0.149	1	1161	138
50	43.0	H1RP050	7.5	14.2	0.134	1	1261	140
55	47.5	H1RP055	7.5	16.0	0.155	2	1516	153
60	52.0	H1RP060	7.5	16.0	0.142	2	1636	171
65	56.5	H1RP065	7.5	18.5	0.169	2	1966	184
70	61.0	H1RP070	7.5	18.5	0.157	2	2102	202
75	65.5	H1RP075	7.5	21.0	0.180	2	2465	214
80	70.0	H1RP080	7.5	21.0	0.169	2	2611	234
85	74.5	H1RP085	7.5	23.0	0.182	2	2952	245
90	79.0	H1RP090	7.5	23.0	0.172	2	3092	246
95	83.5	H1RP095	7.5	26.0	0.195	3	3705	278
100	88.0	H1RP100	7.5	26.0	0.185	3	3872	298
105	92.5	H1RP105	7.5	28.0	0.195	3	4309	305
110	97.0	H1RP110	7.5	28.0	0.186	3	4488	330
115	101.5	H1RP115	7.5	29.5	0.191	3	4950	336
120	106.0	H1RP120	7.5	29.5	0.183	3	5133	363

OTM @ 5' = 52 ft-kips

H 2 R P (6,400# / 4,000#)

TOTAL LENGTH (FT) "L"	TIP AGL (FT)	PART NUMBER	TIP DIAMETER (IN)	BASE DIAMETER (IN)	SLOPE (IN/FT)	NO. SECTIONS	WEIGHT (LB)	OVERTURNING MOMENT CAPACITY (FT-KIP)
40	34.0	H2RP040	7.8	13.6	0.145	1	1016	129
45	38.5	H2RP045	7.8	16.0	0.182	1	1251	146
50	43.0	H2RP050	7.8	16.0	0.164	1	1375	165
55	47.5	H2RP055	7.8	17.5	0.176	2	1638	182
60	52.0	H2RP060	7.8	17.5	0.162	2	1765	202
65	56.5	H2RP065	7.8	19.4	0.178	2	2056	218
70	61.0	H2RP070	7.8	19.4	0.166	2	2194	239
75	65.5	H2RP075	7.8	22.0	0.189	2	2592	254
80	70.0	H2RP080	7.8	22.0	0.178	2	2744	277
85	74.5	H2RP085	7.8	24.5	0.196	2	3138	290
90	79.0	H2RP090	7.8	24.5	0.186	2	3304	314
95	83.5	H2RP095	7.8	27.3	0.205	3	3880	326
100	88.0	H2RP100	7.8	27.3	0.195	3	4055	352
105	92.5	H2RP105	7.8	29.4	0.206	3	4510	362
110	97.0	H2RP110	7.8	29.4	0.196	3	4698	390
115	101.5	H2RP115	7.8	31.4	0.205	3	5236	398
120	106.0	H2RP120	7.8	31.4	0.197	3	5433	428

OTM @ 5' = 57 ft-kips

H 3 R P (7,500# / 4,688#)

TOTAL LENGTH (FT) "L"	TIP AGL (FT)	PART NUMBER	TIP DIAMETER (IN)	BASE DIAMETER (IN)	SLOPE (IN/FT)	NO. SECTIONS	WEIGHT (LB)	OVERTURNING MOMENT CAPACITY (FT-KIP)
40	34.0	H3RP040	8.0	14.8	0.170	1	1077	150
45	38.5	H3RP045	8.0	17.0	0.200	1	1309	171
50	43.0	H3RP050	8.0	17.0	0.180	1	1440	193
55	47.5	H3RP055	8.0	18.8	0.196	2	1728	213
60	52.0	H3RP060	8.0	18.8	0.180	2	1865	235
65	56.5	H3RP065	8.0	21.0	0.200	2	2184	255
70	61.0	H3RP070	8.0	21.0	0.186	2	2335	278
75	65.5	H3RP075	8.0	23.2	0.203	2	2708	298
80	70.0	H3RP080	8.0	23.2	0.190	2	2870	321
85	74.5	H3RP085	8.0	26.0	0.212	2	3302	340
90	79.0	H3RP090	8.0	26.0	0.200	2	3475	365
95	83.5	H3RP095	8.0	28.6	0.217	3	4044	382
100	88.0	H3RP100	8.0	28.6	0.206	3	4226	407
105	92.5	H3RP105	8.0	31.2	0.221	3	4775	424
110	97.0	H3RP110	8.0	31.2	0.211	3	4973	451
115	101.5	H3RP115	8.0	33.0	0.217	3	5480	466
120	106.0	H3RP120	8.0	33.0	0.208	3	5684	494

OTM @ 5' = 62 ft-kips

7.5" - 8" Tip

Embedment
(L x .10) + 2'

13.1" - 33"
Base Diameter



PRODUCT DATA

H 4 R P (8,700# / 5,438#)

TOTAL LENGTH (FT) "L"	TIP AGL (FT)	PART NUMBER	TIP DIAMETER (IN)	BASE DIAMETER (IN)	SLOPE (IN/FT)	NO. SECTIONS	WEIGHT (LB)	OVERTURNING MOMENT CAPACITY (FT-KIP)
40	34.0	H4RP040	8.5	16.5	0.200	1	1116	174
45	38.5	H4RP045	8.5	18.2	0.216	1	1336	199
50	43.0	H4RP050	8.5	18.2	0.194	1	1476	223
55	47.5	H4RP055	8.5	20.2	0.213	2	1786	247
60	52.0	H4RP060	8.5	20.2	0.195	2	1935	273
65	56.5	H4RP065	8.5	22.2	0.211	2	2253	296
70	61.0	H4RP070	8.5	22.2	0.196	2	2410	322
75	65.5	H4RP075	8.5	24.3	0.211	2	2788	345
80	70.0	H4RP080	8.5	24.3	0.198	2	2956	372
85	74.5	H4RP085	8.5	27.2	0.220	2	3403	394
90	79.0	H4RP090	8.5	27.2	0.208	2	3589	421
95	83.5	H4RP095	8.5	30.0	0.226	3	4171	443
100	88.0	H4RP100	8.5	30.0	0.215	3	4365	471
105	92.5	H4RP105	8.5	32.3	0.227	3	4929	492
110	97.0	H4RP110	8.5	32.3	0.216	3	5137	522
115	101.5	H4RP115	8.5	34.9	0.230	3	5766	541
120	106.0	H4RP120	8.5	34.9	0.220	3	5985	572

OTM @ 5' = 71 ft-kips

H 5 R P (10,000# / 6,250#)

TOTAL LENGTH (FT) "L"	TIP AGL (FT)	PART NUMBER	TIP DIAMETER (IN)	BASE DIAMETER (IN)	SLOPE (IN/FT)	NO. SECTIONS	WEIGHT (LB)	OVERTURNING MOMENT CAPACITY (FT-KIP)
40	34.0	H5RP040	9.0	17.5	0.213	1	1181	200
45	38.5	H5RP045	9.0	20.0	0.244	1	1447	228
50	43.0	H5RP050	9.0	20.0	0.220	1	1601	257
55	47.5	H5RP055	9.0	22.0	0.236	2	1929	284
60	52.0	H5RP060	9.0	22.0	0.217	2	2090	314
65	56.5	H5RP065	9.0	24.3	0.235	2	2459	341
70	61.0	H5RP070	9.0	24.3	0.219	2	2631	371
75	65.5	H5RP075	9.0	26.5	0.233	2	3016	397
80	70.0	H5RP080	9.0	26.5	0.219	2	3198	429
85	74.5	H5RP085	9.0	29.0	0.235	2	3625	453
90	79.0	H5RP090	9.0	29.0	0.222	2	3820	487
95	83.5	H5RP095	9.0	31.7	0.239	3	4436	509
100	88.0	H5RP100	9.0	31.7	0.227	3	4640	545
105	92.5	H5RP105	9.0	34.3	0.241	3	5231	566
110	97.0	H5RP110	9.0	34.3	0.230	3	5449	603
115	101.5	H5RP115	9.0	37.0	0.243	3	6137	622
120	106.0	H5RP120	9.0	37.0	0.233	3	6365	662

OTM @ 5' = 80 ft-kips

H 6 R P (11,400# / 7,125#)

TOTAL LENGTH (FT) "L"	TIP AGL (FT)	PART NUMBER	TIP DIAMETER (IN)	BASE DIAMETER (IN)	SLOPE (IN/FT)	NO. SECTIONS	WEIGHT (LB)	OVERTURNING MOMENT CAPACITY (FT-KIP)
40	34.0	H6RP040	9.0	18.3	0.230	1	1211	228
45	38.5	H6RP045	9.0	21.0	0.267	1	1495	260
50	43.0	H6RP050	9.0	21.0	0.240	1	1655	292
55	47.5	H6RP055	9.0	23.2	0.258	2	2003	324
60	52.0	H6RP060	9.0	23.4	0.237	2	2173	357
65	56.5	H6RP065	9.0	25.7	0.257	2	2565	388
70	61.0	H6RP070	9.0	25.9	0.239	2	2741	421
75	65.5	H6RP075	9.0	28.3	0.257	2	3191	452
80	70.0	H6RP080	9.0	28.3	0.241	2	3381	486
85	74.5	H6RP085	9.0	30.8	0.256	2	3816	517
90	79.0	H6RP090	9.0	30.8	0.242	2	4021	551
95	83.5	H6RP095	9.0	33.4	0.257	3	4622	581
100	88.0	H6RP100	9.0	33.4	0.244	3	4835	616
105	92.5	H6RP105	9.0	37.0	0.267	3	5592	645
110	97.0	H6RP110	9.0	37.0	0.255	3	5820	681
115	101.5	H6RP115	9.0	38.5	0.257	3	7182	709
120	106.0	H6RP120	9.0	38.5	0.246	3	7529	746

OTM @ 5' = 82 ft-kips

8.5" - 9" Tip

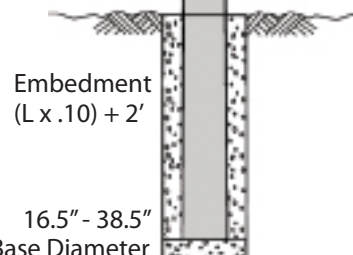



PRODUCT DATA

H 7 R P (13,120# / 8,200#)

TOTAL LENGTH (FT) "L"	TIP AGL (FT)	PART NUMBER	TIP DIAMETER (IN)	BASE DIAMETER (IN)	SLOPE (IN/FT)	NO. SECTIONS	WEIGHT (LB)	OVERTURNING MOMENT CAPACITY (FT-KIP)
40	34.0	H7RP040	10.0	20.0	0.250	1	1336	263
45	38.5	H7RP045	10.0	21.3	0.250	1	1558	299
50	43.0	H7RP050	10.0	22.5	0.250	1	1791	337
55	47.5	H7RP055	10.0	22.8	0.233	2	2565	373
60	52.0	H7RP060	10.0	24.0	0.233	2	2867	411
65	56.5	H7RP065	10.0	25.2	0.234	2	3180	446
70	61.0	H7RP070	10.0	26.4	0.234	2	3509	485
75	65.5	H7RP075	10.0	27.6	0.235	2	3816	521
80	70.0	H7RP080	10.0	28.8	0.235	2	4219	559
85	74.5	H7RP085	10.0	30.2	0.238	2	4643	595
90	79.0	H7RP090	10.0	31.2	0.236	2	5008	634
95	83.5	H7RP095	10.0	31.9	0.231	3	5899	668
100	88.0	H7RP100	10.0	33.1	0.231	3	6365	710
105	92.5	H7RP105	10.0	34.3	0.231	3	6853	742
110	97.0	H7RP110	10.0	35.5	0.232	3	7356	784
115	101.5	H7RP115	10.0	36.7	0.232	3	7853	816
120	106.0	H7RP120	10.0	37.9	0.233	3	8369	859

OTM @ 5' = 85 ft-kips

H 8 R P (15,040# / 9,400#)

TOTAL LENGTH (FT) "L"	TIP AGL (FT)	PART NUMBER	TIP DIAMETER (IN)	BASE DIAMETER (IN)	SLOPE (IN/FT)	NO. SECTIONS	WEIGHT (LB)	OVERTURNING MOMENT CAPACITY (FT-KIP)
40	34.0	H8RP040	10.0	19.2	0.230	1	1712	301
45	38.5	H8RP045	10.0	20.4	0.231	1	1993	343
50	43.0	H8RP050	10.0	21.5	0.230	1	2295	385
55	47.5	H8RP055	10.0	22.2	0.222	2	2645	428
60	52.0	H8RP060	10.0	23.3	0.222	2	2968	471
65	56.5	H8RP065	10.0	24.4	0.222	2	3366	512
70	61.0	H8RP070	10.0	25.6	0.223	2	3726	556
75	65.5	H8RP075	10.0	26.8	0.224	2	4161	597
80	70.0	H8RP080	10.0	27.9	0.224	2	4553	642
85	74.5	H8RP085	10.0	29.1	0.225	2	4961	682
90	79.0	H8RP090	10.0	30.2	0.224	2	5385	727
95	83.5	H8RP095	10.0	30.9	0.220	3	5925	766
100	88.0	H8RP100	10.0	32.0	0.220	3	6331	814
105	92.5	H8RP105	10.0	33.2	0.221	3	6917	851
110	97.0	H8RP110	10.0	34.3	0.221	3	7404	900
115	101.5	H8RP115	10.0	35.4	0.221	3	8040	935
120	106.0	H8RP120	10.0	36.6	0.222	3	8560	986

OTM @ 5' = 130 ft-kips

H 9 R P (16,800# / 10,500#)

TOTAL LENGTH (FT) "L"	TIP AGL (FT)	PART NUMBER	TIP DIAMETER (IN)	BASE DIAMETER (IN)	SLOPE (IN/FT)	NO. SECTIONS	WEIGHT (LB)	OVERTURNING MOMENT CAPACITY (FT-KIP)
40	34.0	H9RP040	10.0	20.0	0.250	1	1754	315
45	38.5	H9RP045	10.0	21.2	0.249	1	2050	383
50	43.0	H9RP050	10.0	22.5	0.250	1	2364	420
55	47.5	H9RP055	10.0	23.1	0.238	2	2740	478
60	52.0	H9RP060	10.0	24.3	0.238	2	3085	526
65	56.5	H9RP065	10.0	25.6	0.240	2	3477	572
70	61.0	H9RP070	10.0	26.8	0.240	2	3853	621
75	65.5	H9RP075	10.0	28.1	0.241	2	4314	667
80	70.0	H9RP080	10.0	29.3	0.241	2	4728	716
85	74.5	H9RP085	10.0	30.6	0.242	2	5175	761
90	79.0	H9RP090	10.0	31.8	0.242	2	5607	812
95	83.5	H9RP095	10.0	32.4	0.236	3	6153	856
100	88.0	H9RP100	10.0	33.7	0.237	3	6625	908
105	92.5	H9RP105	10.0	34.9	0.237	3	7240	950
110	97.0	H9RP110	10.0	36.2	0.238	3	7754	1004
115	101.5	H9RP115	10.0	37.4	0.238	3	8401	1045
120	106.0	H9RP120	10.0	38.7	0.239	3	8946	1100

OTM @ 5' = 133 ft-kips

10.0" Tip

Embedment (L x .10) + 2'

20.0" - 38.7" Base Diameter

PRODUCT DATA

H 1 0 R P (18,400# / 11,500#)

TOTAL LENGTH (FT) "L"	TIP AGL (FT)	PART NUMBER	TIP DIAMETER (IN)	BASE DIAMETER (IN)	SLOPE (IN/FT)	NO. SECTIONS	WEIGHT (LB)	OVERTURNING MOMENT CAPACITY (FT-KIP)
40	34.0	H10RP040	12.0	21.2	0.230	1	1945	368
45	38.5	H10RP045	12.0	22.4	0.231	1	2253	420
50	43.0	H10RP050	12.0	23.5	0.230	1	2581	472
55	47.5	H10RP055	12.0	25.1	0.238	2	3074	523
60	52.0	H10RP060	12.0	26.3	0.238	2	3440	576
65	56.5	H10RP065	12.0	27.6	0.240	2	3896	627
70	61.0	H10RP070	12.0	28.8	0.240	2	4304	680
75	65.5	H10RP075	12.0	30.1	0.241	2	4765	730
80	70.0	H10RP080	12.0	31.3	0.241	2	5210	785
85	74.5	H10RP085	12.0	32.6	0.242	2	5666	834
90	79.0	H10RP090	12.0	33.8	0.242	2	6148	890
95	83.5	H10RP095	12.0	34.4	0.236	3	6779	937
100	88.0	H10RP100	12.0	35.7	0.237	3	7282	995
105	92.5	H10RP105	12.0	36.9	0.237	3	7918	1041
110	97.0	H10RP110	12.0	38.2	0.238	3	8459	1100
115	101.5	H10RP115	12.0	39.4	0.238	3	9153	1141
120	106.0	H10RP120	12.0	40.7	0.239	3	9731	1206

OTM @ 5' = 183 ft-kips

12.0" Tip

Design Notes:

1. Pole designs are in accordance with ASCE 48, "Design of Steel Transmission Pole Structures".
2. Pole sections are ASTM grade 65 material with a charpy impact value of 15 ft-lbs at -20 F.
3. Multiple section poles include slip splice joints with a minimum slip length equal to 1.5 times the inside diameter across flats of the outer section at the splice.
4. Galvanized poles are hot-dip galvanized in accordance with ASTM A123.
5. Tabulated weights assume galvanized poles.

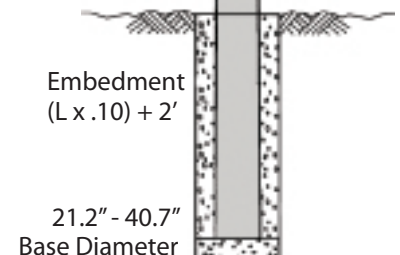

PARTS & ACCESSORIES

 <p>STEP BOLTS</p> <p>STEP BOLTS AND STEP BOLT CLIPS ARE OPTIONAL AND MUST BE SPECIFIED AT TIME OF ORDER.</p>	 <p>CLIMBING HARNESS TTFBH-4D JOURNEYMAN HARNESS</p> <p>TTFBH-C/P PROFESSIONAL HARNESS</p>	 <p>SAFETY CABLE SLIDER WITH CARABINEER TT-WG-500-W/SMC</p>	<p>SAFETY CABLE SYSTEM</p> <table border="0"> <thead> <tr> <th>Pole Height (AGL)</th> <th>Part Number</th> </tr> </thead> <tbody> <tr> <td>30' - 50'</td> <td>TT050TSP</td> </tr> <tr> <td>60' - 100'</td> <td>TT100TSP</td> </tr> <tr> <td>110' - 150'</td> <td>TT150TSP</td> </tr> </tbody> </table>	Pole Height (AGL)	Part Number	30' - 50'	TT050TSP	60' - 100'	TT100TSP	110' - 150'	TT150TSP
Pole Height (AGL)	Part Number										
30' - 50'	TT050TSP										
60' - 100'	TT100TSP										
110' - 150'	TT150TSP										



UTILITY STRUCTURES



GENERAL

ROHN has been a trusted name in quality engineered structures since 1948. Our extensive engineering capabilities include in-house structural and foundation design. We are able to design to both domestic and international standards. ROHN is one of the few tower designers and manufacturers able to provide drawings sealed by a Professional Engineer, to customers in 49 states as well as Washington DC and Puerto Rico. ROHN is able to fabricate even the most difficult projects with accuracy and reliability. ROHN can optimize pole designs based on individual customer requirements, manufacturing efficiencies and material availability. Our commitment to the Utility industry is to provide world class quality products with the shortest lead time.



CERTIFICATIONS

- CWB Certified Welding Fabricator
- AWS Certified Welding Fabricator, Inspectors and Educators
- Dual AISC Certified Steel Fabricator (Bridges & Highways)
- City of Los Angeles Certified Fabricator
- Clark County Certified Fabricator
- Multiple Vendor Certification

CAPABILITIES

- Heavy Duty Transmission & Distribution Poles
- Direct Embed & Base Plated Poles
- Lattice Structures
- Switches & Substation Steel
- Galvanized, Weathering Steel & Painted Finishes
- Tapered Slip Fit or Connection Flanged Poles

TRANSMISSION

ROHN fabricates transmission structures for projects ranging from light-duty in-line poles up to the largest diameter dead end structures. The structures are cut, formed, fabricated and galvanized on site at ROHN. ROHN can provide engineering, detailing and our AISC Certified fabrication facility can support large or small transmission projects across the globe.

DISTRIBUTION

ROHN provides structures to support electric power distribution in its many forms. ROHN offers both pre-engineered steel structures (wood pole equivalents) and larger distribution structures that can either be flanged at the base or direct embedded. ROHN also offers a wide selection of corrosion resistant coatings to guarantee the product life.

SUBSTATION STEEL

ROHN fabricates all forms of substation steel to allow the entire transmission and distribution build to be supplied by ROHN. We have hollow steel structures in stock to turn substation work around on time to keep pace with project schedules. ROHN can supply all cross arms, uprights, H-frames and any steel frame or support to complete the substation. Each substation item is hot-dip galvanized after fabrication for corrosion resistance.

SWITCHES

ROHN fabricates switch steel structures including all static masts, buss supports, arrestor structures, and all other steel components that make up the switch. The steel is fabricated by AWS and CWB welders in our AISC certified fabrication plant. From start to finish, we have your project covered.



TRANSPORTATION STRUCTURES



GENERAL

ROHN has been a trusted name in quality engineered structures since 1948. Our engineers study every aspect of a prospective job before designing a structure to fit your needs. We are able to design to both domestic and international standards. ROHN provides professional engineering certification for our designs. Our engineers are certified in 49 states as well as Washington DC and Puerto Rico. ROHN is able to fabricate the most difficult projects with accuracy and reliability. ROHN can optimize pole designs based on individual customer requirements, manufacturing efficiencies and material availability. Our commitment to the Transportation Industry is to provide world class quality products with the shortest lead time.



CERTIFICATIONS

- AISC Certified Steel Fabricator (Buildings & Simple Steel Bridges)
- AWS Certified Welders, Inspectors and Educators
- CWB Certified Welding Fabricator
- City of Los Angeles Certified Fabricator
- Clark County Certified Fabricator
- Multiple Vendor Certifications
- Manufactured to AASHTO Standards

CAPABILITIES

- Mast Arms
- Monotube Assemblies
- Steel Strain Poles
- High Past Poles
- Galvanized or Painted Finishes
- Weathering Steel
- Sign Structures

MAST ARMS

ROHN is considered the quality leader to state, county and municipal buyers of mast arm structures. ROHN mast arms are in service at intersections as wide as 88'. Our designs conform to all AASHTO standards as well as local design codes. ROHN's mast arms can be hot-dip galvanized and can also be painted upon request.

HIGH MAST POLES

For years, ROHN has been a reliable manufacturer of high mast lighting poles for state D.O.T. projects, prisons, port authorities and other commercial projects across the country. These organizations and many others choose ROHN because of our proven quality in manufacturing and design, as well as our focus on finding the best possible value for our customers.

High mast lighting poles range in height from 60' to 150' and are designed to accommodate a number of lowering device manufacturers' equipment. High mast poles can be galvanized or painted based on customer requirements.

MONOTUBE ASSEMBLIES

In applications where a very long span is needed and a more decorative appearance is needed, some State Departments of Transportation will specify monotube assemblies for Tubular Signal Structures and Sign Bridge Applications.

All ROHN monotube assemblies are designed to AASHTO standards and comply with appropriate state specifications. These monotube assemblies can range from 20' to 200' and are designed to accommodate a number of various highway signs and signals. Monotube assemblies can be galvanized or painted based on customer requirements.

SIGN STRUCTURES

ROHN Products, LLC has the experience and expertise to address all of your metal fabrication needs. Through 60 years, ROHN has expanded into fabricated Sign Structures and now has the capabilities to design and build Steel Overhead Sign Trusses, Cantilever Structures, Butterfly Structures, and DMS Sign Structures. ROHN Products, LLC is certified by the American Institute of Steel Construction for both Steel Building Structures and Simple Steel Bridges. Our welders are qualified in accordance with the American Welding Society and various State DOT Requirements.

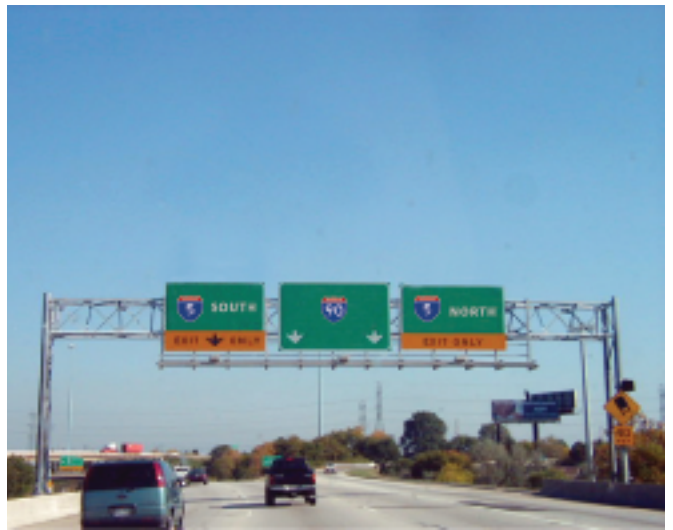

WIND TURBINE STRUCTURES



GENERAL

ROHN provides an extensive analysis on Wind Turbine structures that includes examination of extreme wind, extreme ice, yawing, fatigue, vibration and more. The dynamic nature of a wind turbine requires an additional investment in the analysis of the support structure to ensure the structures perform safely and efficiently.

CERTIFICATIONS

- AISC Certified Steel Fabricator (Buildings & Simple Steel Bridges)
- AWS Certified Welders, Inspectors and Educators
- CWB Certified Welding Fabricator
- City of Los Angeles Certified Fabricator
- Clark County Certified Fabricator
- Multiple Vendor Certifications

CAPABILITIES

- Pole, Self-Supporting Latticed and Guyed Mast Designs
- Fatigue Analysis
- Natural Frequency Analysis
- Preparation of Loading Documents
- Braking, Short Circuit, Shutdown Analysis
- Special Design Requests Considered



SELF-SUPPORTING TOWERS

ROHN Self-Supporting Towers provide an efficient design specific for each turbine's loading criteria. The towers are designed with tubular or solid legs and angle braces. The tower top flange is designed with a transition plate to receive the turbine base. ROHN lightweight towers have been designed with hinged bases to allow the tower to be slowly lowered for turbine maintenance and repairs.

POLES

ROHN designs both tapered slip joint poles and flanged poles to support Wind Turbines. ROHN turbine support poles have ranged from 30' in height to 140' in height supporting turbines up to 50 kW.



NOTES

TELESCOPING MASTS





TELESCOPING MASTS FOR USE IN GUYED OR BRACKETED INSTALLATIONS

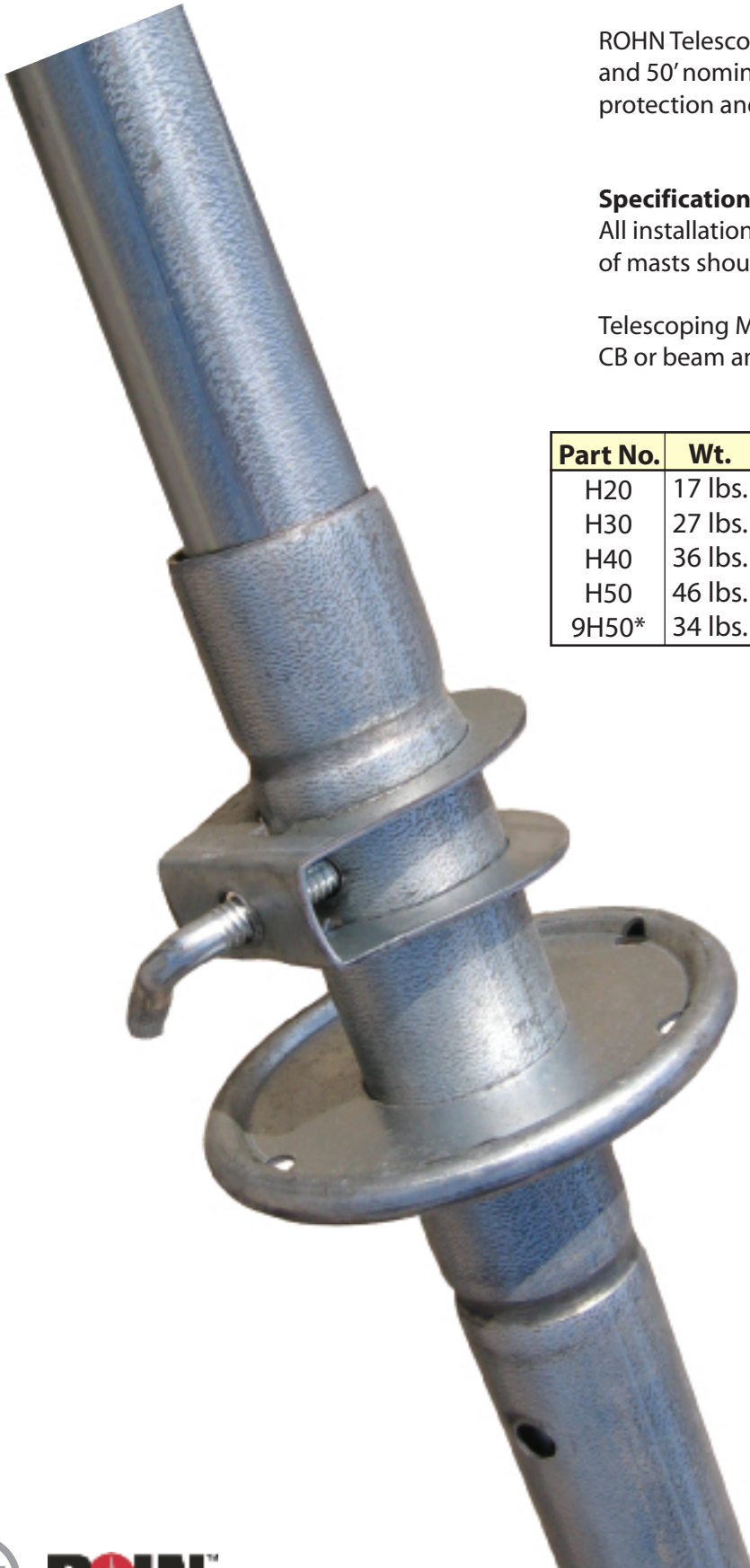

ROHN Telescoping Masts are available in 20', 30', 33', 40' and 50' nominal heights. All are pre-galvanized for corrosion protection and come assembled with hardware.

Specifications:

All installations must be guyed or bracketed. Installation of masts should be done by experienced professionals.

Telescoping Masts are not recommended for commercial, CB or beam antenna installations.

Part No.	Wt.	O.D. Bottom	O.D. Top	Shipping Length
H20	17 lbs.	1 1/2"	1 1/4"	123"
H30	27 lbs.	1 3/4"	1 1/4"	123"
H40	36 lbs.	2"	1 1/4"	123"
H50	46 lbs.	2 1/4"	1 1/4"	123"
9H50*	34 lbs.	2 1/4"	1 1/4"	99"

*9H50 is UPS shippable.

Note:

Guys, guy hardware, anchors and base mount must be ordered separately. Refer to pages 245-248 for standard kits and page 249 for individual components.



TELESCOPING MASTS
 H20 | H30 | H40 | H50 | 9H50

NEW PRODUCT
9H50
 UPS Shippable!

Top rings are adjustable based on antenna mounting.

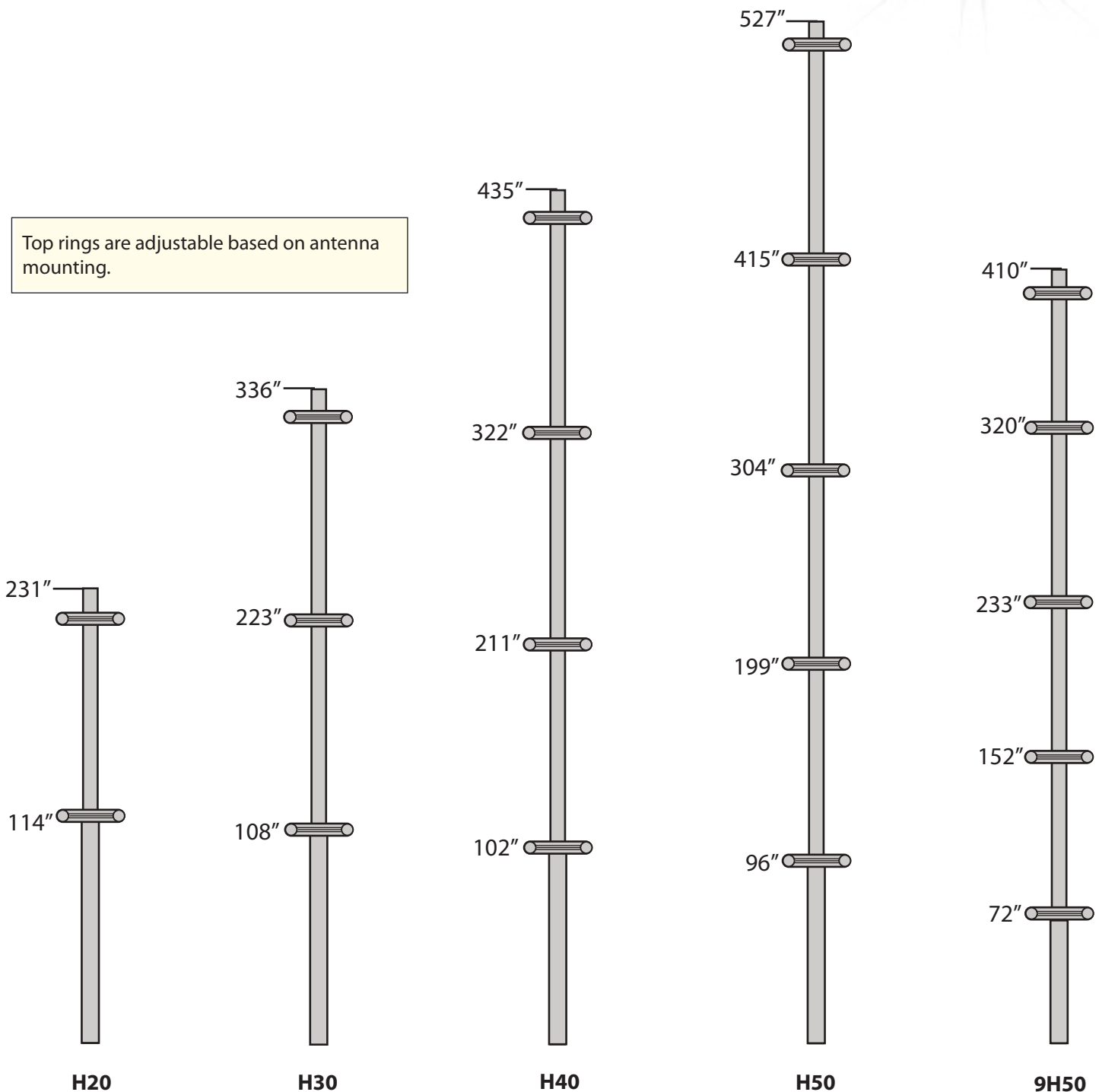



INSTALLATION GUIDELINES

All Telescoping Mast kits include guys, connection hardware, anchors and ground mount.
Mast must be ordered separately.

H20 GUY KIT

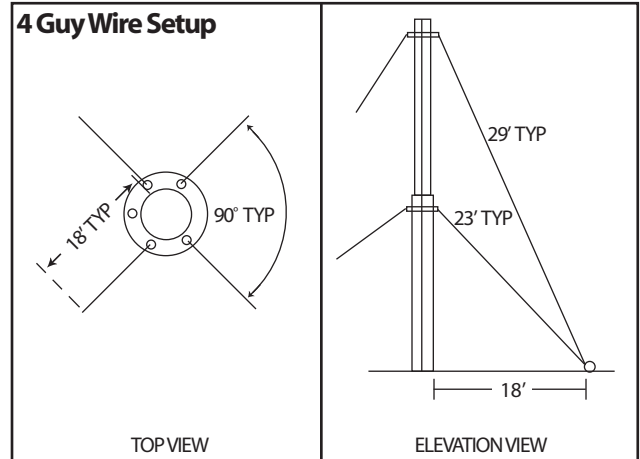
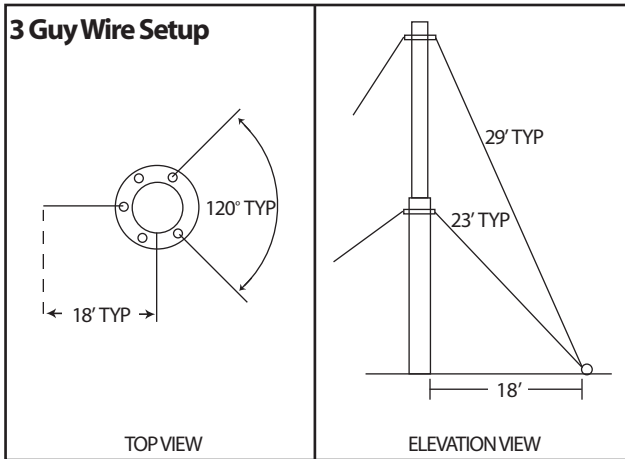

H203WAYGUY

Actual Wire Required - 200'

1	618	1000' - 6 Strand/18 GA Wire
3	GAS4303	1/2" x 30" Screw Anchor
12	61820GRPL	618/620 Gripple
1	GTMBL	Ground Mount

H204WAYGUY

Actual Wire Required - 250'

1	618	1000' - 6 Strand/18 GA Wire
4	GAS4303	1/2" x 30" Screw Anchor
16	61820GRPL	618/620 Gripple
1	GTMBL	Ground Mount

H30 GUY KIT

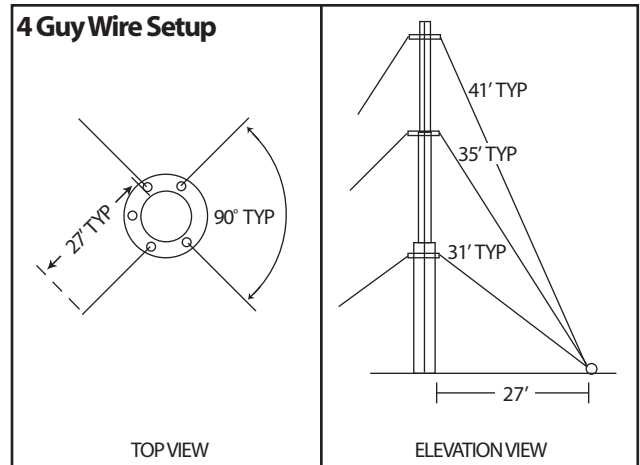
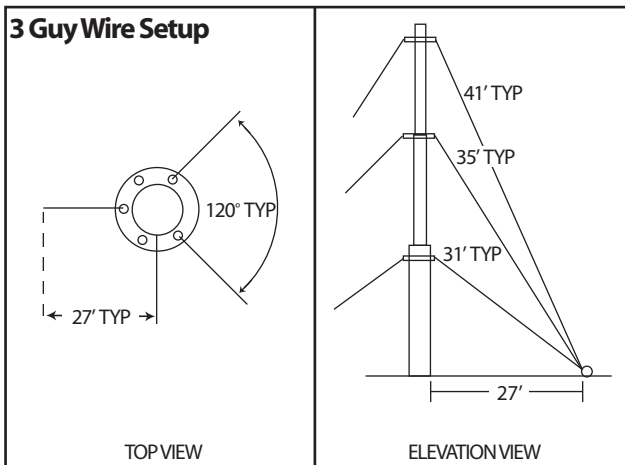

H303WAYGUY

Actual Wire Required - 350'

1	618	1000' - 6 Strand/18 GA Wire
3	GAS4303	1/2" x 30" Screw Anchor
18	61820GRPL	618/620 Gripple
1	GTMBL	Ground Mount

H304WAYGUY

Actual Wire Required - 450'

1	618	1000' - 6 Strand/18 GA Wire
4	GAS4303	1/2" x 30" Screw Anchor
24	61820GRPL	618/620 Gripple
1	GTMBL	Ground Mount

INSTALLATION GUIDELINES

All Telescoping Mast kits include guys, connection hardware, anchors and ground mount.
Mast must be ordered separately.

H40 GUY KIT

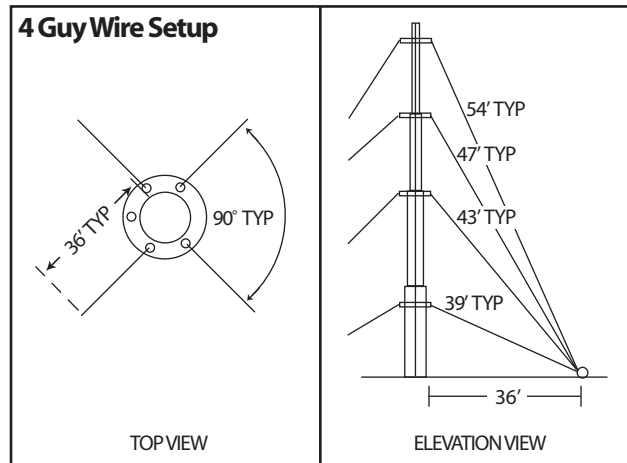
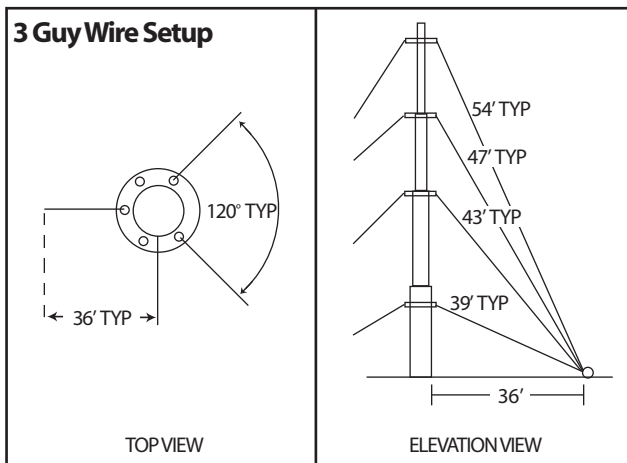

H403WAYGUY

H404WAYGUY

Actual Wire Required - 550'

1	618	1000' - 6 Strand/18 GA Wire
3	GAS4303	1/2" x 30" Screw Anchor
24	61820GRPL	618/620 Gripple
1	GTMBL	Ground Mount

Actual Wire Required - 750'

1	618	1000' - 6 Strand/18 GA Wire
4	GAS4303	1/2" x 30" Screw Anchor
32	61820GRPL	618/620 Gripple
1	GTMBL	Ground Mount

H50 GUY KIT

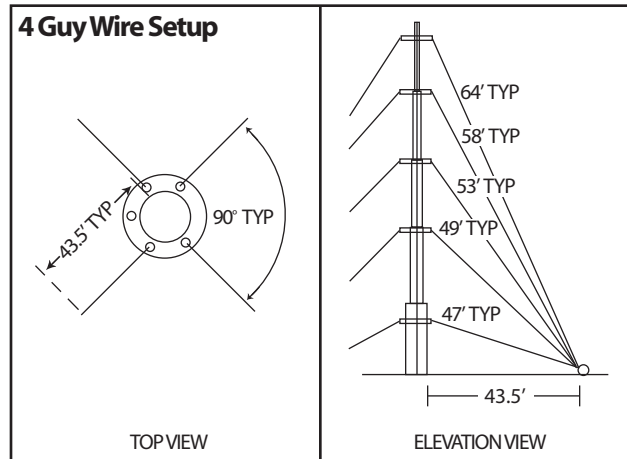
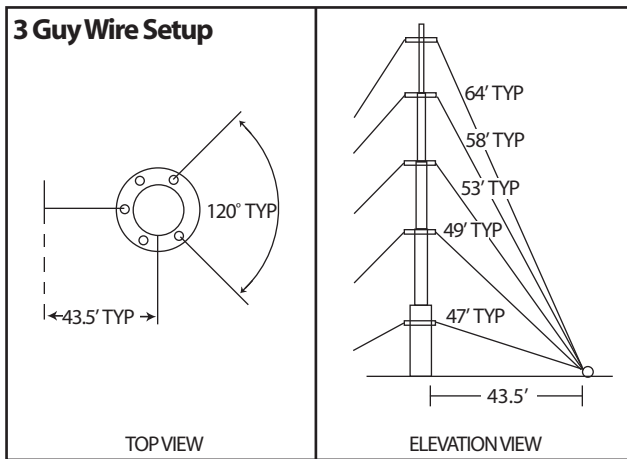

H503WAYGUY

H504WAYGUY

Actual Wire Required - 850'

1	618	1000' - 6 Strand/18 GA Wire
3	GAS604	5/8" x 48" Screw Anchor
30	61820GRPL	618/620 Gripple
1	GTMBL	Ground Mount

Actual Wire Required - 1100'

2	618	1000' - 6 Strand/18 GA Wire
4	GAS604	5/8" x 48" Screw Anchor
40	61820GRPL	618/620 Gripple
1	GTMBL	Ground Mount



INSTALLATION GUIDELINES

All Telescoping Mast kits include guys, connection hardware, anchors and ground mount.
Mast must be ordered separately.

9H50 GUY KIT

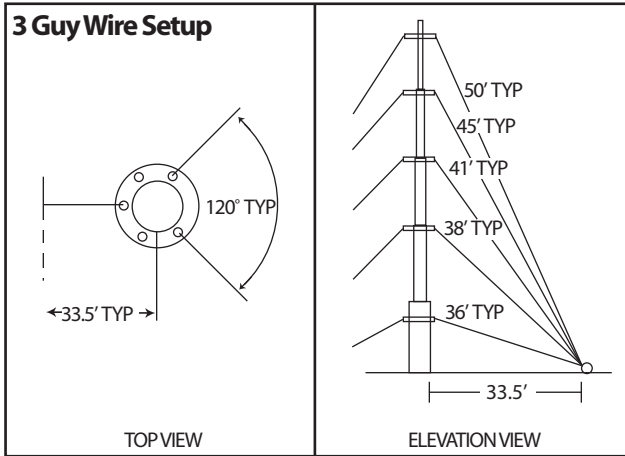

9H503WAYGUY

Actual Wire Required - 650'

1	618	1000' - 6 Strand/18 GA Wire
3	GAS604	5/8" x 48" Screw Anchor
30	61820GRPL	618/620 Gripple
1	GTMBL	Ground Mount

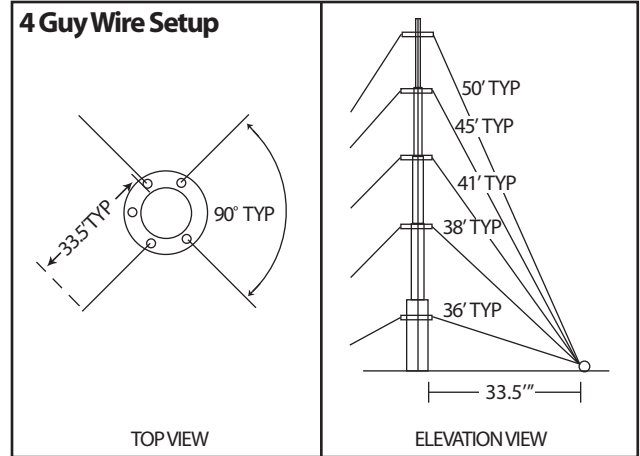

9H504WAYGUY

Actual Wire Required - 850'

1	618	1000' - 6 Strand/18 GA Wire
4	GAS604	5/8" x 48" Screw Anchor
40	61820GRPL	618/620 Gripple
1	GTMBL	Ground Mount

INSTALLATION GUIDELINES

1. Installation or dismantling of telescoping masts require professional contractors experienced with guyed masts.
2. All installations must be bracketed or guyed.
3. The pictured guy layouts are for a typical installation. Individual installation requirements may vary.
4. Antenna load (top load) should not exceed an effective projected area (EPA) of 2 square feet (see your antenna specifications).

PARTS & ACCESSORIES

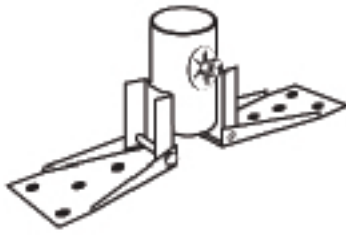
**UNIVERSAL RIDGE MOUNT**

Completely assembled for quick and easy flat or peaked roof installation. Allows tall masts to be swung up along the ridge of a roof.

Part No.	Description
UM20	Holds masts to 1 1/2" O.D.
UM30	Holds masts to 1 3/4" O.D.
UM40	Holds masts to 2" O.D.
UM50	Holds masts to 2 1/4" O.D.

Roof mounting hardware not included.

**GROUND MOUNT**

Sturdy, galvanized, drive-in type mount for all ROHN telescoping masts, 1 1/4" tubing and 1 1/2" tubing.

Part No.	Description
GTMBL	Ground Mount

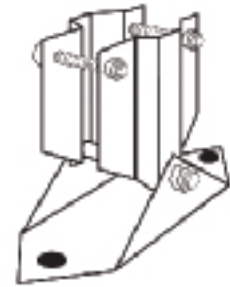
**UNIVERSAL ROOF MOUNT**

Features galvanized finish and heavy duty steel throughout. Completely assembled. Holds all ROHN telescoping masts, 1 1/4" tubing and 1 1/2" tubing.

Part No.	Description
ETMB	Universal Mount

Roof mounting hardware not included.

**GALVANIZED GUYS**

Non-tangling interconnected coils. Packaged 1000' per box.

Part No.	Description
618	6 strand, 18 GA

**SCREW ANCHORS**

Hot-dip galvanized screw anchor.

Part No.	Description
GAS4303	1/2" dia. x 30" long with 4" auger
GAS604	5/8" dia. x 48" long with 6" auger

**GUY CONNECTIONS**

Use for easy installation of 6 strand, 18 GA guys.

Part No.	Description
61820GRPL	Gripple Grip

Not to be used to suspend or lift personnel.

Refer to page 251 for roof mounts. Refer to page 275 for wall mounts.

ROOF MOUNTS



EFFECTIVE WIND VELOCITY FORMULA SHEET

ROHN recommends a minimum 75 mph Effective Wind Velocity be used for determining ballast requirements. Refer to page 270 for ballast requirements and general notes.

$V_e = (C1) (C2) (V)$
V_e = Effective Wind Velocity at centerline of antenna for calculating required ballast. C1 = Importance factor coefficient from Table 1. C2 = Combined exposure and gust effect factor coefficient from Table 2. V = Design ground wind speed for location, per ANSI/TIA-222-G.

Table 1: Values of C1		Roof Height	
Class	Description for installing considering height, use or location	≤ 60 ft.	> 60 ft.
I	Low hazard to human life and/or damage to property, optional services provided.	1.29	0.93
II	Significant hazard to human life and/or damage to property, services available by other means.	1.38	1.00
III	Substantial hazard to human life and/or damage to property, essential services provided.	1.48	1.07

Exposure	Description of Surrounding Terrain
B	Urban and suburban areas, wooded areas, or other terrain with numerous closely spaced obstructions having the size of single-family dwellings or larger.
C	Open terrain with scattered obstructions having heights generally less than 30' [9.1m], including flat, open country and grasslands.
D	Flat, unobstructed shorelines exposed to wind flowing over open water, smooth mud flats, salt flats, and other similar terrain.

Table 2: Values of C2			
Antenna Centerline Elevation Above Ground Level (ft.)	Exposure		
	B	C	D
	Urban or Wooded Areas	Open Country & Grasslands	Open Water or Smooth Terrain
0-15	0.82	0.90	0.99
20	0.82	0.92	1.01
25	0.82	0.95	1.04
30	0.82	0.96	1.05
40	0.85	0.99	1.08
50	0.88	1.02	1.10
60	0.90	1.04	1.12
70	0.92	1.05	1.13
80	0.94	1.07	1.14
90	0.95	1.09	1.16
100	0.97	1.10	1.17
120	0.99	1.12	1.19
140	1.02	1.14	1.20
160	1.04	1.15	1.21
180	1.05	1.17	1.23
200	1.07	1.18	1.24
250	1.10	1.21	1.26
300	1.13	1.23	1.28
350	1.16	1.25	1.30
400	1.18	1.27	1.31
450	1.20	1.29	1.33
500	1.22	1.30	1.34

Example: 30' antenna elevation, 90 mph design ground wind speed, Class I, Exposure B
 $V_e = (1.29) (0.82) (90) = 95 \text{ mph}$
 The minimum Effective Wind Velocity for determining ballast requirements for this example would be 95 mph.

This data sheet is provided to assist consumers in determining the minimum Effective Wind Velocity to be used for determining ballast requirements from a ROHN Non-Penetrating Roof Mount Ballast Chart. Higher velocities may be required for sites located on hills, escarpments or ridges (refer to ANSI/TIA-222-G). Potential increases in wind velocity due to channeling, roof projections and other obstructions must also be considered. The information shown should not be relied upon without competent professional examination and verification of its accuracy and suitability for a specific site or application.

FRM NON-PENETRATING

The FRM mount is a lightweight mount and is galvanized for corrosion protection. The FRM mount is easily shipped via UPS.

Order (1) optional FRMMAT (1/8" thick) or (1) optional FRMPAD (3/8" thick) for a protective barrier between the mount and the roof. Order (1) optional SCK150 safety cable kit (3/16" x 150').

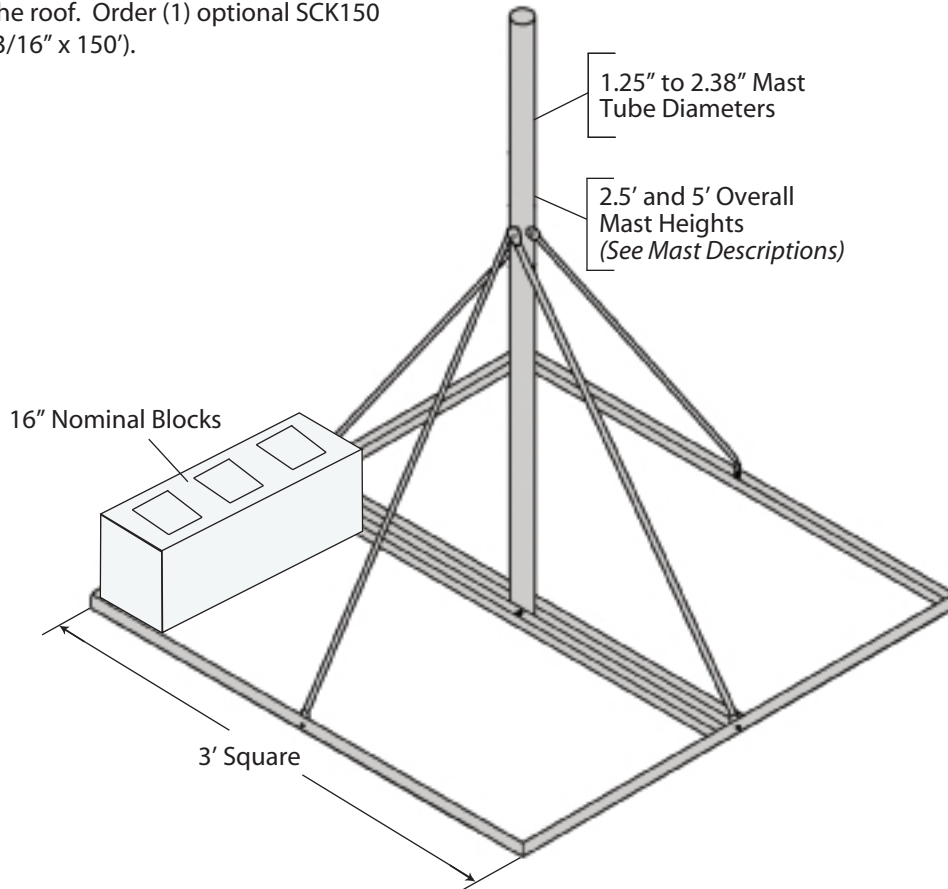

MAST SPECIFICATIONS

Mount Part No.	Mast Part No.	Mast Description & Height
FRM125	FY202	1.25" O.D. x 16 GA. x 5.0' (PG)
FRM150	FY203	1.50" O.D. x 16 GA. x 2.5' (PG)
FRM166	FY204	1.66" O.D. x 16 GA. x 2.5' (PG)
FRM238	FY205	2.38" O.D. x 0.154" wall x 2.5' (HDG)
FRM225	FY205SP	2.25" O.D. x 14 GA. x 5.0' (HDG)
FRM238SP5	FY253	2.38" O.D. x 0.154" wall x 5.0' (HDG)

PG = Pre-galvanized mast
HDG = Hot-dip galvanized mast

FRM BALLAST REQUIREMENTS

Effective Projected Area (EPA) (FT ²)	Ballast (LBS)	Zero Velocity Load (PSF)	Vs (MPH)	Vmax at centroid of projected area, (MPH)			
				h=2 FT	h=3 FT	h=4 FT	h=5 FT
2	100	12	140	135	110	96	85
	200	24	198	188	153	133	119
	300	36	242	222	182	157 (154)	141 (131)
	400	48	280	269	219 (197)	190 (154)	170 (131)
4	100	12	99	96	78	68	60
	200	24	140	133	108	94	84
	300	36	171	157	129	111	99 (93)
	400	48	198	190	155 (139)	134(109)	120 (93)
6	100	12	81	78	64	55	49
	200	24	114	108	88	77	68
	300	36	140	128	105	91 (89)	81 (76)
	400	48	161	155	127 (114)	110 (89)	98 (76)

h = Distance from support surface to centroid of EPA.

Vs = Effective wind velocity resulting in sliding on a flat surface with a .50 coefficient of friction.

Vmax = Effective wind velocity based on strength or overturning.

NOTE: The velocities in () apply to the FRM125 mount when the strength of the FRM125 mast governs.

JRM NON-PENETRATING

The JRM ships broken down on one skid and weighs approximately 50 lbs. when assembled. The JRM is galvanized for corrosion protection. The JRM is used in cellular, PCS, broadband and other applications.

Order (1) optional JRMMAT (1/8" thick) or (1) optional JRMPAD (3/8" thick) for a protective barrier between the mount and the roof. Order (1) optional SCK150 safety cable kit (3/16" x 150').

Refer to pages 255-256 for ballast requirements.

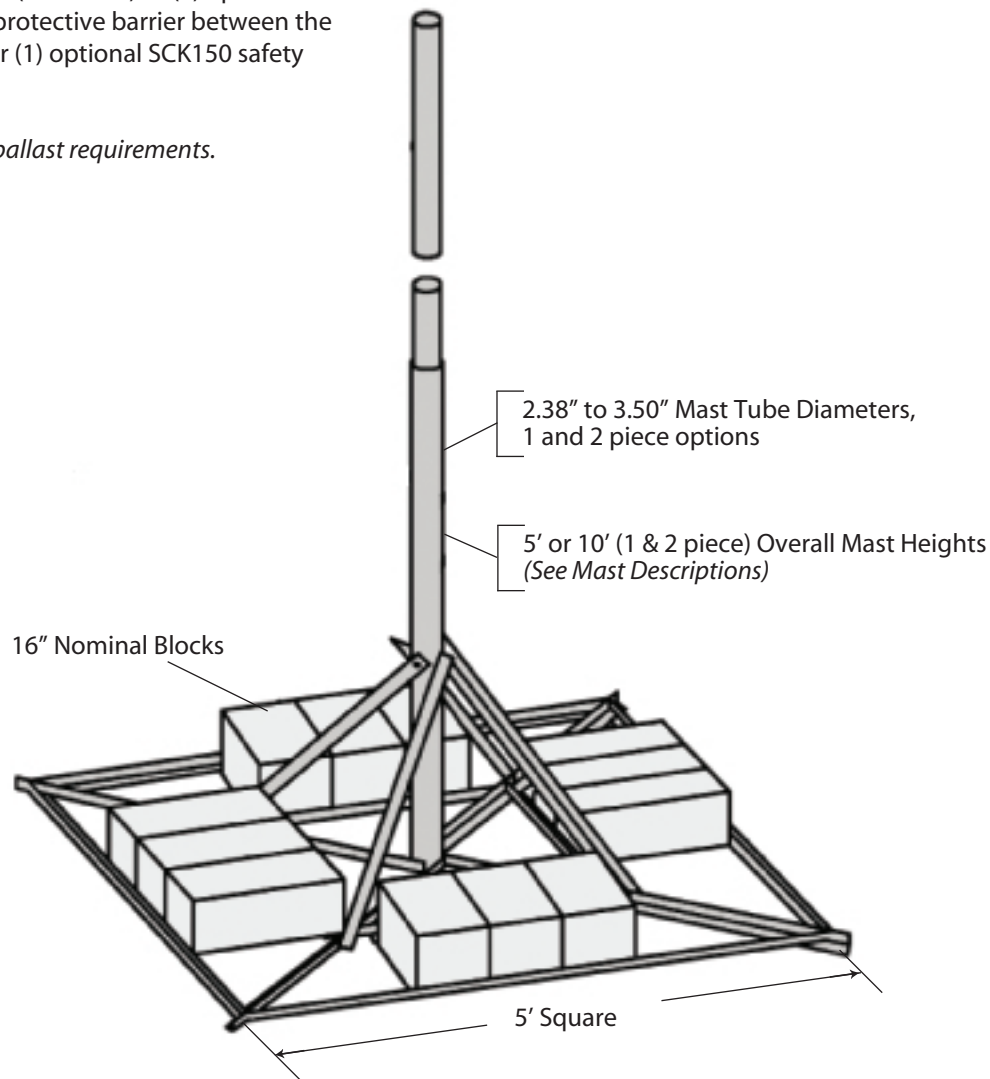

MAST SPECIFICATIONS

Mount Part No.	Mast Part No.	Mast Description & Height
JRM23805	FZ1755	2.38" O.D. x 0.154" wall x 5.0' (HDG) (1 piece)
JRM23855	FZ1753 / FZ1754	2.38" O.D. x 0.154" wall x 10.0' (HDG) (2 pieces)
JRM23810	FZ1756	2.38" O.D. x 0.154" wall x 10.0' (HDG) (1 piece)
JRM27505	FZ1757	2.88" O.D. x 0.203" wall x 5.0' (HDG) (1 piece)
JRM27555	FZ1758 / FZ1759	2.88" O.D. x 0.203" wall x 10.0' (HDG) (2 pieces)
JRM27510	FZ1760	2.88" O.D. x 0.203" wall x 10.0' (HDG) (1 piece)
JRM35010	FZ1761	3.50" O.D. x 0.216" wall x 10.0' (HDG) (1 piece)

HDG = Hot-dip galvanized mast

JRM BALLAST REQUIREMENTS

Effective Projected Area (EPA) (FT ²)	Ballast (LBS)	Zero Velocity Load (PSF)	Vs (MPH)	Vmax at centroid of projected area, (MPH)							
				h=2 FT	h=3 FT	h=4 FT	h=5 FT	h=6 FT	h=7 FT	h=8 FT	h=9 FT
4	250	10.0	110	129	105	91	82	75	69	65	61
	350	14.0	131	153	125	108	97	88	82	76	72
	450	18.0	148	173	141	122	110	100	93	87	82
	550	22.0	164	191	156	135	121	111	102	96	90
	650	26.0	178	208	170	147	132	120	111	104	98
	750	30.0	191	224	183	158	141	129	120	112	105
	850	34.0	204	238	194	168	151	137	127	119	112
	950	38.0	215	252	205	178	159	145	135	126	119
	1050	42.0	226	265	216	187	167	153	141	132	125
	1150	46.0	237	277	226	196	175	160	148	138	131
	1250	50.0	247	289	236	204	183	167	154	144	136
5	250	10.0	99	115	94	82	73	67	62	58	54
	350	14.0	117	137	112	97	86	79	73	68	64
	450	18.0	133	155	126	110	98	89	83	77	73
	550	22.0	147	171	140	121	108	99	92	86	81
	650	26.0	159	186	152	132	118	107	100	93	88
	750	30.0	171	200	163	141	126	115	107	100	94
	850	34.0	182	213	174	151	135	123	114	106	100
	950	38.0	193	225	184	159	142	130	120	113	106
	1050	42.0	203	237	193	167	150	137	126	118	112
	1150	46.0	212	248	202	175	157	143	132	124	117
	1250	50.0	221	258	211	183	163	149	138	129	122
6	250	10.0	90	105	86	75	67	61	56	53	50
	350	14.0	107	125	102	88	79	72	67	62	59
	450	18.0	121	141	115	100	89	82	76	71	67
	550	22.0	134	156	128	111	99	90	84	78	74
	650	26.0	145	170	139	120	107	98	91	85	80
	750	30.0	156	183	149	129	115	105	98	91	86
	850	34.0	166	194	159	137	123	112	104	97	92
	950	38.0	176	205	168	145	130	119	110	103	97
	1050	42.0	185	216	176	153	137	125	115	108	102
	1150	46.0	193	226	185	160	143	131	121	113	107
	1250	50.0	202	236	192	167	149	136	126	118	111
7	250	10.0	84	98	80	69	62	56	52	49	46
	350	14.0	99	115	94	82	73	67	62	58	54
	450	18.0	112	131	107	93	83	76	70	65	62
	550	22.0	124	145	118	102	92	84	77	72	68
	650	26.0	135	157	128	111	100	91	84	79	74
	750	30.0	145	169	138	120	107	98	90	85	80
	850	34.0	154	180	147	127	114	104	96	90	85
	950	38.0	163	190	155	135	120	110	102	95	90
	1050	42.0	171	200	163	141	126	115	107	100	94
	1150	46.0	179	209	171	148	132	121	112	105	99
	1250	50.0	187	218	178	154	138	126	117	109	103
8	250	10.0	78	91	75	65	58	53	49	46	43
	350	14.0	92	108	88	76	68	62	58	54	51
	450	18.0	105	122	100	87	77	71	65	61	58
	550	22.0	116	135	111	96	86	78	72	68	64
	650	26.0	126	147	120	104	93	85	79	74	69
	750	30.0	135	158	129	112	100	91	85	79	75
	850	34.0	144	168	137	119	106	97	90	84	79
	950	38.0	152	178	145	126	113	103	95	89	84
	1050	42.0	160	187	153	132	118	108	100	94	88
	1150	46.0	168	196	160	138	124	113	105	98	92
	1250	50.0	175	204	167	144	129	118	109	102	96
10	250	10.0	70	82	67	58	52	47	44	41	38
	350	14.0	83	97	79	68	61	56	52	48	46
	450	18.0	94	110	89	77	69	63	59	55	52
	550	22.0	104	121	99	86	77	70	65	61	57
	650	26.0	113	132	107	93	83	76	70	66	62
	750	30.0	121	141	115	100	89	82	76	71	67
	850	34.0	129	151	123	106	95	87	80	75	71
	950	38.0	136	159	130	113	101	92	85	80	75
	1050	42.0	143	167	137	118	106	97	89	84	79
	1150	46.0	150	175	143	124	111	101	94	88	83
	1250	50.0	156	183	149	129	115	105	98	91	86

h = Distance from support surface to centroid of EPA.

Vmax = Effective wind velocity based on strength or overturning.

Vs = Effective wind velocity resulting in sliding on a flat surface with a .50 coefficient of friction.

NOTE: Mast strength may govern antenna capacity.



JRM BALLAST REQUIREMENTS

Effective Projected Area (EPA) (FT ²)	Ballast (LBS)	Zero Velocity Load (PSF)	Vs (MPH)	Vmax at centroid of projected area, (MPH)							
				h=2 FT	h=3 FT	h=4 FT	h=5 FT	h=6 FT	h=7 FT	h=8 FT	h=9 FT
12	250	10.0	64	75	61	53	47	43	40	37	35
	350	14.0	75	88	72	62	56	51	47	44	42
	450	18.0	86	100	82	71	63	58	53	50	47
	550	22.0	95	111	90	78	70	64	59	55	52
	650	26.0	103	120	98	85	76	69	64	60	57
	750	30.0	110	129	105	91	82	75	69	65	61
	850	34.0	118	137	112	97	87	79	73	69	65
	950	38.0	124	145	119	103	92	84	78	73	68
	1050	42.0	131	153	125	108	97	88	82	76	72
	1150	46.0	137	160	131	113	101	92	85	80	75
1250	50.0	143	167	136	118	105	96	89	83	79	
14	250	10.0	59	69	56	49	44	40	37	35	33
	350	14.0	70	82	67	58	52	47	44	41	38
	450	18.0	79	93	76	65	59	53	49	46	44
	550	22.0	88	102	84	72	65	59	55	51	48
	650	26.0	95	111	91	79	70	64	59	56	52
	750	30.0	102	120	98	85	76	69	64	60	56
	850	34.0	109	127	104	90	80	73	68	64	60
	950	38.0	115	135	110	95	85	78	72	67	63
	1050	42.0	121	141	115	100	89	82	76	71	67
	1150	46.0	127	148	121	105	94	85	79	74	70
1250	50.0	132	154	126	109	98	89	82	77	73	
16	250	10.0	55	65	53	46	41	37	35	32	30
	350	14.0	65	76	62	54	48	44	41	38	36
	450	18.0	74	87	71	61	55	50	46	43	41
	550	22.0	82	96	78	68	61	55	51	48	45
	650	26.0	89	104	85	74	66	60	56	52	49
	750	30.0	96	112	91	79	71	65	60	56	53
	850	34.0	102	119	97	84	75	69	64	60	56
	950	38.0	108	126	103	89	80	73	67	63	59
	1050	42.0	113	132	108	94	84	76	71	66	62
	1150	46.0	118	138	113	98	88	80	74	69	65
1250	50.0	124	144	118	102	91	83	77	72	68	
18	250	10.0	52	61	50	43	38	35	33	30	29
	350	14.0	62	72	59	51	46	42	38	36	34
	450	18.0	70	82	67	58	52	47	44	41	38
	550	22.0	77	90	74	64	57	52	48	45	43
	650	26.0	84	98	80	69	62	57	52	49	46
	750	30.0	90	105	86	75	67	61	56	53	50
	850	34.0	96	112	92	79	71	65	60	56	53
	950	38.0	102	119	97	84	75	68	63	59	56
	1050	42.0	107	125	102	88	79	72	67	62	59
	1150	46.0	112	131	107	92	83	75	70	65	62
1250	50.0	116	136	111	96	86	79	73	68	64	
20	250	10.0	49	58	47	41	37	33	31	29	27
	350	14.0	58	68	56	48	43	39	37	34	32
	450	18.0	66	77	63	55	49	45	41	39	37
	550	22.0	73	86	70	61	54	49	46	43	40
	650	26.0	80	93	76	66	59	54	50	47	44
	750	30.0	86	100	82	71	63	58	53	50	47
	850	34.0	91	106	87	75	67	61	57	53	50
	950	38.0	96	113	92	80	71	65	60	56	53
	1050	42.0	101	118	97	84	75	68	63	59	56
	1150	46.0	106	124	101	88	78	71	66	62	58
1250	50.0	110	129	105	91	82	75	69	65	61	
22	250	10.0	47	55	45	39	35	32	29	28	26
	350	14.0	56	65	53	46	41	38	35	33	31
	450	18.0	63	74	60	52	47	43	39	37	35
	550	22.0	70	82	67	58	52	47	44	41	38
	650	26.0	76	89	72	63	56	51	47	44	42
	750	30.0	82	95	78	67	60	55	51	48	45
	850	34.0	87	102	83	72	64	59	54	51	48
	950	38.0	92	107	88	76	68	62	57	54	51
	1050	42.0	97	113	92	80	71	65	60	56	53
	1150	46.0	101	118	96	83	75	68	63	59	56
1250	50.0	105	123	101	87	78	71	66	62	58	

h = Distance from support surface to centroid of EPA.

Vmax = Effective wind velocity based on strength or overturning.

Vs = Effective wind velocity resulting in sliding on a flat surface with a .50 coefficient of friction.

NOTE: Mast strength may govern antenna capacity.

BRM4 NON-PENETRATING

The BRM4 mount is hot-dip galvanized after fabrication for corrosion protection.

Order (1) optional BRM4MAT (1/8" thick) or (1) optional BRM4PAD (3/8" thick) for a protective barrier between the mount and the roof. Order (1) optional SCK150 safety cable kit (3/16" x 150').

Refer to pages 258-259 for ballast requirements.

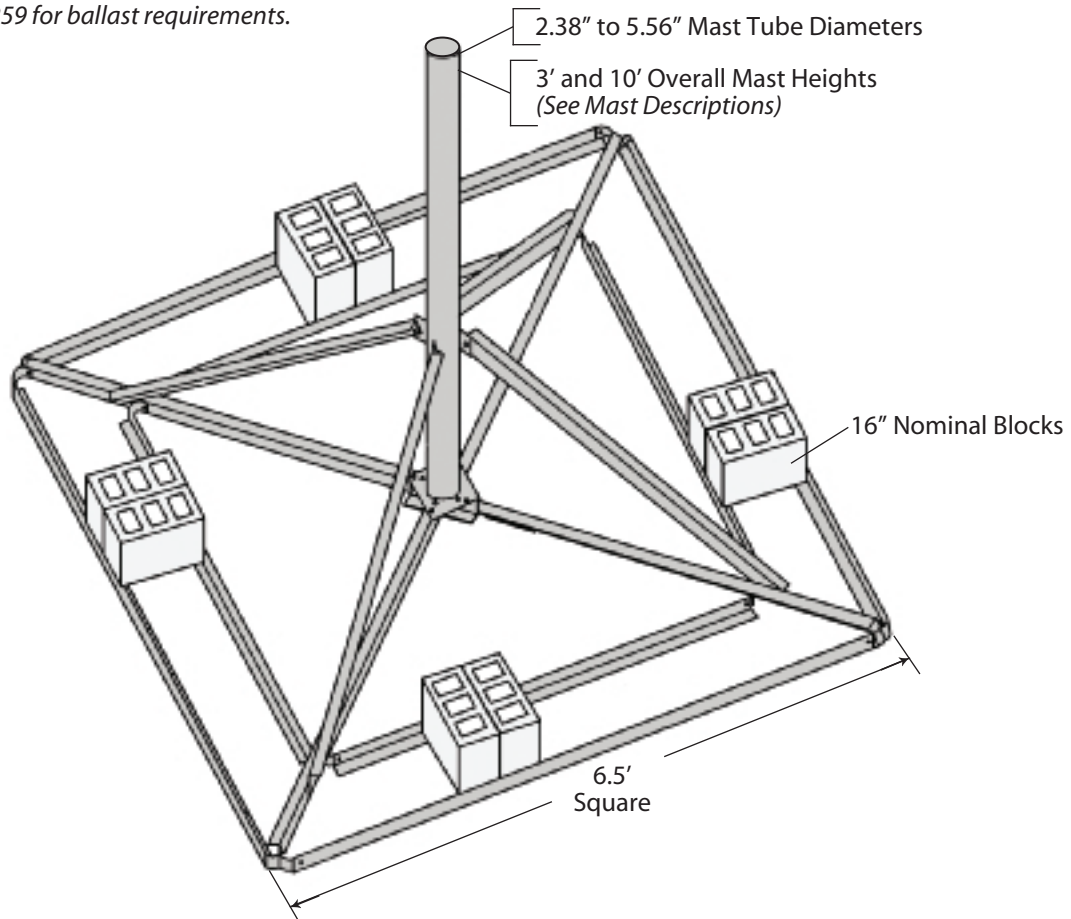

MAST SPECIFICATIONS

Mount Part No.	Mast Part No.	Mast Description & Height
BRM425	KY1590	2.38" O.D. x 0.154" wall x 3.0'
BRM430	KY1592	2.88" O.D. x 0.203" wall x 3.0'
BRM435	KY1594	3.50" O.D. x 0.216" wall x 3.0'
BRM440	KY1596	4.00" O.D. x 0.226" wall x 3.0'
BRM445	KY1598	4.50" O.D. x 0.237" wall x 3.0'
BRM455	KY1600	5.56" O.D. x 0.258" wall x 3.0'
BRM42510	KY2061	2.38" O.D. x 0.154" wall x 10.0'
BRM43510	KY2063	3.50" O.D. x 0.216" wall x 10.0'
BRM44510	KY2065	4.50" O.D. x 0.237" wall x 10.0'

BRM4
BALLAST REQUIREMENTS

Effective Projected Area (EPA) (FT ²)	Ballast (LBS)	Zero Velocity Load (PSF)	Vs (MPH)	Vmax at centroid of projected area, (MPH)							
				h=2 FT	h=3 FT	h=4 FT	h=5 FT	h=6 FT	h=7 FT	h=8 FT	h=9 FT
2	300	7.1	171	242	198	171	153	140	130	121	114
	500	11.8	221	313	256	221	198	181	167	157	148
	700	16.6	261	370	302	262	234	214	198	185	175
	900	21.3	296	416	340	294	263	240	223	208	196
	1100	26.0	328	448	366	317	284	259	240	224	211
	1300	30.8	356	478	391	338	302	276	256	239	225
	1500	35.5	383	506	414	358	320	292	271	253	239
	1700	40.2	407	533	435	377	337	308	285	267	251
	1900	45.0	431	558	456	395	353	322	299	279	263
	2100	49.7	453	583	476	412	369	336	312	291	275
	2300	54.4	474	604	493	427	382	349	323	302	285
4	300	7.1	121	171	140	121	108	99	92	86	81
	500	11.8	156	221	181	157	140	128	118	111	104
	700	16.6	185	262	214	185	166	151	140	131	123
	900	21.3	210	294	240	208	186	170	157	147	139
	1100	26.0	232	317	259	224	201	183	169	159	149
	1300	30.8	252	328	276	239	214	195	181	169	159
	1500	35.5	271	358	292	253	226	207	191	179	169
	1700	40.2	288	377	308	267	238	218	201	188	178
	1900	45.0	305	395	322	279	250	228	211	197	186
	2100	49.7	320	412	336	291	261	238	220	206	194
	2300	54.4	335	427	349	302	270	247	228	213	201
6	300	7.1	99	140	114	99	89	81	75	70	66
	500	11.8	128	181	148	128	114	104	97	90	85
	700	16.6	151	214	175	151	135	123	114	107	101
	900	21.3	171	240	196	170	152	139	128	120	113
	1100	26.0	189	259	211	183	164	149	138	129	122
	1300	30.8	206	276	225	195	175	159	148	138	130
	1500	35.5	221	292	239	207	185	169	156	146	138
	1700	40.2	235	308	251	218	195	178	165	154	145
	1900	45.0	249	322	263	228	204	186	172	161	152
	2100	49.7	261	336	275	238	213	194	180	168	159
	2300	54.4	274	349	285	247	220	201	186	174	164
8	300	7.1	86	121	99	86	77	70	65	61	57
	500	11.8	110	157	128	111	99	90	84	78	74
	700	16.6	131	185	151	131	117	107	99	93	87
	900	21.3	148	208	170	147	132	120	111	104	98
	1100	26.0	164	224	183	159	142	129	120	112	106
	1300	30.8	178	239	195	169	151	138	128	120	113
	1500	35.5	191	253	207	179	160	146	135	127	119
	1700	40.2	204	267	218	188	169	154	142	133	126
	1900	45.0	215	279	228	197	177	161	149	140	132
	2100	49.7	226	291	238	206	184	168	156	146	137
	2300	54.4	237	302	247	213	191	174	161	151	142
10	300	7.1	77	108	89	77	69	63	58	54	51
	500	11.8	99	140	114	99	89	81	75	70	66
	700	16.6	117	166	135	117	105	96	89	83	78
	900	21.3	133	186	152	132	118	107	100	93	88
	1100	26.0	147	201	164	142	127	116	107	100	95
	1300	30.8	159	214	175	151	135	123	114	107	101
	1500	35.5	171	226	185	160	143	131	121	113	107
	1700	40.2	182	238	195	169	151	138	127	119	112
	1900	45.0	193	250	204	177	158	144	134	125	118
	2100	49.7	203	261	213	184	165	150	139	130	123
	2300	54.4	212	270	220	191	171	156	144	135	127
12	300	7.1	70	99	81	70	63	57	53	49	47
	500	11.8	90	128	104	90	81	74	68	64	60
	700	16.6	107	151	123	107	96	87	81	76	71
	900	21.3	121	170	139	120	107	98	91	85	80
	1100	26.0	134	183	149	129	116	106	98	92	86
	1300	30.8	145	195	159	138	123	113	104	98	92
	1500	35.5	156	207	169	146	131	119	111	103	97
	1700	40.2	166	218	178	154	138	126	116	109	103
	1900	45.0	176	228	186	161	144	132	122	114	107
	2100	49.7	185	238	194	168	150	137	127	119	112
	2300	54.4	193	247	201	174	156	142	132	123	116

h = Distance from support surface to centroid of EPA.

Vmax = Effective wind velocity based on strength or overturning.

Vs = Effective wind velocity resulting in sliding on a flat surface with a .50 coefficient of friction.

NOTE: Mast strength may govern antenna capacity.

BRM4 BALLAST REQUIREMENTS

Effective Projected Area (EPA) (FT ²)	Ballast (LBS)	Zero Velocity Load (PSF)	Vs (MPH)	Vmax at centroid of projected area, (MPH)							
				h=2 FT	h=3 FT	h=4 FT	h=5 FT	h=6 FT	h=7 FT	h=8 FT	h=9 FT
14	300	7.1	65	92	75	65	58	53	49	46	43
	500	11.8	84	118	97	84	75	68	63	59	56
	700	16.6	99	140	114	99	89	81	75	70	66
	900	21.3	112	157	128	111	100	91	84	79	74
	1100	26.0	124	169	138	120	107	98	91	85	80
	1300	30.8	135	181	148	128	114	104	97	90	85
	1500	35.5	145	191	156	135	121	111	102	96	90
	1700	40.2	154	201	165	142	127	116	108	101	95
	1900	45.0	163	211	172	149	134	122	113	106	100
	2100	49.7	171	220	180	156	139	127	118	110	104
2300	54.4	179	228	186	161	144	132	122	114	108	
16	300	7.1	61	86	70	61	54	49	46	43	40
	500	11.8	78	111	90	78	70	64	59	55	52
	700	16.6	92	131	107	93	83	76	70	65	62
	900	21.3	105	147	120	104	93	85	79	74	69
	1100	26.0	116	159	129	112	100	92	85	79	75
	1300	30.8	126	169	138	120	107	98	90	85	80
	1500	35.5	135	179	146	127	113	103	96	90	84
	1700	40.2	144	188	154	133	119	109	101	94	89
	1900	45.0	152	197	161	140	125	114	106	99	93
	2100	49.7	160	206	168	146	130	119	110	103	97
2300	54.4	168	213	174	151	135	123	114	107	101	
18	300	7.1	57	81	66	57	51	47	43	40	38
	500	11.8	74	104	85	74	66	60	56	52	49
	700	16.6	87	123	101	87	78	71	66	62	58
	900	21.3	99	139	113	98	88	80	74	69	65
	1100	26.0	109	149	122	106	95	86	80	75	70
	1300	30.8	119	159	130	113	101	92	85	80	75
	1500	35.5	128	169	138	119	107	97	90	84	80
	1700	40.2	136	178	145	126	112	103	95	89	84
	1900	45.0	144	186	152	132	118	107	100	93	88
	2100	49.7	151	194	159	137	123	112	104	97	92
2300	54.4	158	201	164	142	127	116	108	101	95	
20	300	7.1	54	77	63	54	48	44	41	38	36
	500	11.8	70	99	81	70	63	57	53	49	47
	700	16.6	83	117	96	83	74	68	63	59	55
	900	21.3	94	132	107	93	83	76	70	66	62
	1100	26.0	104	142	116	100	90	82	76	71	67
	1300	30.8	113	151	123	107	96	87	81	76	71
	1500	35.5	121	160	131	113	101	92	86	80	75
	1700	40.2	129	169	138	119	107	97	90	84	79
	1900	45.0	136	177	144	125	112	102	94	88	83
	2100	49.7	143	184	150	130	117	106	99	92	87
2300	54.4	150	191	156	135	121	110	102	95	90	
22	300	7.1	52	73	60	52	46	42	39	37	34
	500	11.8	67	94	77	67	60	54	50	47	44
	700	16.6	79	112	91	79	71	64	60	56	53
	900	21.3	89	126	102	89	79	72	67	63	59
	1100	26.0	99	135	110	96	86	78	72	68	64
	1300	30.8	107	144	118	102	91	83	77	72	68
	1500	35.5	115	153	125	108	97	88	82	76	72
	1700	40.2	123	161	131	114	102	93	86	80	76
	1900	45.0	130	168	137	119	106	97	90	84	79
	2100	49.7	137	176	143	124	111	101	94	88	83
2300	54.4	143	182	149	129	115	105	97	91	86	
24	300	7.1	49	70	57	49	44	40	37	35	33
	500	11.8	64	90	74	64	57	52	48	45	43
	700	16.6	75	107	87	76	68	62	57	53	50
	900	21.3	86	120	98	85	76	69	64	60	57
	1100	26.0	95	129	106	92	82	75	69	65	61
	1300	30.8	103	138	113	98	87	80	74	69	65
	1500	35.5	110	146	119	103	92	84	78	73	69
	1700	40.2	118	154	126	109	97	89	82	77	73
	1900	45.0	124	161	132	114	102	93	86	81	76
	2100	49.7	131	168	137	119	106	97	90	84	79
2300	54.4	137	174	142	123	110	101	93	87	82	

h = Distance from support surface to centroid of EPA.

Vmax = Effective wind velocity based on strength or overturning.

Vs = Effective wind velocity resulting in sliding on a flat surface with a .50 coefficient of friction.

NOTE: Mast strength may govern antenna capacity.

BRM6 NON-PENETRATING

The BRM6 mount is hot-dip galvanized after fabrication for corrosion protection.

Order (1) optional BRM6MAT (1/8" thick) or (1) optional BRM6PAD (3/8" thick) for a protective barrier between the mount and the roof. Order (1) optional SCK150 safety cable kit (3/16" x 150').

Optional additional inner ballast support angle kit available, order P/N BRM6ABK.

Refer to pages 261-263 for ballast requirements.

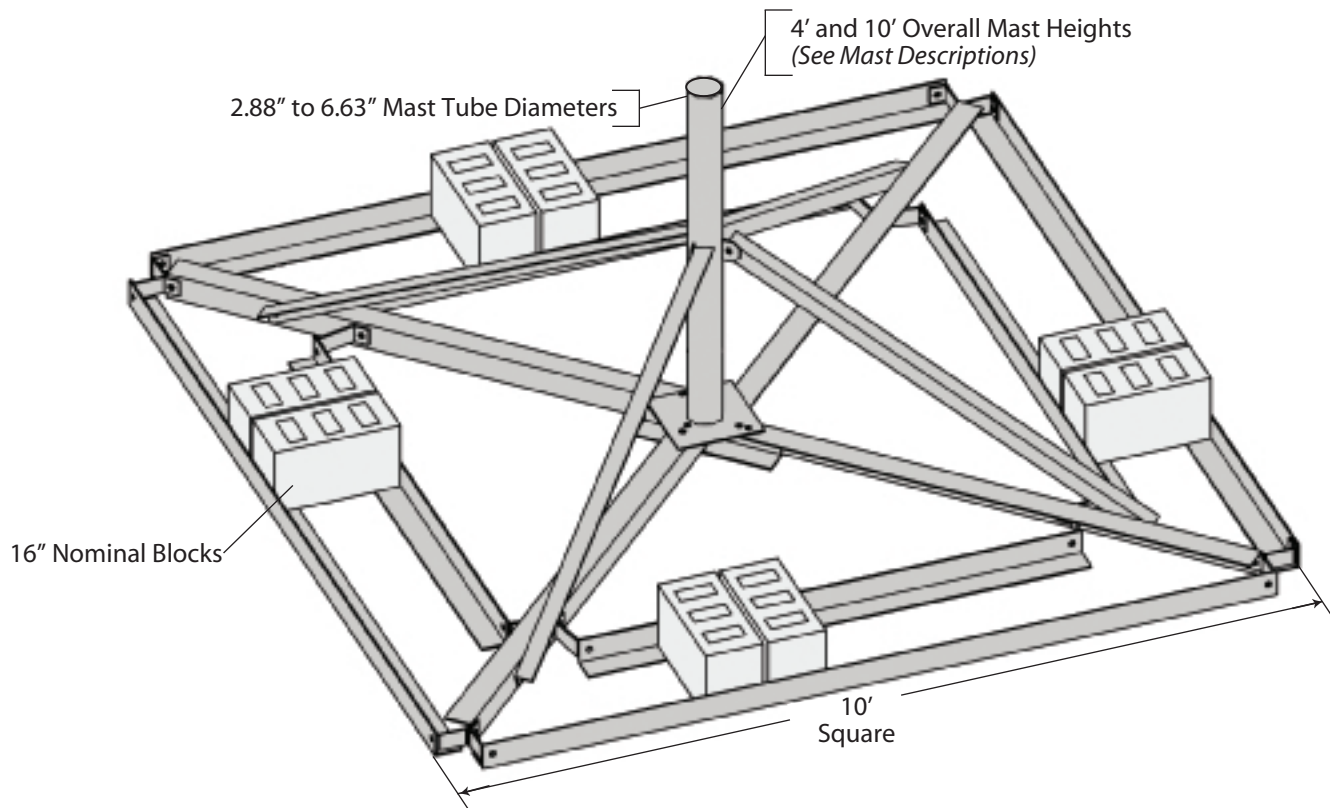

MAST SPECIFICATIONS

Mount Part No.	Mast Part No.	Mast Description & Height
BRM630M	KY2110	2.88" O.D. x 0.203" wall x 4.0'
BRM635M	KY1570	3.50" O.D. x 0.216" wall x 4.0'
BRM640M	KY1578	4.00" O.D. x 0.226" wall x 4.0'
BRM645M	KY1579	4.50" O.D. x 0.237" wall x 4.0'
BRM655M	KY1580	5.56" O.D. x 0.258" wall x 4.0'
BRM665M	KY1581	6.63" O.D. x 0.280" wall x 4.0'
BRM64510M	KY2043	4.50" O.D. x 0.237" wall x 10.0'

BRM6 4 FT. DISH ELEVATION BALLAST REQUIREMENTS

Dish Diameter	Ballast (LBS)	Zero Velocity Load (PSF)	Design Wind Velocities (MPH)					
			EL=0°		EL=20°		EL=40°	
			Vmax	Vs	Vmax	Vs	Vmax	Vs
4' (1.2 m)	500	5.0	87	67	103	75	112	92
	750	7.5	107	82	131	92	142	113
	1000	10.0	125	95	154	107	167	131
	1250	12.5	139	106	169	119	189	146
	1500	15.0	148	117	180	131	203	160
	1750	17.5	157	126	190	141	211	173
	2000	20.0	165	135	196	151	211	185
6' (1.8 m)	500	5.0	58	45	65	50	69	61
	750	7.5	71	55	83	61	89	75
	1000	10.0	83	63	99	71	106	87
	1250	12.5	93	71	112	79	120	97
	1500	15.0	99	78	120	87	129	107
	1750	17.5	105	84	127	94	137	115
	2000	20.0	110	90	130	101	141	123
	2250	22.5	115	95	130	107	141	131
	2500	25.0	120	100	130	113	141	138
	2750	27.5	125	105	130	118	141	141
3000	30.0	127	110	130	123	141	141	
8' (2.4 m)	750	7.5	53	41	57	46	60	56
	1000	10.0	62	47	69	53	73	65
	1250	12.5	69	53	79	59	84	73
	1500	15.0	74	58	85	65	90	80
	1750	17.5	78	63	91	70	96	86
	2000	20.0	82	67	97	75	102	92
	2250	22.5	86	71	98	80	103	98
	2500	25.0	90	75	98	84	103	103
	2750	27.5	94	79	98	88	103	103
	3000	30.0	95	82	98	92	103	103

EL = Dish antenna azimuth angle with horizontal.

Vmax = Effective wind velocity based on strength or overturning.

Vs = Effective wind velocity resulting in sliding on a flat surface with a .50 coefficient of friction.

NOTE: Mast strength may govern antenna capacity.



BRM6 BALLAST REQUIREMENTS

Effective Projected Area (EPA) (FT ²)	Ballast (LBS)	Zero Velocity Load (PSF)	Vs (MPH)	Vmax at centroid of projected area, (MPH)						
				h=4 FT	h=5 FT	h=6 FT	h=7 FT	h=8 FT	h=9 FT	h=10 FT
10	500	5.0	99	128	114	104	96	90	85	81
	750	7.5	121	156	140	128	118	110	104	99
	1000	10.0	140	180	161	147	136	128	120	114
	1250	12.5	156	202	180	165	152	143	134	128
	1500	15.0	171	218	195	178	165	154	145	138
	1750	17.5	185	230	206	188	174	163	154	146
	2000	20.0	198	242	217	198	183	171	162	153
	2250	22.5	210	254	227	207	192	179	169	160
	2500	25.0	221	265	237	216	200	187	176	167
	2750	27.5	232	275	246	225	208	195	183	174
3000	30.0	242	280	250	228	211	198	186	177	
15	500	5.0	81	104	93	85	79	74	69	66
	750	7.5	99	128	114	104	96	90	85	81
	1000	10.0	114	147	132	120	111	104	98	93
	1250	12.5	128	165	147	134	125	116	110	104
	1500	15.0	140	178	159	145	134	126	119	113
	1750	17.5	151	188	168	154	142	133	125	119
	2000	20.0	161	198	177	162	150	140	132	125
	2250	22.5	171	207	185	169	157	147	138	131
	2500	25.0	180	216	193	176	163	153	144	137
	2750	27.5	189	225	201	183	170	159	150	142
3000	30.0	198	228	204	186	173	161	152	144	
20	500	5.0	70	90	81	74	68	64	60	57
	750	7.5	86	110	99	90	84	78	74	70
	1000	10.0	99	128	114	104	96	90	85	81
	1250	12.5	110	143	128	116	108	101	95	90
	1500	15.0	121	154	138	126	116	109	103	97
	1750	17.5	131	163	146	133	123	115	109	103
	2000	20.0	140	171	153	140	130	121	114	108
	2250	22.5	148	179	160	147	136	127	120	113
	2500	25.0	156	187	167	153	141	132	125	118
	2750	27.5	164	195	174	159	147	138	130	123
3000	30.0	171	198	177	161	149	140	132	125	
25	500	5.0	63	81	72	66	61	57	54	51
	750	7.5	77	99	88	81	75	70	66	63
	1000	10.0	88	114	102	93	86	81	76	72
	1250	12.5	99	128	114	104	96	90	85	81
	1500	15.0	108	138	123	113	104	97	92	87
	1750	17.5	117	146	130	119	110	103	97	92
	2000	20.0	125	153	137	125	116	108	102	97
	2250	22.5	133	160	144	131	121	113	107	101
	2500	25.0	140	167	150	137	127	118	112	106
	2750	27.5	147	174	156	142	132	123	116	110
3000	30.0	153	177	158	144	134	125	118	112	
30	500	5.0	57	74	66	60	56	52	49	47
	750	7.5	70	90	81	74	68	64	60	57
	1000	10.0	81	104	93	85	79	74	69	66
	1250	12.5	90	116	104	95	88	82	78	74
	1500	15.0	99	126	113	103	95	89	84	80
	1750	17.5	107	133	119	109	101	94	89	84
	2000	20.0	114	140	125	114	106	99	93	89
	2250	22.5	121	147	131	120	111	104	98	93
	2500	25.0	128	153	137	125	115	108	102	97
	2750	27.5	134	159	142	130	120	112	106	100
3000	30.0	140	161	144	132	122	114	108	102	
35	500	5.0	53	68	61	56	52	48	45	43
	750	7.5	65	84	75	68	63	59	56	53
	1000	10.0	75	96	86	79	73	68	64	61
	1250	12.5	84	108	96	88	82	76	72	68
	1500	15.0	91	116	104	95	88	82	78	74
	1750	17.5	99	123	110	101	93	87	82	78
	2000	20.0	106	130	116	106	98	92	86	82
	2250	22.5	112	136	121	111	103	96	90	86
	2500	25.0	118	141	127	115	107	100	94	89
	2750	27.5	124	147	132	120	111	104	98	93
3000	30.0	129	149	134	122	113	106	100	94	

EL = Dish antenna angle with horizontal.

Vmax = Effective wind velocity based on strength or overturning.

Vs = Effective wind velocity resulting in sliding on a flat surface with a .50 coefficient of friction.

NOTE: Mast strength may govern antenna capacity.



BRM6 BALLAST REQUIREMENTS

Effective Projected Area (EPA) (FT ²)	Ballast (LBS)	Zero Velocity Load (PSF)	Vs (MPH)	Vmax at centroid of projected area, (MPH)						
				h=4 FT	h=5 FT	h=6 FT	h=7 FT	h=8 FT	h=9 FT	h=10 FT
40	500	5.0	49	64	57	52	48	45	43	40
	750	7.5	61	78	70	64	59	55	52	49
	1000	10.0	70	90	81	74	68	64	60	57
	1250	12.5	78	101	90	82	76	71	67	64
	1500	15.0	86	109	97	89	82	77	73	69
	1750	17.5	92	115	103	94	87	81	77	73
	2000	20.0	99	121	108	99	92	86	81	77
	2250	22.5	105	127	113	104	96	90	85	80
	2500	25.0	110	132	118	108	100	94	88	84
	2750	27.5	116	138	123	112	104	97	92	87
3000	30.0	121	140	125	114	106	99	93	88	
45	500	5.0	47	60	54	49	45	43	40	38
	750	7.5	57	74	66	60	56	52	49	47
	1000	10.0	66	85	76	69	64	60	57	54
	1250	12.5	74	95	85	78	72	67	63	60
	1500	15.0	81	103	92	84	78	73	68	65
	1750	17.5	87	109	97	89	82	77	72	69
	2000	20.0	93	114	102	93	86	81	76	72
	2250	22.5	99	120	107	98	90	85	80	76
	2500	25.0	104	125	112	102	94	88	83	79
	2750	27.5	109	130	116	106	98	92	86	82
3000	30.0	114	132	118	108	100	93	88	83	
50	500	5.0	44	57	51	47	43	40	38	36
	750	7.5	54	70	63	57	53	49	47	44
	1000	10.0	63	81	72	66	61	57	54	51
	1250	12.5	70	90	81	74	68	64	60	57
	1500	15.0	77	97	87	80	74	69	65	62
	1750	17.5	83	103	92	84	78	73	69	65
	2000	20.0	88	108	97	89	82	77	72	69
	2250	22.5	94	113	101	93	86	80	76	72
	2500	25.0	99	118	106	97	89	84	79	75
	2750	27.5	104	123	110	100	93	87	82	78
3000	30.0	108	125	112	102	94	88	83	79	

EL = Dish antenna angle with horizontal.

Vmax = Effective wind velocity based on strength or overturning.

Vs = Effective wind velocity resulting in sliding on a flat surface with a .50 coefficient of friction.

NOTE: Mast strength may govern antenna capacity.

NPPK NON-PENETRATING

The NPPK mount is a great solution for broadband antennas and satellite TV dishes. The adjustable mounting plate can be center mounted or to one side as needed to accommodate other satellite TV dish mounts. Our 1LG mount (located on page 274) with a base and 1-1/4" mounting tube can be attached to the NPPK. The mount comes standard with double ballast trays on each side to hold concrete blocks. The NPPK mount is hot-dip galvanized after fabrication for corrosion protection.

Order (2) optional FRMMAT (1/8" thick) or (2) optional FRMPAD (3/8" thick) for a protective barrier between the mount and the roof.
Order (1) optional SCK150 safety cable kit (3/16" x 150').

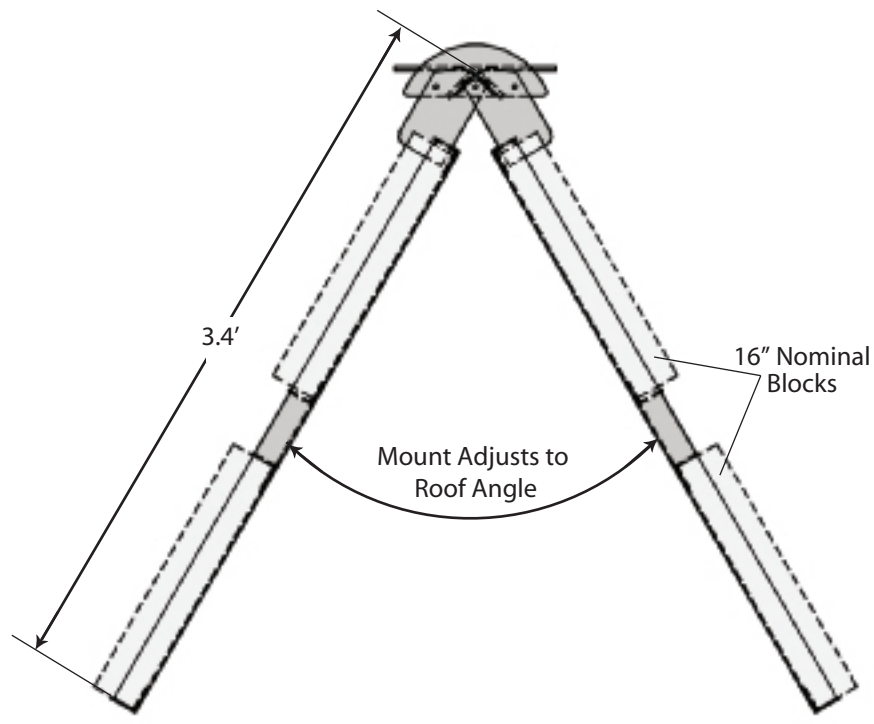
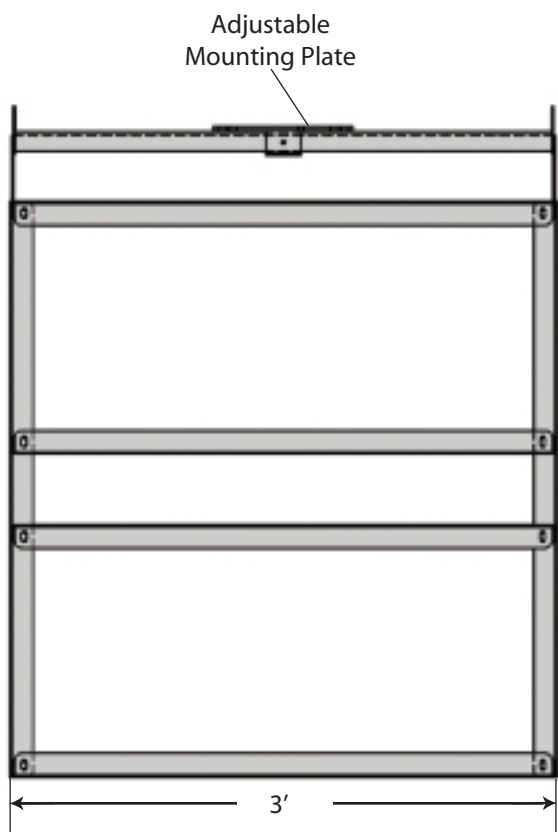

25GBRM NON-PENETRATING

The 25GBRM mount is designed to support one or two 25G tower sections in a self-supporting application. The 25GBRM mount is galvanized after fabrication for corrosion protection.

Order (1) optional BRM6MAT (1/8" thick) or (1) optional BRM6PAD (3/8" thick) for a protective barrier between the mount and the roof. Order (1) optional SCK150 safety cable kit (3/16" x 150').

Refer to page 266 for ballast requirements.

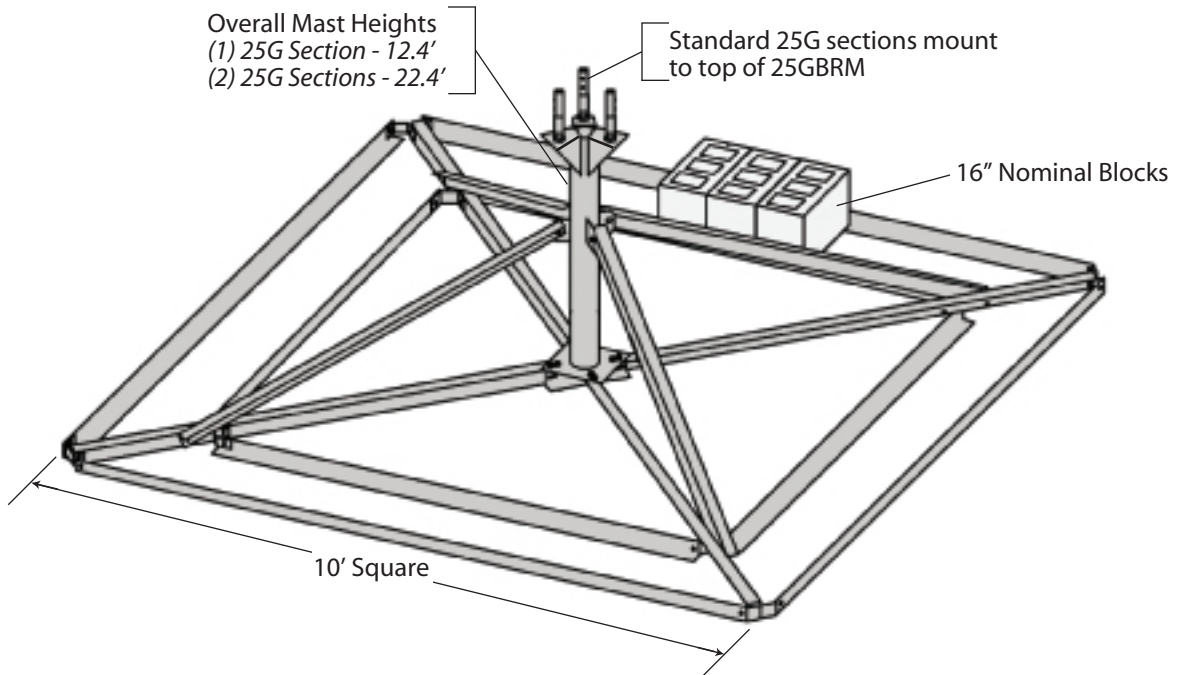

25GBRM BALLAST REQUIREMENTS

Effective Projected Area (EPA) (FT ²)	Ballast (LBS)	Zero Velocity Load (PSF)	Vs One Section (MPH) h=12.4 FT	Vs Two Sections (MPH) h=22.4 FT	Vmax at centroid of projected area, (MPH)	
					1 Section h=12.4 FT	2 Sections h=22.4 FT
					2	500
	750	7.5	160	117	136	80
	1000	10.0	185	135	157	92
	1250	12.5	207	151	176	103
	1500	15.0	227	165	190	111
	1750	17.5	245	179	201	118
	2000	20.0	250	191	211	124
	2250	22.5	250	203	221	130
	2500	25.0	250	214	231	135
	2750	27.5	250	224	240	140
	3000	30.0	250	234	244	143
4	500	5.0	113	88	92	57
	750	7.5	138	107	112	70
	1000	10.0	159	124	130	81
	1250	12.5	178	139	145	91
	1500	15.0	195	152	157	98
	1750	17.5	211	164	166	104
	2000	20.0	225	175	174	109
	2250	22.5	239	186	182	114
	2500	25.0	250	196	190	119
	2750	27.5	250	206	198	124
	3000	30.0	250	215	201	126
6	500	5.0	100	82	80	52
	750	7.5	123	100	98	63
	1000	10.0	142	115	113	73
	1250	12.5	159	129	126	82
	1500	15.0	174	141	136	88
	1750	17.5	188	152	144	94
	2000	20.0	201	163	152	98
	2250	22.5	213	173	159	103
	2500	25.0	224	182	166	107
	2750	27.5	235	191	172	112
	3000	30.0	246	200	175	113
8	500	5.0	91	76	72	48
	750	7.5	112	94	88	58
	1000	10.0	129	108	101	67
	1250	12.5	144	121	113	75
	1500	15.0	158	132	122	81
	1750	17.5	171	143	129	86
	2000	20.0	183	153	136	90
	2250	22.5	194	162	142	95
	2500	25.0	204	171	149	99
	2750	27.5	214	179	154	103
	3000	30.0	224	187	157	104
10	500	5.0	84	72	66	44
	750	7.5	103	89	80	54
	1000	10.0	119	102	93	63
	1250	12.5	133	114	104	70
	1500	15.0	146	125	112	76
	1750	17.5	158	135	118	80
	2000	20.0	169	145	124	84
	2250	22.5	179	153	130	88
	2500	25.0	189	162	136	92
	2750	27.5	198	169	141	95
	3000	30.0	207	177	144	97
12	500	5.0	79	69	61	42
	750	7.5	97	84	74	51
	1000	10.0	112	97	86	59
	1250	12.5	125	109	96	66
	1500	15.0	137	119	104	71
	1750	17.5	148	128	110	75
	2000	20.0	158	137	115	79
	2250	22.5	167	146	121	83
	2500	25.0	176	154	126	86
	2750	27.5	185	161	131	90
	3000	30.0	193	168	133	91

Effective Projected Area (EPA) (FT ²)	Ballast (LBS)	Zero Velocity Load (PSF)	Vs One Section (MPH) h=12.4 FT	Vs Two Sections (MPH) h=22.4 FT	Vmax at centroid of projected area, (MPH)	
					1 Section h=12.4 FT	2 Sections h=22.4 FT
					14	500
	750	7.5	91	80	70	48
	1000	10.0	105	93	80	56
	1250	12.5	117	104	90	62
	1500	15.0	129	114	97	67
	1750	17.5	139	123	103	71
	2000	20.0	149	131	108	75
	2250	22.5	158	139	113	78
	2500	25.0	166	147	118	81
	2750	27.5	174	154	123	85
	3000	30.0	182	161	125	86
16	500	5.0	70	63	54	37
	750	7.5	86	77	66	46
	1000	10.0	100	89	76	53
	1250	12.5	111	99	85	59
	1500	15.0	122	109	92	64
	1750	17.5	132	118	97	67
	2000	20.0	141	126	102	71
	2250	22.5	149	133	107	74
	2500	25.0	157	141	111	77
	2750	27.5	165	147	116	80
	3000	30.0	172	154	118	82
18	500	5.0	67	60	51	36
	750	7.5	82	74	62	44
	1000	10.0	95	86	72	50
	1250	12.5	106	96	81	56
	1500	15.0	116	105	87	61
	1750	17.5	126	113	92	64
	2000	20.0	134	121	97	68
	2250	22.5	142	128	101	71
	2500	25.0	150	135	106	74
	2750	27.5	157	142	110	77
	3000	30.0	164	148	112	78

h = Distance from support surface to centroid of EPA.
Vs = Effective wind velocity resulting in sliding on a flat surface with a .50 coefficient of friction.
Vmax = Effective wind velocity based on strength or overturning.

AAGM NON-PENETRATING

The AAGM mount is capable of supporting dishes with diameters up to 10 feet. The AAGM mount is hot-dip galvanized after fabrication for corrosion protection.

Order (1) optional AGMMAT (1/8" thick) or (1) optional AGMPAD (3/8" thick) for a protective barrier between the mount and the roof.
Order (1) optional SCK150 safety cable kit (3/16" x 150').

Refer to page 268 for ballast requirements.

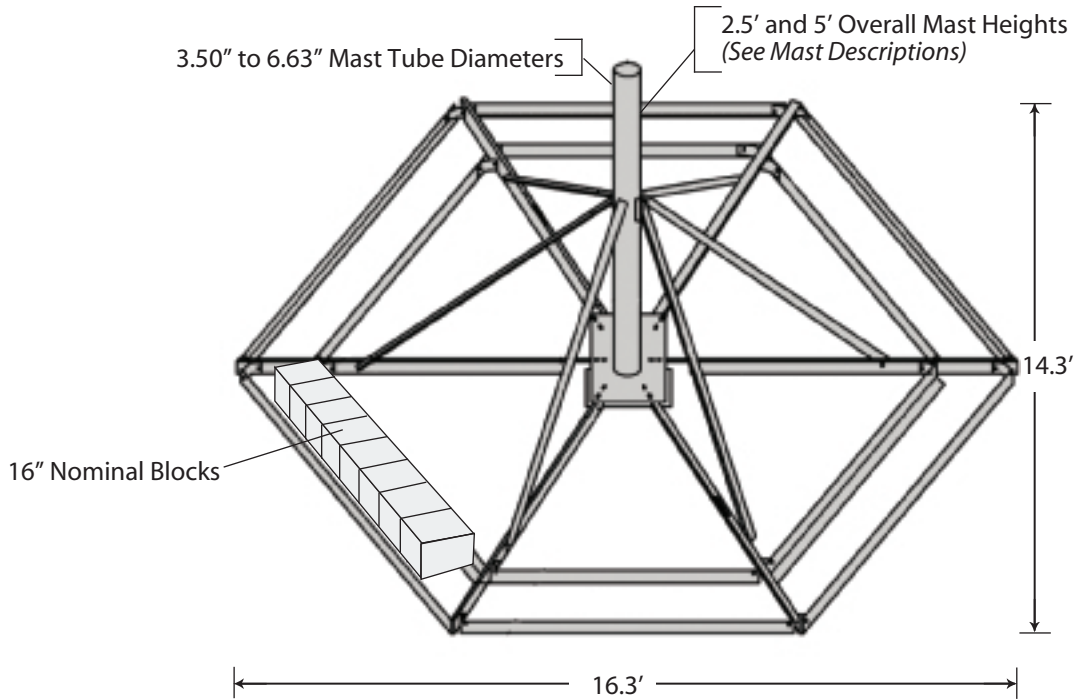

MAST SPECIFICATIONS

Mount Part No.	Mast Part No.	Mast Description & Height
AAGM35	FYS75	3.50" O.D. x 0.216" wall x 4.5'
AAGM40	FYS76	4.00" O.D. x 0.226" wall x 4.5'
AAGM45	FYS77	4.50" O.D. x 0.237 wall x 4.5'
AAGM55	FYS78	5.56" O.D. x 0.258" wall x 4.5'
AAGM6560	FYS96	6.63" O.D. x 0.280" wall x 5.0'



AAGM 4.5 FT DISH ELEVATION BALLAST REQUIREMENTS

Dish Diameter	Ballast (LBS)	Zero Velocity Load (PSF)	Vmax (MPH)	Vs (MPH)		
				EL=0°	EL=20°	EL=40°
4' (1.2 m)	1000	6.0	135	91	93	101
	1500	9.0	164	111	114	123
	2000	12.0	187	128	132	142
	2500	15.1	207	143	147	159
	3000	18.1	225	157	161	174
	3500	21.1	240	170	174	188
	4000	24.1	250	181	186	201
	5000	30.1	250	203	208	225
6000	36.1	250	222	228	246	
6' (1.8 m)	1000	6.0	90	60	62	67
	1500	9.0	109	74	76	82
	2000	12.0	125	85	88	95
	2500	15.1	138	96	98	106
	3000	18.1	150	105	108	116
	3500	21.1	160	113	116	125
	4000	24.1	165	121	124	134
	5000	30.1	165	135	139	150
6000	36.1	165	148	152	164	
8' (2.4 m)	1000	6.0	68	45	47	50
	1500	9.0	82	56	57	62
	2000	12.0	94	64	66	71
	2500	15.1	104	72	74	79
	3000	18.1	112	79	81	87
	3500	21.1	120	85	87	94
	4000	24.1	125	91	93	101
	5000	30.1	125	101	104	112
6000	36.1	125	111	114	123	
10' (3.0 m)	1000	6.0	46	31	33	40
	1500	9.0	56	38	40	49
	2000	12.0	64	44	46	57
	2500	15.1	71	49	52	64
	3000	18.1	77	54	57	70
	3500	21.1	82	58	61	75
	4000	24.1	85	62	65	80
	5000	30.1	85	69	73	85
6000	36.1	85	76	80	85	

EL = Dish antenna azimuth angle with horizontal.

Vmax = Effective wind velocity based on strength or overturning.

Vs = Effective wind velocity resulting in sliding on a flat surface with a .50 coefficient of friction.

NOTE: Mast strength may govern antenna capacity.

PRM6 NON-PENETRATING

The PRM6 mount is capable of supporting dishes with diameters up to 6 feet. The mount is hot-dip galvanized after fabrication for corrosion protection. The PRM6 mount is also UPS shippable.

Order (1) optional PRM6MAT (1/8" thick) or (1) optional PRM6PAD (3/8" thick) for a protective barrier between the mount and the roof.
Order (1) optional SCK150 safety cable kit (3/16" x 150').

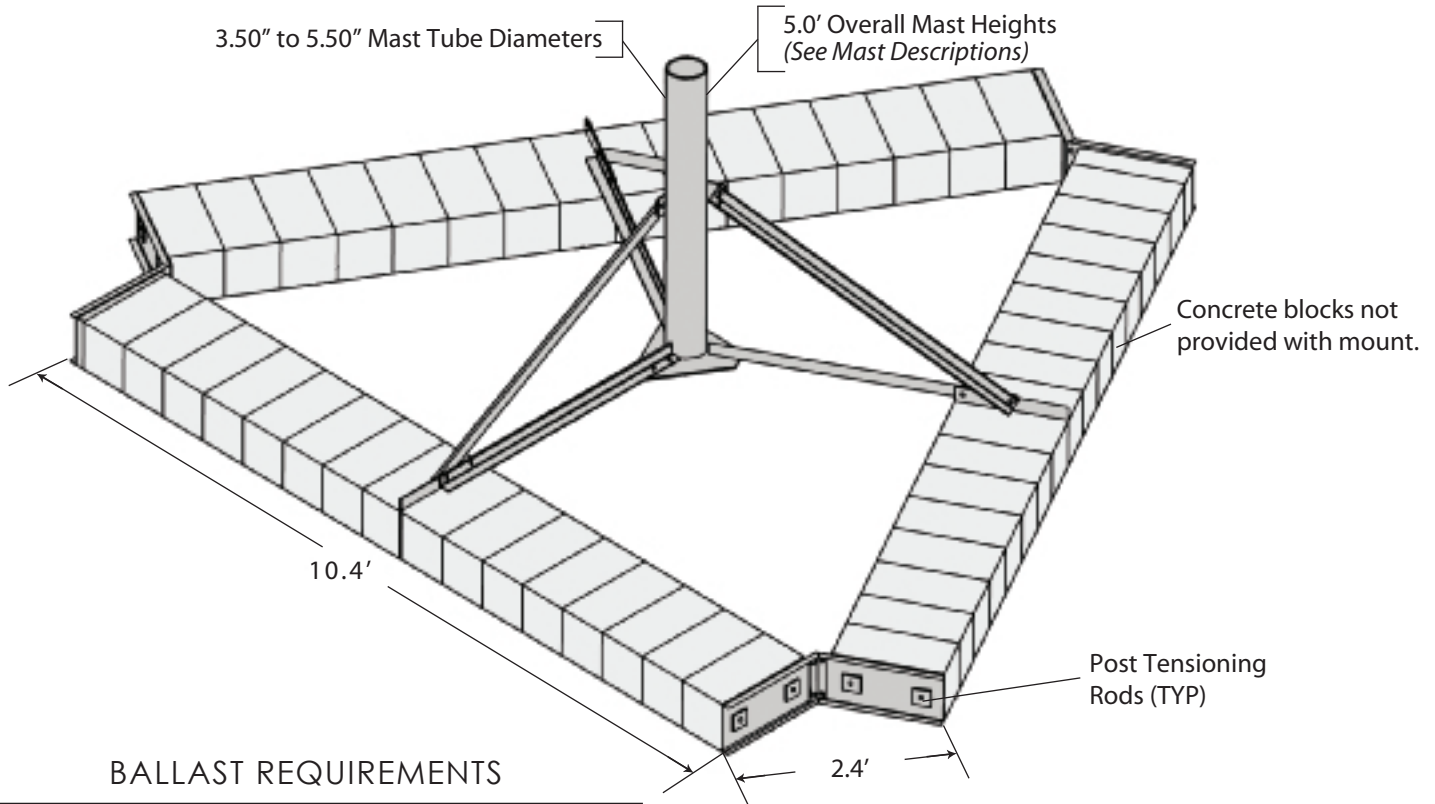

BALLAST REQUIREMENTS

Dish Diameter	Ballast (LBS)	Zero Velocity Load (PSF)	Design Wind Velocities (MPH)					
			EL=0°		EL=20°		EL=40°	
			V _{max}	V _s	V _{max}	V _s	V _{max}	V _s
4' (1.2 m)	1600	17.2	145	122	180	137	198	168
	1800	19.4	154	130	184	146	198	179
	2000	21.5	162	137	187	154	198	188
	2200	23.7	168	144	189	161	198	197
	2400	25.8	171	150	189	168	198	198
6' (1.8 m)	1600	17.2	97	81	117	91	126	112
	1800	19.4	102	86	123	97	132	119
	2000	21.5	108	91	125	102	132	125
	2200	23.7	112	96	126	107	132	131
	2400	25.8	114	100	126	112	132	132
	2600	28.0	116	104	126	117	132	132
	2800	30.1	118	108	126	121	132	132
	3000	32.3	120	112	126	125	132	132
	3200	34.4	122	115	126	126	132	132
	3400	36.6	124	119	126	126	132	132
	3600	38.7	125	122	126	126	132	132
	3800	40.9	125	125	126	126	132	132

MAST SPECIFICATIONS

Mount Part No.	Mast Part No.	Mast Description
PRM635	KY1672	3.50" O.D. x 0.216" wall
PRM640	KY1673	4.00" O.D. x 0.226" wall
PRM645	KY1674	4.50" O.D. x 0.237" wall
PRM655	KY1675	5.50" O.D. x 0.258" wall

EL = Dish antenna azimuth angle with horizontal.

V_{max} = Effective wind velocity based on strength or overturning.

V_s = Effective wind velocity resulting in sliding on a flat surface with a .50 coefficient of friction.

NOTE: Mast strength may govern antenna capacity.

BALLAST REQUIREMENTS FOR ROOF MOUNTS

1. Ballast requirements are provided to assist consumers in determining the applicability of a non-penetrating roof mount for an antenna installation and to assist in determining the amount of ballast required. The ballast requirements should not be relied upon without competent local professional examination and verification of its accuracy and suitability for a specific site or application.
2. Specific antennas and/or other mounting configurations may require more stringent strength and ballast requirements and must be investigated for each installation. The load carrying requirements of the supporting surface, the mount and mast, the antenna and the antenna's connection to the mast must be investigated for each installation.
3. When antenna areas are indicated vs. specific antenna types, the areas tabulated are effective projected areas that include appropriate wind drag factors applied to the projected areas of the supported antennas and the exposed portions of the mount and ballast. The center of the effective projected area is assumed to be at the top of the mounting pipe or the height indicated in the ballast table. Unless otherwise indicated, tabulated ballast requirements assume that the effective projected areas are concentric to the mount and that uplift or download wind forces are insignificant.
4. The tabulated wind velocities are considered to occur at the centroid of the effective projected areas. The wind velocity appropriate for an installation must be determined on an individual site basis considering the location and elevation of the mount. The wind velocity at ground level must be multiplied by appropriate height escalation and gust factors. Potential increases in wind velocity due to channeling, roof projections, and other obstructions, must also be considered when determining ballast requirements.
5. The ballast weights indicated are assumed to be uniformly distributed on the mount. The weight of the mount and antenna may be considered as ballast. Mounts are assumed to be mounted on a flat supporting surface.
6. The zero velocity loads shown are equal to the tabulated ballast weights divided by the total area enclosed by the perimeter of the mount. This area is greater than the ballast contact area. Loads which must be investigated include reactions caused by wind forces and moments, live loads, ice loads, earthquake loads and the dead loads of ballast, mount, antenna, mounting hardware, miscellaneous equipment and roof pads.
7. The tabulated maximum wind velocities (V_{max}) are based on a minimum 1.5 factor of safety against structural failure and overturning.
8. The tabulated wind velocities resulting in sliding (V_s) are based on a factor of safety equal to 1.0 and an effective coefficient of friction equal to 0.50 between the mount and a flat supporting surface. A 1.0 factor of safety was used assuming that at higher wind velocities, safety cables or other suitable attachments to the support structure would prevent sliding beyond a safe, designated area.
9. The appropriate coefficient of friction and factor of safety to determine wind velocities resulting in sliding must be determined on an individual site basis. The coefficient of friction may vary under changing moisture and temperature conditions. The minimum coefficient of friction must be used to evaluate sliding resistance. Wind speeds resulting in sliding for other factors of safety or for other coefficients of friction may be found by multiplying the tabulated values of V_s by the following modification factor:

$$\text{Modification Factor} = [\mu / (.5 \times FS)]^{1/2}$$

μ = Coefficient of Friction
 FS = Factor of Safety
10. The values of V_s indicated do not apply for installations which are prevented from sliding by cables or other suitable attachments to the supporting structure.
11. Roof pads are recommended to prevent damage to roof membranes. Pads should be placed under all contact areas.
12. ROHN recommends that ballast material always be placed prior to mounting the antenna and that roof pads and mount be secured to prevent hazards from occurring under extreme wind loading conditions. Precautions should also be taken to prevent the inadvertent removal of ballast material after installation and to insure that all ballast material is fully supported by the mount (required for ballast to be effective in resisting overturning and sliding).
13. When adhesives are used to secure roof pads, the adhesive must be compatible with the supporting surface. Precautions should be taken to insure that damage to the supporting surface will not occur upon wind loading.
14. The installation, roof material and supporting structure must be capable of withstanding all loads imposed by the antenna system. Supporting surfaces, anchors and/or safety cables must be sufficient to resist the reactions from the antenna system. The installation must meet all applicable local, state and federal requirements.

URM

ROHN's Universal Roof Mount (URM) is capable of supporting most PCS, Cellular, and Microwave antennas. The URM adapts to various roof pitches and the fully adjustable rear-leg allows for use on a flat or up to a 12"/12" pitched roof. Installation is easy because of the quick adaptability, plus there's no need for concrete blocks. The URM is hot-dip galvanized after fabrication for corrosion protection, and can easily ship UPS.

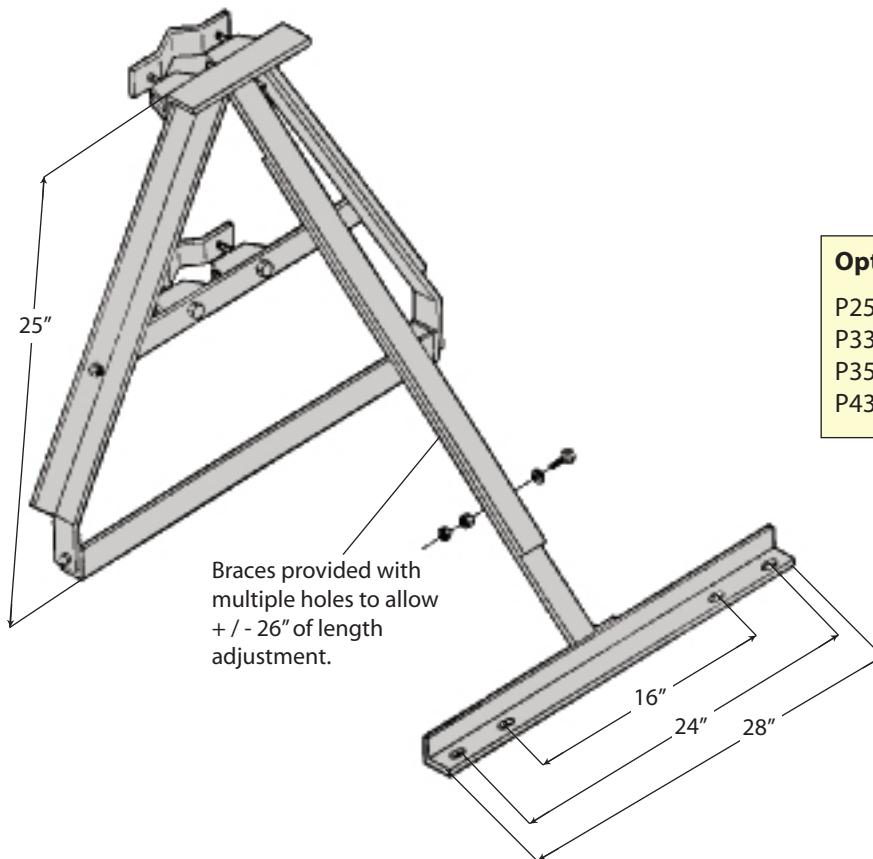

Optional Masts - Ordered Separately

P2530	2.88" O.D. x 0.203" wall x 30" Long
P330	3.50" O.D. x 0.216" wall x 30" Long
P3530	4.00" O.D. x 0.226" wall x 30" Long
P430	4.50" O.D. x 0.237" wall x 30" Long

Features:

1. URM mount can be used on a flat roof, sloped roof or over a roof peak.
2. URM mount can be used with 2.88" to 4.50" O.D. masts (order separately).
3. Bottom of mount pivots to match roof pitch.
4. Rear leg adjusts for extra length.
5. Mount base angles are pre-drilled to accept 1/2" diameter connectors.

SHRM

ROHN's Saw Horse Roof Mount (SHRM) is capable of supporting most PCS, Cellular, and Microwave antennas. The SHRM allows for placement of antennas on flat roofs or roof peaks with up to a 12"/12" pitch. The SHRM is also able to be installed on flat roofs. Installation is easy because of the quick adaptability, plus there's no need for concrete blocks. The SHRM is hot-dip galvanized after fabrication for corrosion protection, and can easily ship UPS.

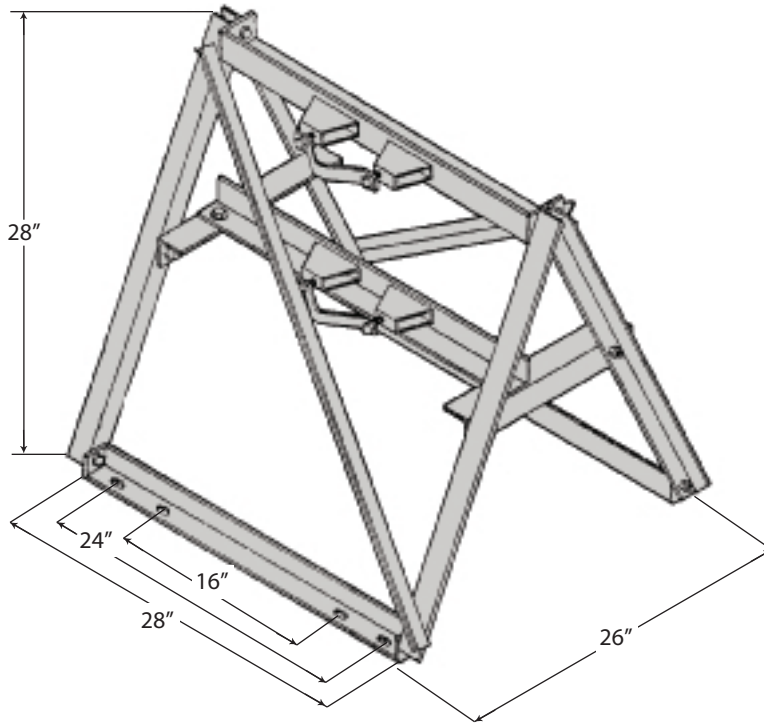

Optional Masts - Ordered Separately

P2530	2.88" O.D. x 0.203" wall x 30" Long
P330	3.50" O.D. x 0.216" wall x 30" Long
P3530	4.00" O.D. x 0.226" wall x 30" Long
P430	4.50" O.D. x 0.237" wall x 30" Long

Features:

1. SHRM mount can be used on a flat roof or on a roof peak, up to 45 degrees maximum pitch.
2. SHRM mount can be used with 2.88" to 5.00" O.D. masts (ordered separately).
3. Bottom of mount pivots to match roof pitch.
4. Mount base angles are pre-drilled to accept 1/2" diameter connectors.

TRT36 / TRT60 / TRTAG2

The TRT is a Tripod Roof Tower, which comes fully assembled and snaps out into position for quick installation using up to 1/4" dia. connectors. The TRTAG2 mount comes with a 2 3/8" O.D. hot-dip galvanized mast, the TRT36 and TRT60 mounts accept masts up to 1 3/4" O.D. (ordered separately). The bolt-on swivel feet adjust to most any pitch roof. TRT mounts are galvanized for corrosion protection. All TRT mounts are UPS shippable.

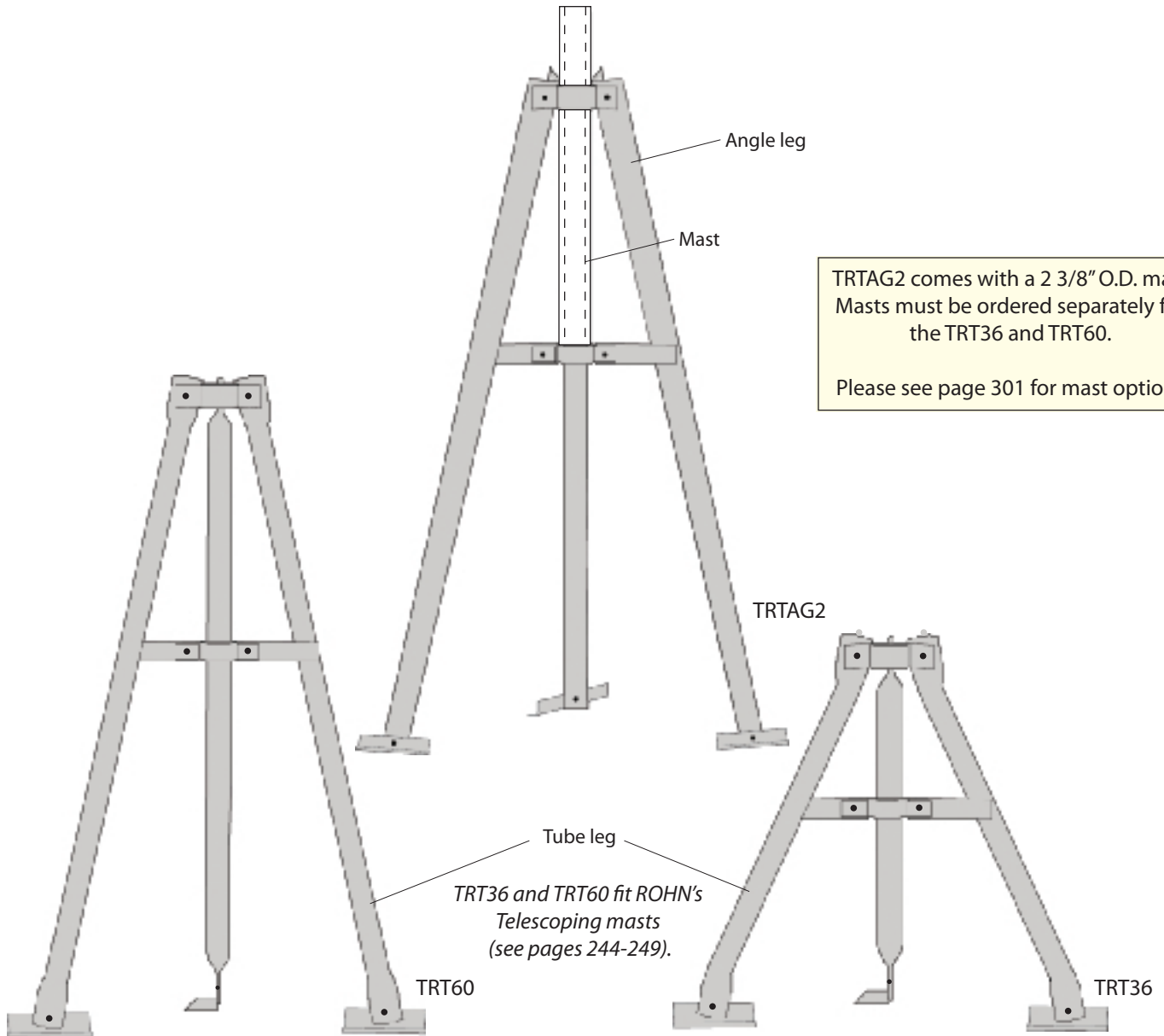

SPECIFICATIONS

Part No.	Description
TRT36	3' tall, tube legs (PG)
TRT60	5' tall, tube legs (PG)
TRTAG2	5' tall, angle legs (HDG) with 2.38" O.D. x 0.154" wall x 3.5' long mast (HDG)

PG = Pre-galvanized
HDG = Hot-dip galvanized

NOTES

WALL MOUNTS



1LG

The Universal One-Legged Mount (1LG) may be the one and only mount that can be installed on any part of any building. This mount is designed for many types of antennas – home, TV, MMDS, DBS and more. The mount has a 1-1/4" O.D. mounting pipe and includes (4) 1/4" dia. x 2" long lag screws for installation. The mount is galvanized for corrosion protection and goes together quickly. The mount is easily shipped via UPS.

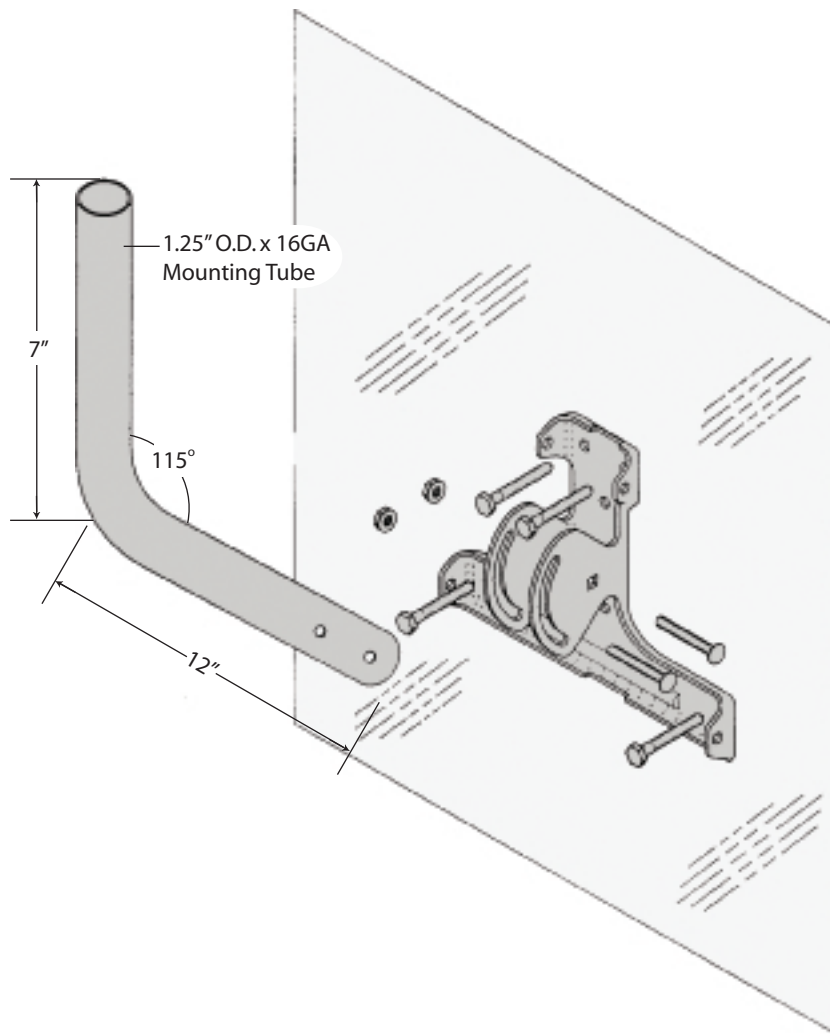

P W M

The ROHN Pole Wall Mount (PWM) is designed to support most Satellite, PCS, Cellular, and Microwave antennas. The PWM allows you to vary the mounting pipe length and diameter, accepting 2 7/8" O.D. - 5" O.D. mounting tubes. The PWM is hot-dip galvanized after fabrication for corrosion protection, and can easily be shipped UPS.

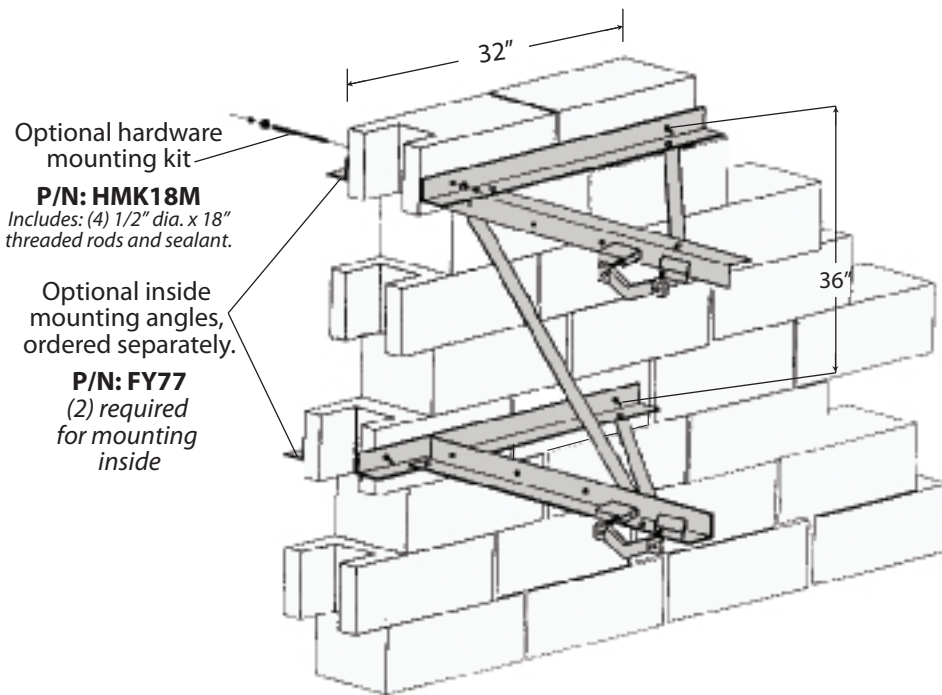

Adjustable mast offset from wall at 16", 22" and 28"

WM 4

The WM4 mount provides 3" clearance to the wall. The WM4 is hot-dip galvanized for corrosion protection. Masts are held in place with a unique "Anti-Twist" locking clamp. This mount includes (4) 1/4" dia. x 2" long lag screws for mounting.

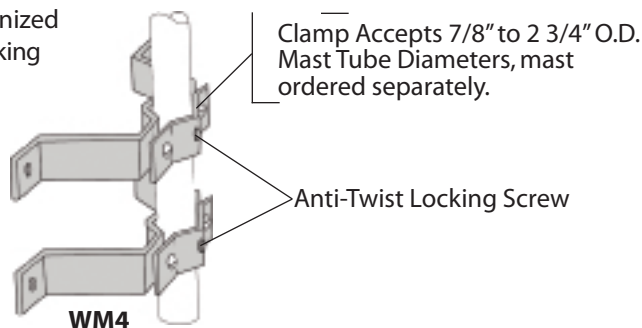

WM 2 1 2

The WM212 mount provides 12" clearance to the wall. The WM212 is hot-dip galvanized for corrosion protection. Optional WMB12A diagonal is available to provide extra strength. Mount is pre-drilled to accept 1/2" dia. connectors.

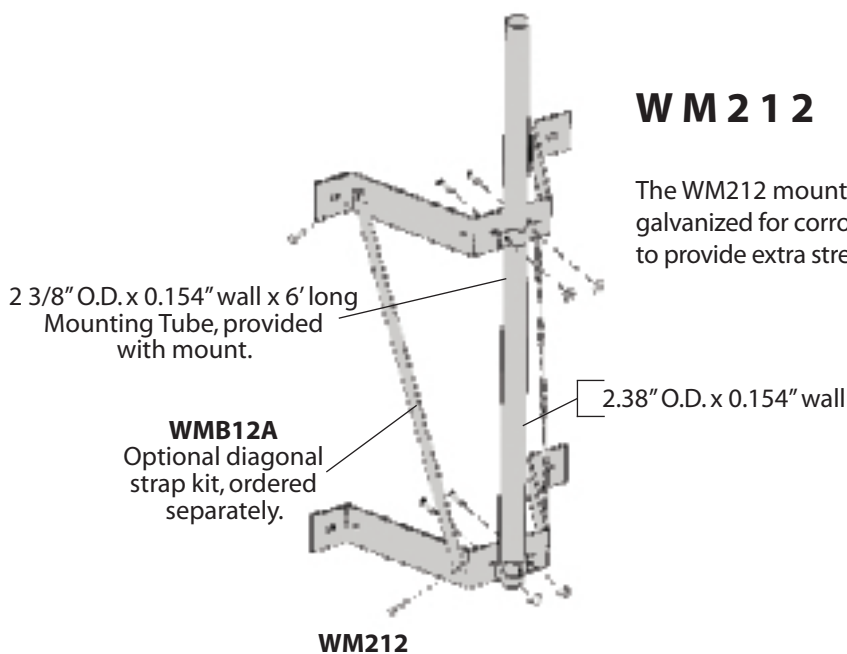

EXTENDED WALL MOUNT ASSEMBLIES

Single and double extended wall mount assemblies can be used on masonry, wood, metal, and other types of walls using up to 1/4" dia. lag screws or bolts. The Wall Mounts are versatile, coming in a variety of stand off lengths and supporting 7/8" to 2 3/4" O.D. masts. The mounts are available as single brackets or double brackets. Masts are held in place with a unique "Anti-Twist" locking clamp. Galvanized for durability, these Wall Mounts are UPS shippable.

Single:	Wall Clearance
WM6S	6" clearance
WM8S	8" clearance
WM12S	12" clearance
WM18S	18" clearance
WM24S	24" clearance
Double:	Wall Clearance
WM8D	8" clearance
WM12D	12" clearance
WM18D	18" clearance
WM24D	24" clearance

NOTE: Connectors to wall not included.

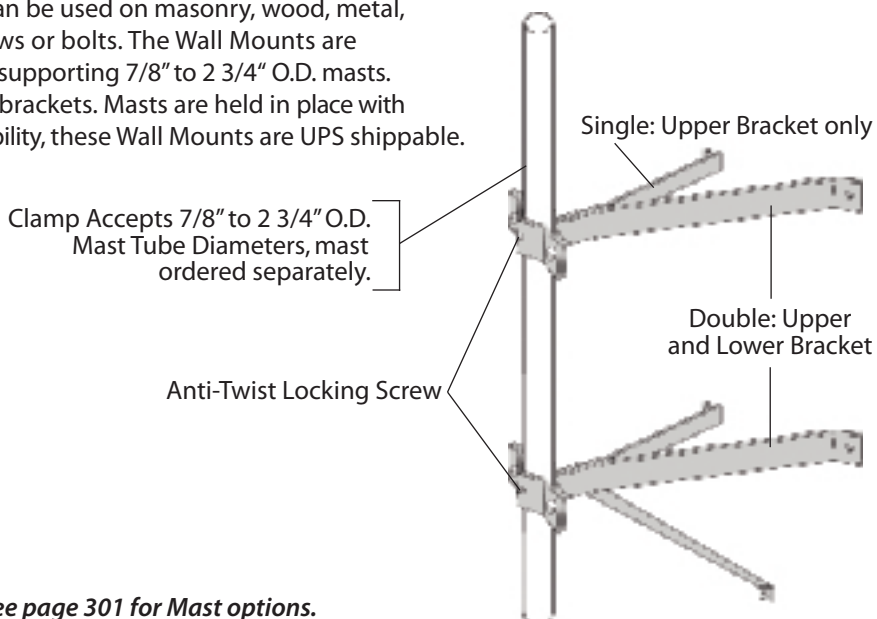

See page 301 for Mast options.

G-SERIES WALL BRACKETS & BASE MOUNTS

The HBUTVRO provides lateral support for 25G, 45G and 55G bracketed towers.

The bracket is pre-drilled to accept 5/8" dia. connectors to wall at 16" or 24" spacing.

Adjustable to position tower 18" - 36" from wall.

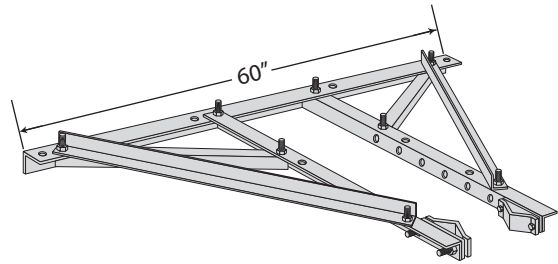

HBUTVRO

25GWM

FOR 25G WALL SUPPORTED TOWERS

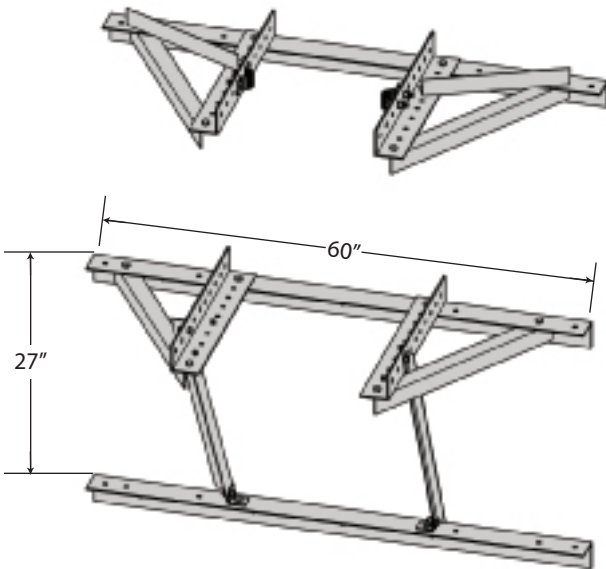

The 25GWM upper bracket provides lateral support for 25G wall supported towers. The lower bracket provides both lateral and vertical support. The 25G base plate (P/N KH6775, not shown) is provided with mount to provide an adjustable 6" - 20" of clearance to wall.

The brackets are pre-drilled to accept 5/8" dia. connectors at 16" or 24" spacing. A minimum 5' separation between the top and bottom brackets is recommended.

The KH1014 bracket provides lateral support for 65G bracketed towers.

The brackets are pre-drilled to accept 3/4" dia. connectors to wall at various center-to-center spacings (4.75" increments).

Adjustable to position tower 18" - 30" from wall.

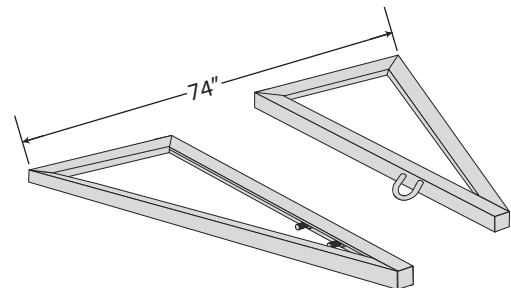

KH1014
FOR 65G BRACKETED TOWERS

All mounts shown are hot-dip galvanized.

NOTES

TOWER MODIFICATION MATERIAL





ROHN MODEL 80 GUYED TOWER

STANDARD GUY BRACKETS FOR 83 & 84 SECTIONS
(2 3/8" & 2 7/8" O.D. LEGS)

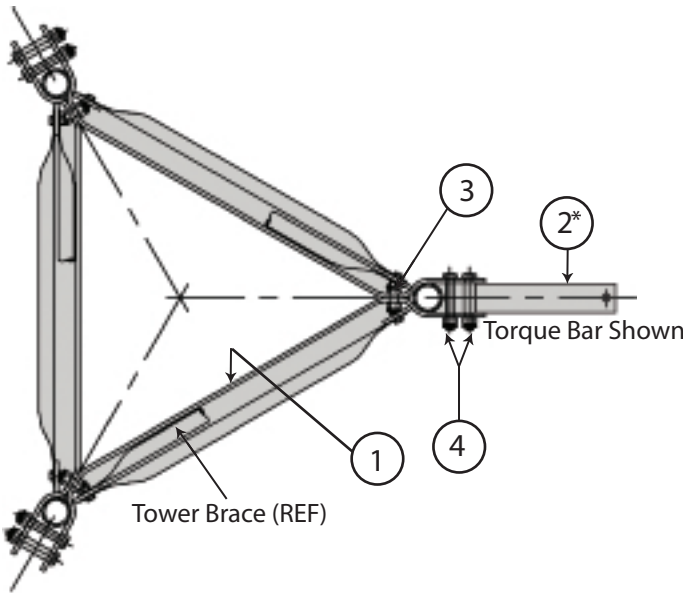

GA80 Bill of Material			
Item	Qty.	Part No.	Description
1	3	KC143	Bar Flat Bracket Guy .38 x 4.5 x 4.5'
2	3	KC145	Bar Flat TA 2.75 x .38 x 1.82'
3	6	210047GA	Bolt Assembly 3/4 x 2 HSB A325
4	9	210058GA	Bolt Assembly 3/4 x 5 HSB A325

These guy brackets are designed for 5/8" EHS maximum guys at 80% guy radius. For use on ROHN Model 80 tower only, supported on brace clips.

For single braced standard sections, guy bracket must be used at the top of the section.

For double braced standard sections, guy brackets may be used at any panel point.

ROHN MODEL 80 GUYED TOWER

STANDARD GUY BRACKETS FOR 85 SECTIONS
(3 1/2" O.D. LEGS)

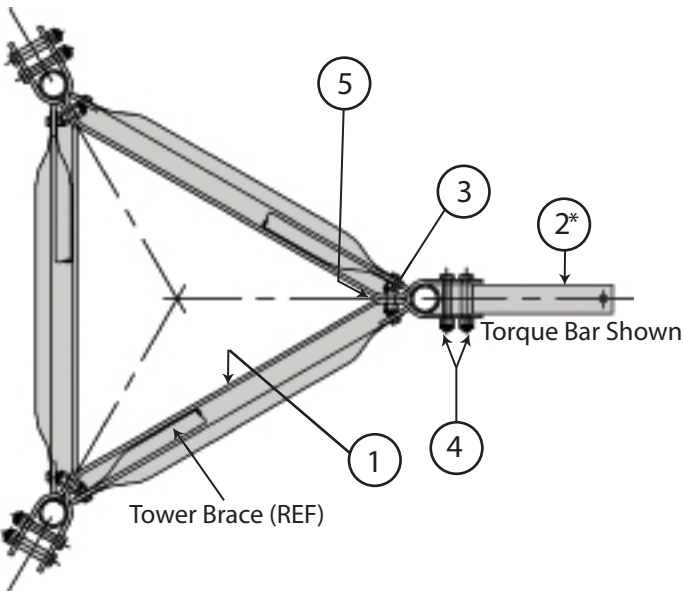

GA85 Bill of Material			
Item	Qty.	Part No.	Description
1	3	KC144	Bar Flat Bracket Guy .38 x 5 x 4.5'
2	3	KC465	Bar Flat TA .38 x 3.5 x 1.83'
3	6	210050GA	Bolt Assembly 3/4 x 2-3/4 HSB A325
4	9	210059GA	Bolt Assembly 3/4 x 5-1/2 HSB A325
5	3	KC441	Spacer Bracket Guy .63 x 3.13 x 4.5"

These guy brackets are designed for 5/8" EHS maximum guys at 80% guy radius. For use on ROHN Model 80 tower only.

For single braced standard sections, guy bracket must be used at the top of the section.

For double braced standard sections, guy brackets may be used at any panel point.

TORQUE ARM

CHANNEL ASSEMBLY FOR 80 TOWERS

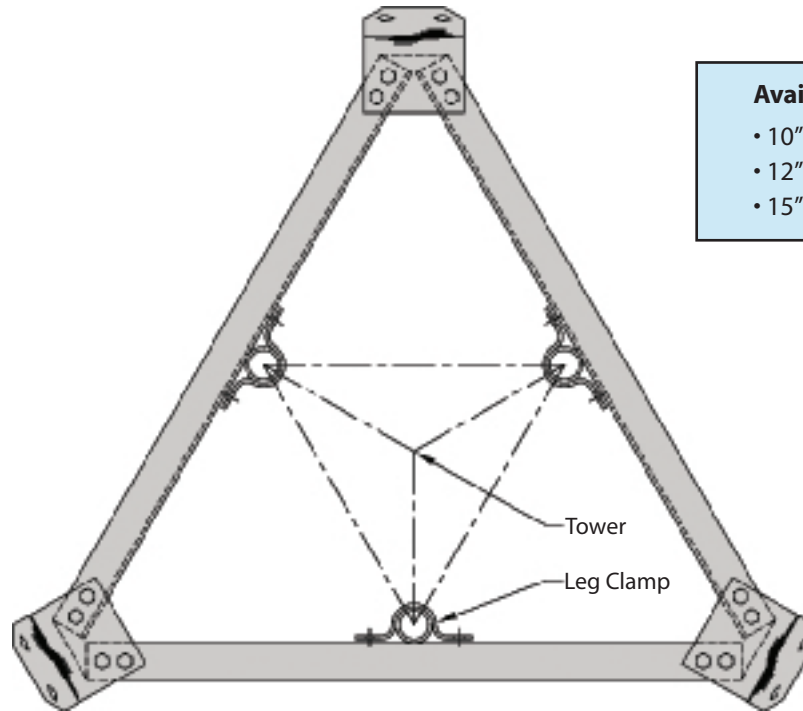

Available Sizes:

- 10" Channel (C10x15.3)
- 12" Channel (C12x20.7)
- 15" Channel (C15x33.9)

To order, provide leg size and desired channel size.

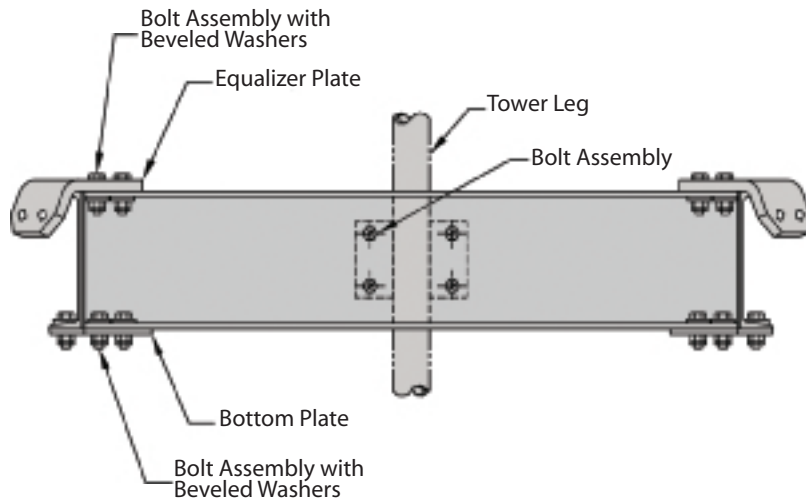

NOTE: For single braced sections, torque arm must bear on brace clips above flange plates. For double braced sections, torque arm must bear on brace clips at any panel point.

REINFORCEMENTS FOR 80 SERIES TOWERS

STANDARD PARTS AVAILABLE FOR TOWER MODIFICATIONS
AND FIELD REINFORCEMENT

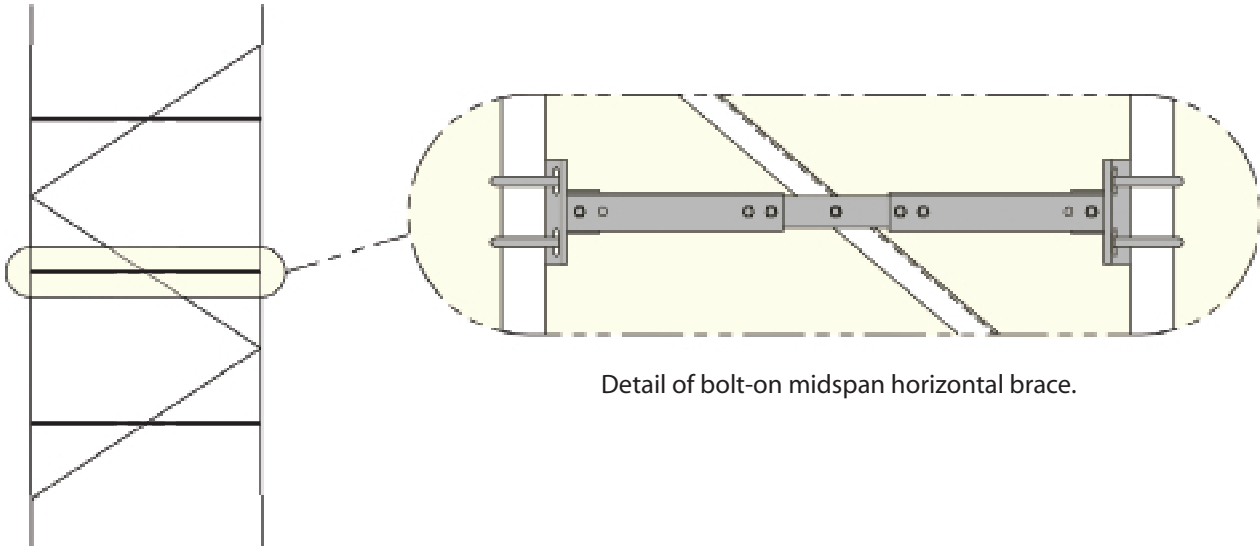

Detail of bolt-on midspan horizontal brace.

To order, provide leg size and size of horizontal desired.

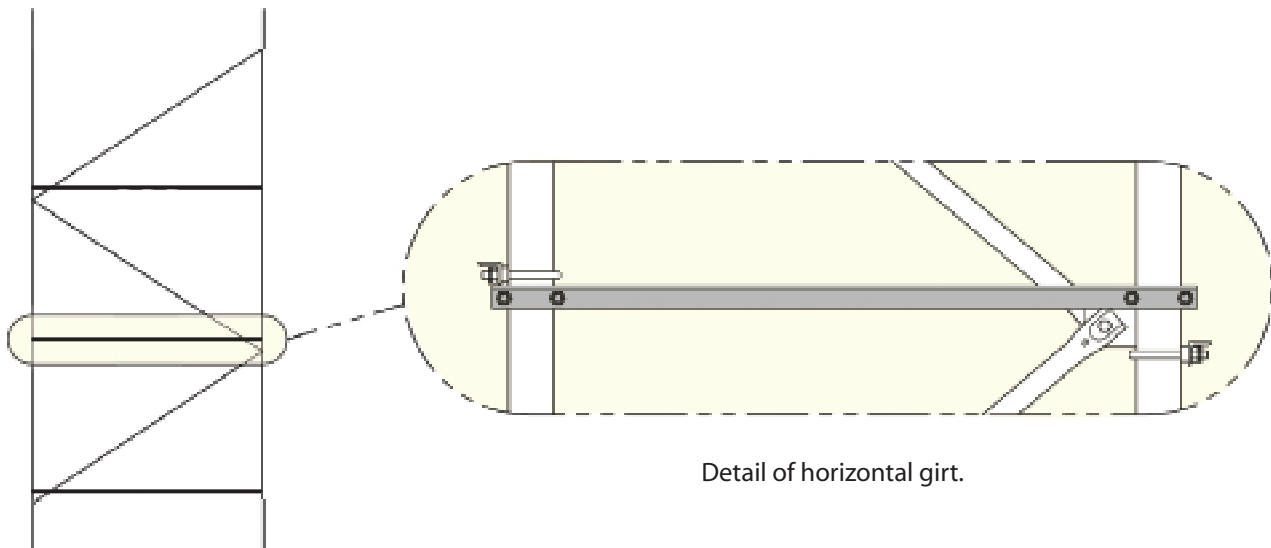

Detail of horizontal girt.

Added braces are shown as a bold line.

REINFORCEMENTS FOR 80 SERIES TOWERS

STANDARD PARTS AVAILABLE FOR TOWER MODIFICATIONS
AND FIELD REINFORCEMENT

Similar reinforcements available for 90 series towers.

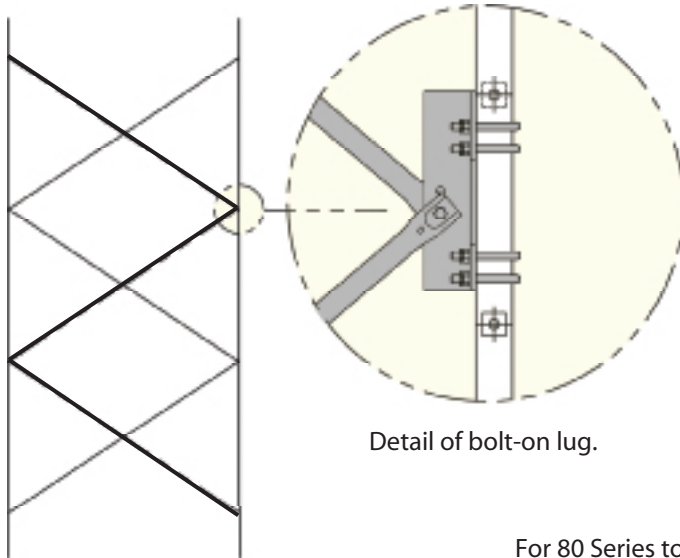

Detail of bolt-on lug.

For 80 Series towers

X-Brace Lug Requirements (Pipe)			
Leg O.D.	Assy. P/N	Lug P/N (1)	U-Bolt Assy. (4)
2.38"	KB497A	KB299	JR83A
Δ 2.38"	KB497ASP	KB299SP	JR84A
* 2.88"	KB498A	KB489	JR84A
** 2.88"	KB498ASP	KB489SP	JR88A
2.88"	KB498ASP1	KB489SP1	JR89A
3.50"	KB499A	KB492	JR88A

X-Brace Lug Requirements (Solid Rod)			
Leg O.D.	Assy. P/N	Lug P/N (1)	U-Bolt Assy. (4)
2.25"	KB565A	KB555	JR83A
2.50"	KB566A	KB556	JR83A
2.75"	KB567A	KB557	JR84A
3.00"	KB568A	KB558	JR84A
3.25"	KB569A	KB559	JR88A

Standard Bracing Available

Light Bracing (16 GA)	
Part No.	Description
KB35R	1.50" Tube, 16GA Diagonal
KB36R	1.50" Tube, 16GA Horizontal
210018GA	1/2 x 1-1/2 A325 Bolt Assy.

Heavy Bracing (11 GA)	
Part No.	Description
KB37R	1.50" Tube, 11GA Diagonal
KB38R	1.50" Tube, 11GA Horizontal
210019GA	1/2 x 1-3/4 A325 Bolt Assy.

- Δ Use w/ 2.88" O.D. X .203" Wall Split Pipe on one side
- * Use w/ 3.50" O.D. X .300" Wall Split Pipe on one side
- ** Use w/ 3.88" O.D. X .500" Wall Split Pipe on one side

Standard and Heavy Duty replacement braces are available. To order heavy duty braces, specify leg size and desired brace size.

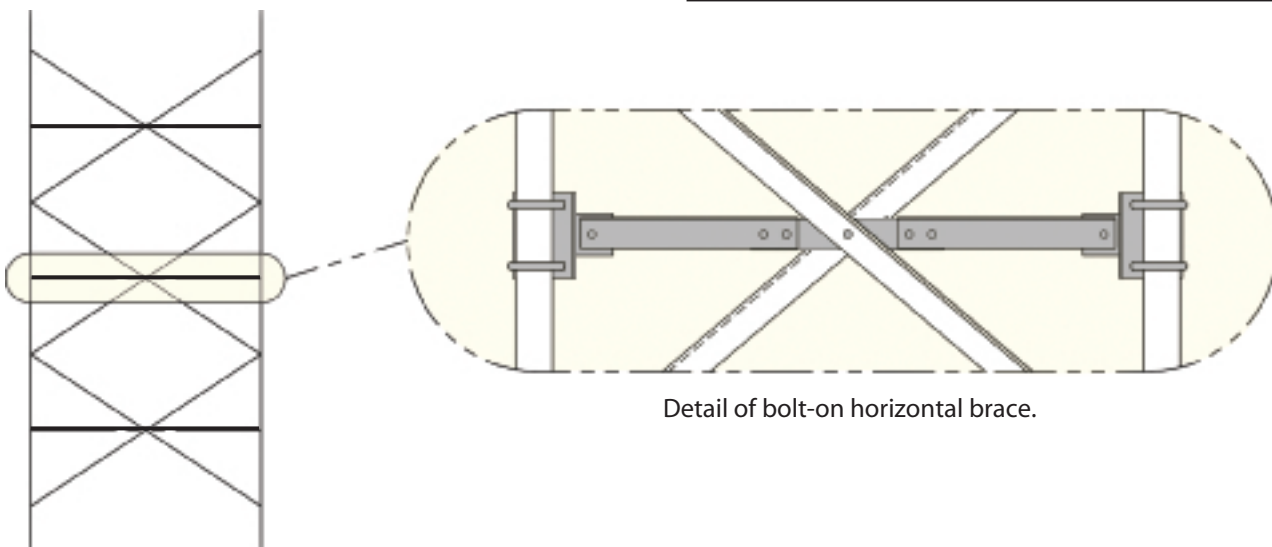

Detail of bolt-on horizontal brace.

Added braces are shown as a bold line.

SELF-SUPPORTING REINFORCEMENTS
 STANDARD PARTS AVAILABLE FOR TOWER MODIFICATIONS
 AND FIELD REINFORCEMENT

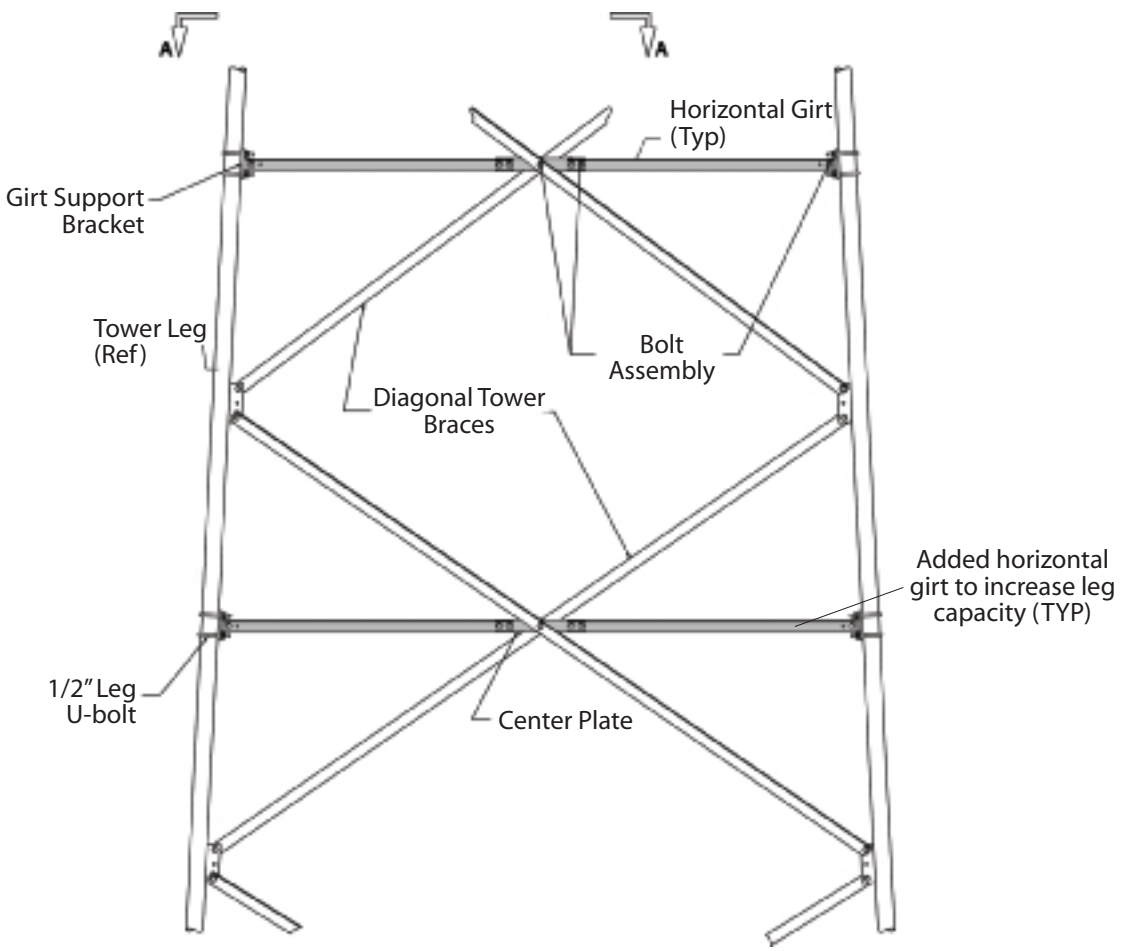

Bolt on brackets are available for all SSV towers.

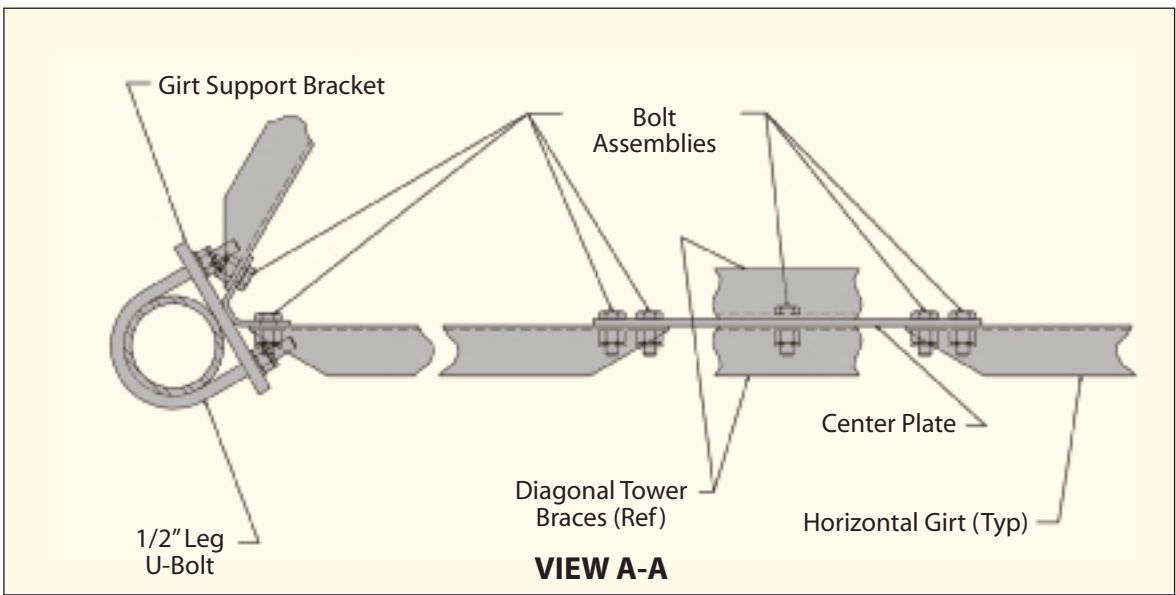

SSMW SELF-SUPPORTING REINFORCEMENTS

STANDARD PARTS AVAILABLE FOR TOWER MODIFICATIONS
AND FIELD REINFORCEMENT

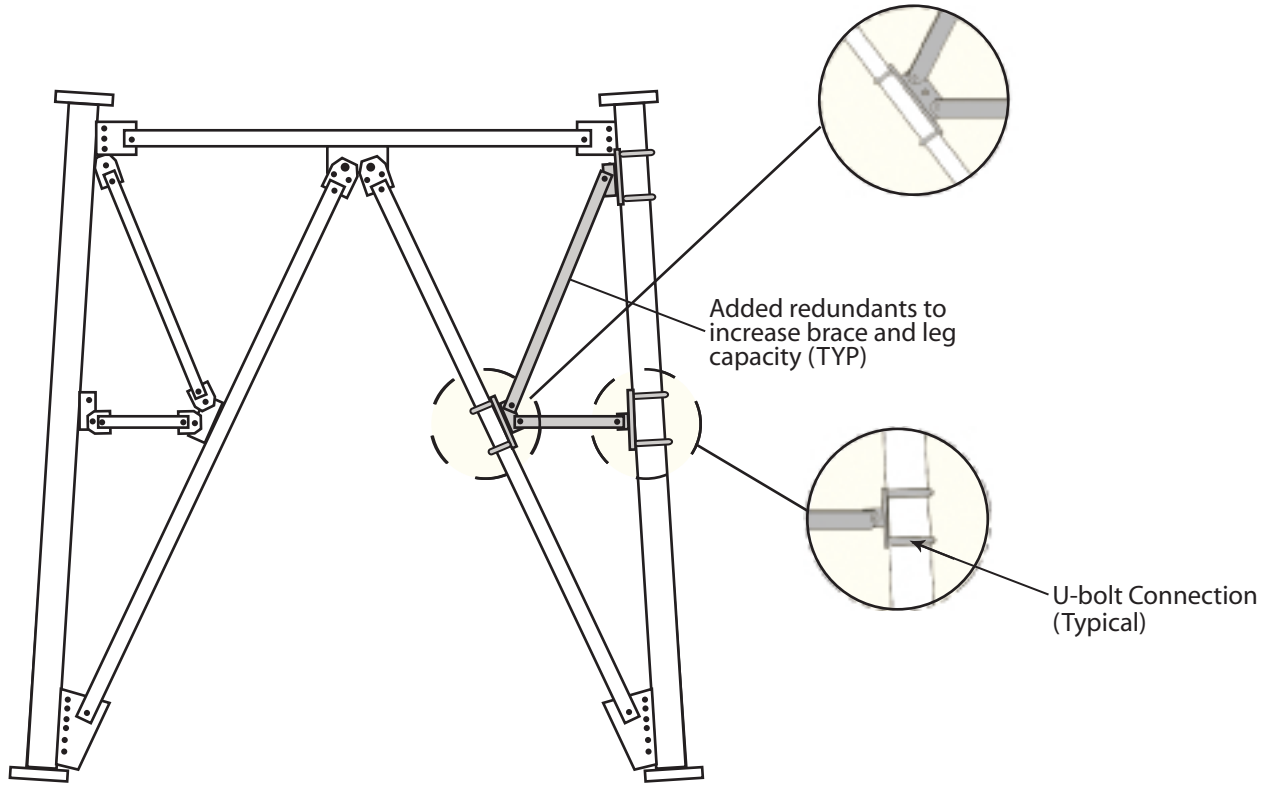

Bolt-on brackets are available for all SSMW legs and internal braces.

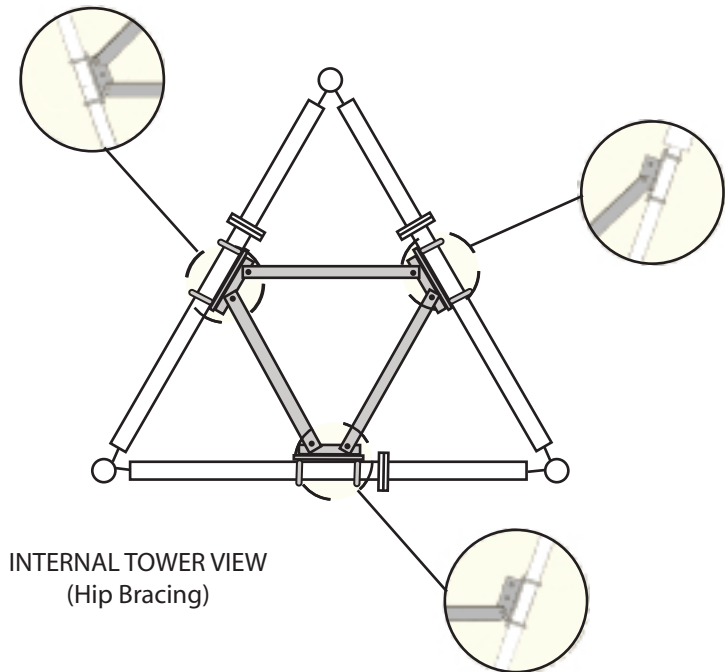



GUY ANCHOR SELECTION CHART

GUYS		TURNBUCKLES		ANCHOR RODS COMPATIBLE WITH TURNBUCKLE SIZE						
SIZE & TYPE	ULTIMATE STRENGTH (LBS)	SIZE	ULTIMATE STRENGTH (LBS)							
3/16EHS	3990	3/8	6000		GAC					
1/4EHS	6650	1/2	11000	GAR	GAC	GAC34				
5/16EHS	11200	5/8	17500	GAR	GAC	GAC34	GAC56			
3/8EHS	15400	5/8	17500	GAR		GAC34	GAC56			
7/16EHS	20800	3/4	26000	GAR		GAC34	GAC56	GAC57		
1/2EHS	26900	7/8	36000				GAC56	GAC57		
9/16EHS	35000	7/8	36000				GAC56	GAC57		
5/8EHS	42400	1	50000					GAC57	GAC58	GAC59
3/4EHS	58300	1-1/4	76000						GAC58	GAC59

ANCHOR RODS

Type	L	A	B	C	D	T	Part No.	Weight (lbs.)
GAR	84"	1"	-	2"	5/8"	-	GAR30	9
GAC	84"	2"	-	1"	5/8"	3/16"	GAC303	13
GAC	84"	2"	-	1"	5/8"	3/16"	GAC305	14
GAC34	84"	2"	12"	1"	3/4"	3/8"	GAC3455TOP	25
GAC56	120"	2-1/2"	12"	1-1/4"	1-1/4"	1/2"	GAC5655TOP	65
GAC57	168"	3"	12"	1-3/8"	1-7/16"	3/4"	GAC5755TOP	125
GAC58	192"	4"	12"	1-3/4"	1-1/4"	1"	GAC5855TOP	220
GAC59	240"	4"	18"	1-3/4"	1-7/16"	1"	GAC5955TOP	310

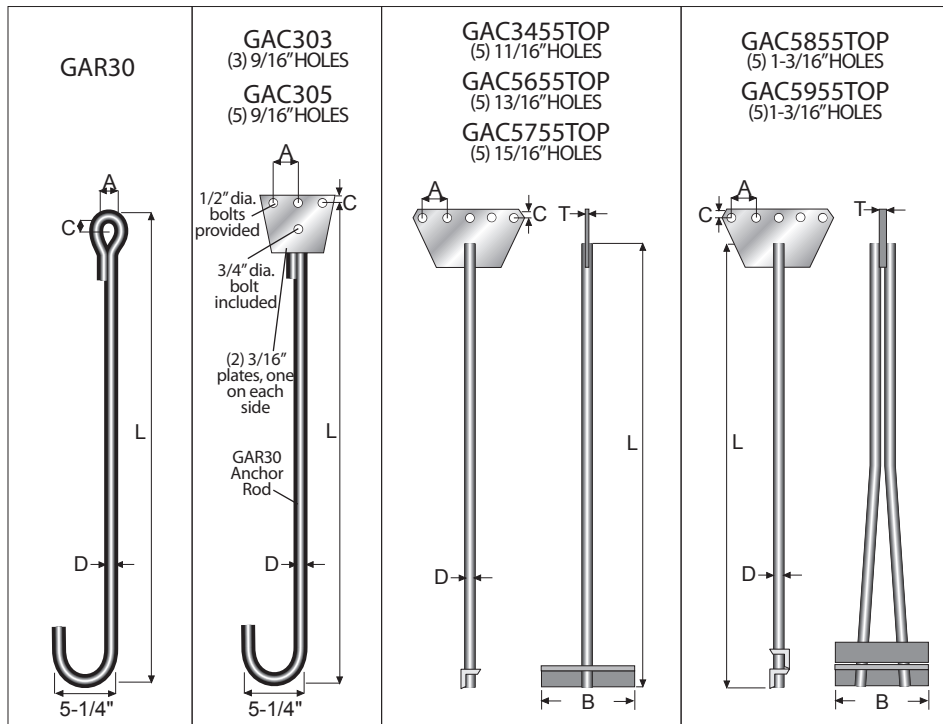

NOTE: GAC Anchors require use of eye and eye turnbuckles. All other anchors are for use with eye and jaw turnbuckles. Refer to page 297.

HARDWARE





NUTS, BOLTS & WASHERS

GRADE 5 BOLT ASSEMBLIES, GALVANIZED [HEX BOLTS, NUT & LOCKING DEVICE]

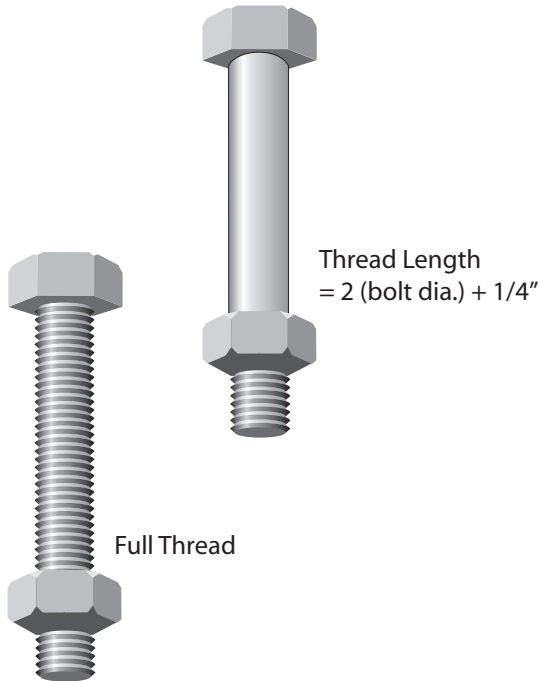

Dia. x Length (inches)	Assembly Part No.	Weight (lbs./100pcs)
5/16 x 2-3/8	210003GA	7/100
3/8 x 1-1/4	210005GA	10/100
3/8 x 1-1/2	210008GA	10/100
3/8 x 2	210009GA	12/100
3/8 x 2-1/2	210011GA	13/100
3/8 x 2-1/2 (Full Thread)	210176GA	13/100
3/8 x 4	210014GA	18/100
3/8 x 4 (Full Thread)	210013GA	18/100
7/16 x 2-1/2	210016GA	17/100
5/8 x 1-3/4	210146GA	35/100
5/8 x 2	210140GA	38/100
5/8 x 3-1/4	210036GA	51/100
5/8 x 3-3/4	210038GA	53/100
3/4 x 4-1/2	210091GA	91/100
7/8 x 3	210062GA	103/100

Pal nuts included with assembly P/N shown.
See table below for other nut locking devices.

NUT LOCKING DEVICE OPTIONS [ADD SUFFIX AFTER BOLT ASSEMBLY PART NUMBER]

Suffix	Nut Locking Device
-	Pal Nut
AN	Anco Nut
TLN	Tri-Loc Nut
LW	Split Ring Washer

Example:

For 3/8" x 1-1/2" bolt assembly with a split ring lock washer used for a nut locking device, in place of a pal nut, order part number: **210011GALW**

NOTE: To order bolts or other hardware in this catalog without nuts and nut locking devices, remove the "A" from the end of the assembly part number.

NUTS, BOLTS & WASHERS

STRUCTURAL BOLT ASSEMBLIES, 120 KSI TENSILE STRENGTH, GALVANIZED
[HEAVY HEX BOLTS, NUTS & NUT LOCKING DEVICE]

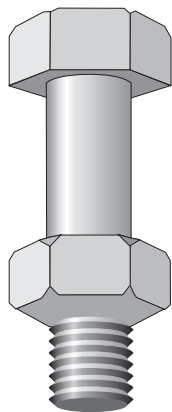

THREAD LENGTHS

Bolt Diameter	Thread Length (inches)
1/2"	1
5/8"	1.25
3/4"	1.38
7/8"	1.5
1"	1.75
1-1/8"	2
1-1/4"	2
1-3/8"	2.25
1-1/2"	2.25

Dia. x Length (inches)	Assy. Part No.	Weight (lbs./100pcs)
1/2 x 1-1/4	210017GA	21/100
1/2 x 1-1/2	210018GA	22/100
1/2 x 1-3/4	210019GA	24/100
1/2 x 2	210020GA	25/100
5/8 x 1-1/2	210029GA	34/100
5/8 x 1-3/4	210030GA	36/100
5/8 x 2	210031GA	68/100
5/8 x 2-1/4	210032GA	42/100
5/8 x 2-1/2	210033GA	43/100
5/8 x 3-1/4	210072GA	45/100
3/4 x 1-3/4	210046GA	58/100
3/4 x 2	210047GA	61/100
3/4 x 2-1/4	210048GA	62/100
3/4 x 2-1/2	210048GA	66/100
3/4 x 2-3/4	210050GA	70/100
3/4 x 4-1/2	210057GA	91/100
3/4 x 5	210058GA	94/100
3/4 x 5-1/2	210059GA	104/100
7/8 x 2-1/4	210061GA	94/100
7/8 x 3-1/2	210063GA	113/100
1 x 4-1/4	210069GA	172/100
1 x 5-1/2	210070GA	197/100
1 x 6	210164GA	204/100

Pal nuts included with assembly P/N shown.
Add suffix from page 288 for other nut locking device.

U-BOLTS, SQUARE BEND, GALVANIZED

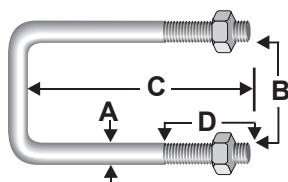

Dimensions (inches)				Assy. Part No.	Weight (lbs./100pcs)
A	B	C	D		
1/2	3-1/4	4-3/8	1-1/4	JR811A	73/100
1/2	4-1/4	5-5/16	1-1/4	JR812A	87/100
1/2	4-1/4	5-13/16	1-3/4	JR812LA	91/100
1/2	6-1/4	7-13/16	1-3/4	JR815A	119/100
3/4	6-1/4	8-1/2	2-1/2	JR12685SQA	277/100

Pal nuts included with assembly P/N shown.
Add suffix from page 288 for other nut locking device.



NUTS, BOLTS & WASHERS

U-BOLTS, ROUND BEND, GALVANIZED

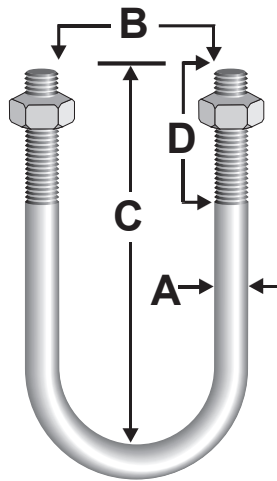

Dimensions (inches)				Assy. Part No.	Weight (lbs./100pcs)
A	B	C	D		
1/4	1-1/4	2-1/4	1-3/8	JR45GA	12/100
5/16	1-1/2	2-5/8	1-1/4	JR51A	15/100
5/16	1-1/2	2	1-1/4	JR55A	14/100
5/16	1-11/6	2-1/4	1	JR54A	15/100
3/8	13/16	1-5/8	7/8	JR69A	21/100
3/8	1	2-1/4	1-1/4	JR67A	23/100
3/8	1-1/4	2-3/4	1-5/8	JR66A	31/100
3/8	1-1/2	3	1-3/4	JR65A	29/100
3/8	2-1/8	3	1-1/4	JR68A	31/100
3/8	2-1/2	4	2	JR60A	35/100
3/8	2-1/2	3-1/2	1-1/2	JR61A	33/100
3/8	3-1/2	4-5/8	1-5/8	JR64A	41/100
3/8	4	6	2-1/4	JR62A	42/100
3/8	4-1/2	6-1/2	2-1/4	JR63A	52/100
1/2	3/4	3-1/2	2-1/2	JR81A	60/100
1/2	2	3-3/4	1-3/4	JR810A	63/100
1/2	2-1/4	4-1/2	2-1/4	JR82A	71/100
1/2	2-1/2	4-1/2	2-1/2	JR83A	71/100
1/2	3	5-5/8	3	JR84A	84/100
1/2	3	4-1/8	1-1/2	JR84SA	73/100
1/2	3-1/2	6	3	JR88A	88/100
1/2	4	6-1/2	3-1/2	JR89A	98/100
1/2	4-1/2	6	2-1/4	JR85A	91/100
1/2	5-5/8	8	3-1/4	JR86A	114/100
1/2	6-3/4	9	3-1/4	JR87A	127/100
1/2	8-3/4	11-1/8	2-1/2	JR90SA	188/100
1/2	10-7/8	13	2-1/2	JR110A	198/100
1/2	12-7/8	15	2-1/2	JR120A	243/100
3/4	3	5-3/4	3	JR121A	199/100
3/4	3-1/2	6-1/4	2-3/4	JR122A	263/100
3/4	4	6-3/4	2-1/2	JR123A	284/100
3/4	4-1/2	7-1/4	2-1/2	JR124A	280/100
3/4	5-5/8	8-5/16	2-1/2	JR125A	318/100
3/4	6-3/4	10	3-1/2	JR126STA	390/100
3/4	8-3/4	11-3/8	2-1/2	JR128A	424/100
3/4	10-7/8	13-3/8	2-5/8	JR1210A	517/100
3/4	12-3/4	15	2-1/2	JR1212A	591/100

Pal nuts included with assembly P/N shown.
Add suffix from page 288 for other nut locking device.

NUTS, BOLTS & WASHERS

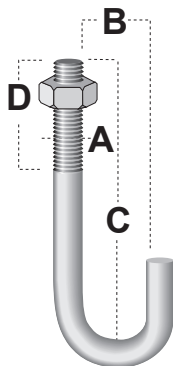

J-BOLTS, GALVANIZED

Dimensions (inches)				Assy. Part No.	Weight (lbs./100pcs)
A	B	C	D		
3/8	5/8	4	2-5/8	J44AA	16/100
3/8	5/8	5-11/16	2-3/4	J51A	23/100
3/8	5/8	7-9/16	5-1/2	J170A	35/100
3/8	3/4	2	1-1/2	J167A	10/100

Pal nuts included with assembly P/N shown.
Add suffix from page 288 for other nut locking device.

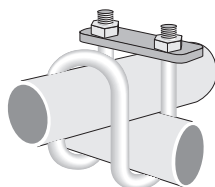

U-BOLTS, DOUBLE BEND, GALVANIZED

Description	Assy. Part No.	Weight (lbs./100pcs)
5/16" dia. (18 THD) For 1-1/4" Tubing	TB5125BA	54/100

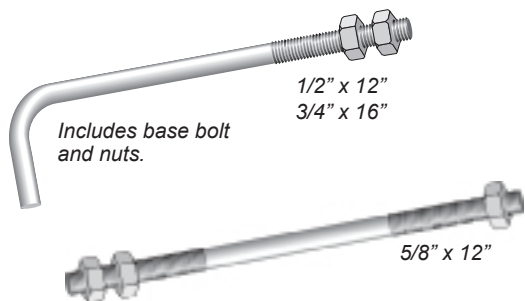

BASE BOLT, GALVANIZED

Description	Part No.	Weight (lbs.)
1/2" x 12" + 2" (Hook)	1/2X12BB	1/2 ea.
5/8" x 12"	260145G	1 ea.
3/4" x 16" + 3" (Hook)	3/4X16BB	1-1/2 ea.



STEP BOLT, GALVANIZED

Description	Part No.	Weight (lbs./100pcs)
5/8" x 7" (2-1/2" THD Length)	210042G	84/100
5/8" x 7" (2-1/2" THD Length) With 2 Heavy Hex Nuts	5/8STEP	108/100

NUTS, BOLTS & WASHERS

Plain Nut

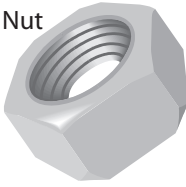

Pal Nut
(used with plain nut)



Tri-Loc Nut



Anco Nut



HEAVY HEX NUT OPTIONS, GALVANIZED

Description	Plain Nut	Weight (lbs./100pcs)	Pal Nut P/N	Weight (lbs./100pcs)	Tri-Loc P/N	Weight (lbs./100pcs)	Anco P/N	Weight (lbs./100pcs)
3/8" - 16	230005	3/100	110159	0.4/100	38CTLFG/2H	3/100	230008	3/100
1/2" - 13	110143	7/100	110160	1/100	50CTLFG/2H	7/100	110581	7/100
5/8" - 11	110146	12/100	110161	1/100	58CTLFG/2H	12/100	110510	12/100
3/4" - 10	230020	19/100	110162	2/100	75CTLFG/2H	19/100	110511	19/100
7/8" - 9	110149	30/100	110163	2/100	78CTLFG/2H	30/100	110512	30/100
1" - 8	110150	43/100	110164	4/100	1CTLFG/2H	43/100	110513	43/100

HARDENED FLAT WASHERS, GALVANIZED

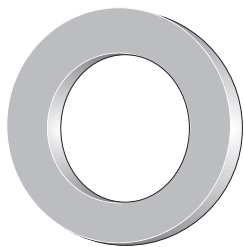

Plain Washer

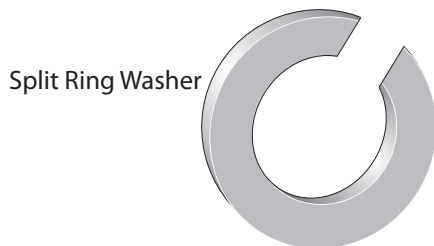

Split Ring Washer

Description	Plain Washer	Weight (lbs./100pcs)	Split Ring Washer	Weight (lbs./100pcs)
3/8"	110950	1/100	250082	1/100
1/2"	110202	2/100	250083	2/100
5/8"	110205	3/100	250084	3/100
3/4"	110208	5/100	250042	5/100
7/8"	110210	6/100	250046	10/100
1"	110214	8/100	250047	10/100

NUTS, BOLTS & WASHERS

BEVELED WASHERS, GALVANIZED

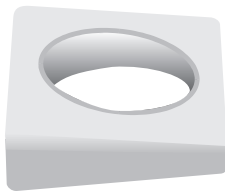

Description	Part No.	Weight (lbs./100pcs.)
3/8"	110398	7/100
1/2"	110399	7/100
5/8"	110400	15/100
3/4"	110551	14/100
7/8"	250062G	31/100
1"	110686	28/100

ROHN GUY MATERIALS

THIMBLES, GALVANIZED



Description	Assy. Part No.	Weight (lbs./100pcs.)
1/4" Standard thimble, open for 1/8" to 3/16" guys	1/4TH	4/100
5/16" Heavy duty thimble, open for 3/16" guys	5/16THH	12/100
3/8" Heavy duty thimble, open for 1/4" guys	3/8THH	25/100
7/16" Heavy duty thimble, open for 5/16" guys	7/16THH	30/100
1/2" Heavy duty thimble, open for 3/8" guys	1/2THH	51/100
9/16" Heavy duty thimble, open for 7/16" guys	9/16THH	51/100
5/8" Heavy duty thimble, open for 1/2" or 9/16" guys	5/8THH	75/100
3/4" Heavy duty thimble, open for 5/8" guys	3/4THH	147/100
7/8" Heavy duty thimble, open for 3/4" guys	7/8THH	175/100
1" Heavy duty thimble, open for 7/8" guys	1THH	275/100



ROHN GUY MATERIALS

CABLE CLAMPS, FORGED, GALVANIZED



Description	Part No.	Weight (lbs./100pcs.)
3/16" Cable Clamp, Forged	140214	10/100
1/4" Cable Clamp, Forged	140001	20/100
5/16" Cable Clamp, Forged	140002	30/100
3/8" Cable Clamp, Forged	140003	47/100

NUT & PIN TYPE SHACKLES, HEAT TREATED, GALVANIZED



Description	Part No.	Weight (lbs./100pcs.)
3/8" (13,200 lbs. ultimate strength)	3/8S	25/100
1/2" (26,400 lbs. ultimate strength)	1/2S	70/100
5/8" (42,000 lbs. ultimate strength)	5/8S	150/100
3/4" (67,700 lbs. ultimate strength)	3/4S	232/100
7/8" (85,800 lbs. ultimate strength)	7/8S	340/100
1" (112,200 lbs. ultimate strength)	1S	500/100
1-1/8" (125,400 lbs. ultimate strength)	1-1/8S	700/100
1-1/4" (158,400 lbs. ultimate strength)	1-1/4S	975/100

BIG GRIP END SLEEVES, GALVANIZED

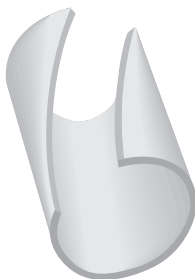

Description	Part No.	Weight (lbs./100pcs.)
3/16"	GC65303	3/100
1/4"	GC65136	3/100
5/16"	GG65128	3/100
3/8"	GC65264	5/100
7/16"	GC65265	7/100
1/2"	GC65266	10/100
9/16"	GC65267	11/100
5/8"	GC65268	14/100
3/4"	GC65269	21/100
7/8"	GC65270	27/100
1"	GC65271	32/100

NOTES:

1. Oversized heavy duty thimbles must be used with all Big-Grips.

ROHN GUY MATERIALS

BIG-GRIPS, GALVANIZED
[BIG-GRIP WITH END SLEEVE]

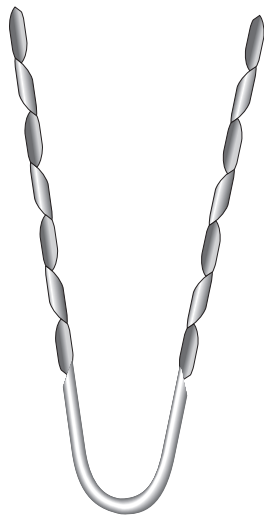

Description	Part No.	Weight (lbs./100pcs.)
3/16"	BG2142	33/100
1/4"	BG2144	50/100
5/16"	BG2146	82/100
3/8"	BG2147	112/100
7/16"	BG2148	188/100
1/2"	BG2115	315/100
9/16"	BG2116	480/100
5/8"	BG2111	650/100
3/4"	BG2112	1080/100
7/8"	BGMS7023	1125/100

TURNBUCKLES, HEAT-TREATED, GALVANIZED

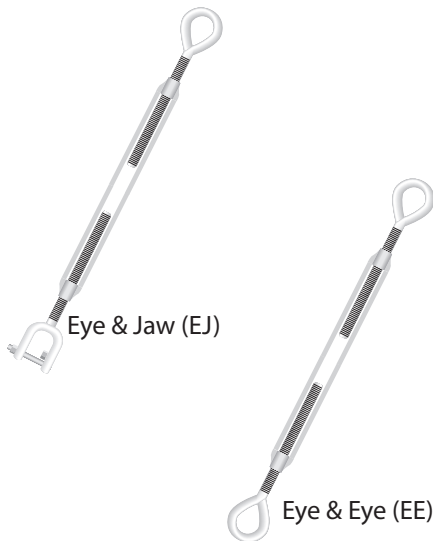

Eye & Jaw (EJ)

Eye & Eye (EE)

Thread Diameter x Take Up	Type	Part No.	Weights (lbs.)
3/8" x 6" (6,000 lbs. ultimate strength)	EE	3/8TBE&E	1
3/8" x 6" (6,000 lbs. ultimate strength)	EJ	3/8TBE&J	1
1/2" x 12" (11,000 lbs. ultimate strength)	EE	1/2TBE&E	2
1/2" x 12" (11,000 lbs. ultimate strength)	EJ	1/2TBE&J	2
5/8" x 12" (17,500 lbs. ultimate strength)	EJ	5/8TBE&J	4
3/4" x 12" (26,000 lbs. ultimate strength)	EJ	3/4TBE&J	5
7/8" x 12" (36,000 lbs. ultimate strength)	EJ	7/8TBE&J	8
1" x 12" (50,000 lbs. ultimate strength)	EJ	1TBE&J	11
1-1/4" x 18" (76,000 lbs. ultimate strength)	EJ	11/4X18TB	24
1-1/2" x 18" (107,000 lbs. ultimate strength)	EJ	11/2X18TB	35
1-3/4" x 18" (140,000 lbs. ultimate strength)	EJ	13/4X18TB	54

EYE BOLT, GALVANIZED



Description	Part No.	Weight (lbs.)
5/8" x 18" Eye Bolt with Nuts	260004P	2

SCREW ANCHOR, GALVANIZED

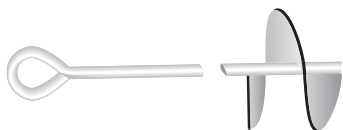

Description	Part No.	Weight (lbs.)
1/2" dia. x 30" long (4" auger)	GAS4303	7
5/8" dia. x 48" long (6" auger)	GAS604	7

ROHN GUY MATERIALS



GUYS, GALVANIZED

Description	Part No.	Weight (lbs.)
6 Strand, 18GA - 1,000' coil (610 lbs. ultimate strength)	618	42
3/16" - 500' coil (3,990 lbs. ultimate strength)	3/16EHS500	36
3/16" - 1,000' coil (3,990 lbs. ultimate strength)	3/16EHS1000	73
3/16" - cut length* (3,990 lbs. ultimate strength)	3/16EHS	73/MFT
1/4" - 500' coil (6,650 lbs. ultimate strength)	1/4EHS500	60
1/4" - 1,000' coil (6,650 lbs. ultimate strength)	1/4EHS1000	120
1/4" - cut length* (6,650 lbs. ultimate strength)	1/4EHS	120/MFT
5/16" - cut length* (11,200 lbs. ultimate strength)	142265	205/MFT
3/8" - cut length* (15,400 lbs. ultimate strength)	142261	279/MFT
7/16" - cut length* (20,800 lbs. ultimate strength)	142260	399/MFT
1/2" - cut length* (26,900 lbs. ultimate strength)	142259	517/MFT
9/16" - cut length* (35,000 lbs. ultimate strength)	142258	671/MFT
5/8" - cut length* (42,400 lbs. ultimate strength)	142264	813/MFT
3/4" - cut length* (58,300 lbs. ultimate strength)	142257	1155/MFT
7/8" - cut length* (79,700 lbs. ultimate strength)	142256	1581/MFT
1" - cut length* (122,000 lbs. ultimate strength)	1BS	2100/MFT

*Please provide desired guy length with order.

MFT = 1,000 FT

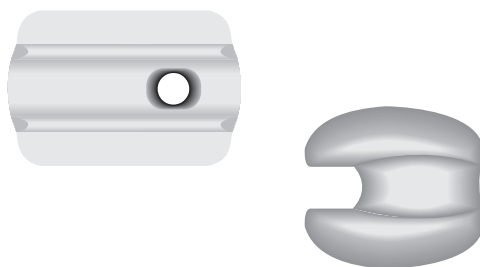

GUY STRAIN INSULATORS, PORCELAIN

Description	Part No.	Weight (lbs.)
10,000 lbs. ultimate strength	502	1
12,000 lbs. ultimate strength	504	1.5
20,000 lbs. ultimate strength	506	3



GRIPPLE GRIP

Description	Part No.
Gripple Grip for 6 strand, 18 GA guy installation	61820GRPL

ROHN REV G GROUNDING

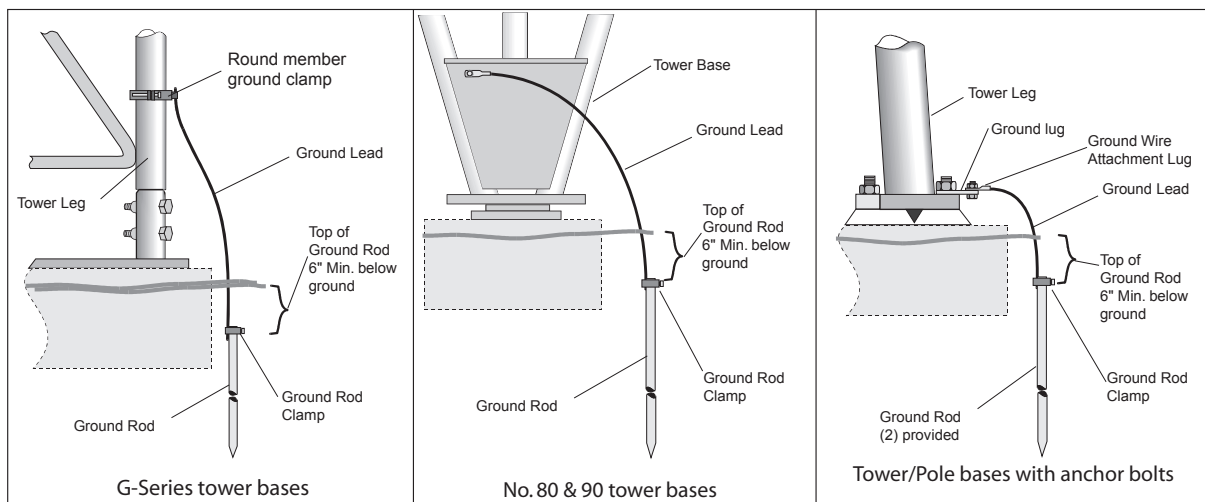

GUY ANCHOR GROUNDING KIT

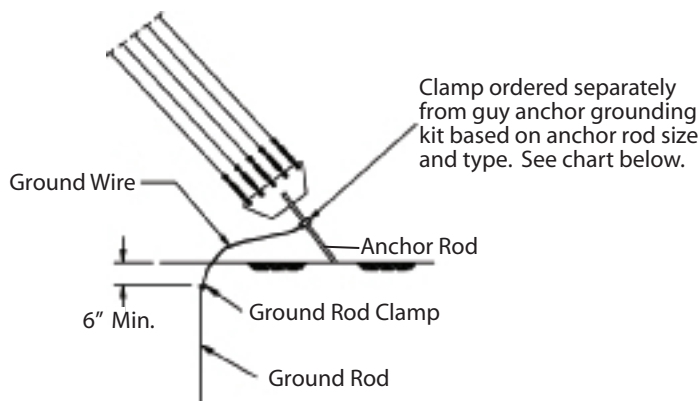

Tower Type	Description	Kit Part No.	No. of Kits Required
Guyed Masts	80 & 90 Tower Base Grounding Kit	BGK1GGX	3 per tower
	55G & 65G Base Grounding Kit	BGK2GGX	3 per tower
	25G & 45G Base Grounding Kit	BGK3GGX	3 per tower
	Guy Anchor Grounding Kit	AGK1GGX	1 per each anchor radius
	Guy Anchor Clamp for 1/2" - 3/4" O.D. Rods	CPC.5/.75	1 per anchor
	Guy Anchor Clamp for 1" - 1-1/4" O.D. Rods	CPC1/1.25	1 per anchor
	Guy Anchor Clamp for 1-1/2" - 2" O.D. Rods	CPC1.5/2	1 per anchor
Self-Supporting Structures	1/2" Anchor Bolt Grounding Kit	BGK4GGX	3 per tower/pole
	5/8" Anchor Bolt Grounding Kit	BGK5GGX	3 per tower/pole
	3/4" Anchor Bolt Grounding Kit	BGK6GGX	3 per tower/pole
	7/8" Anchor Bolt Grounding Kit	BGK7GGX	3 per tower/pole
	1" Anchor Bolt Grounding Kit	BGK8GGX	3 per tower/pole



STEEL TUBING

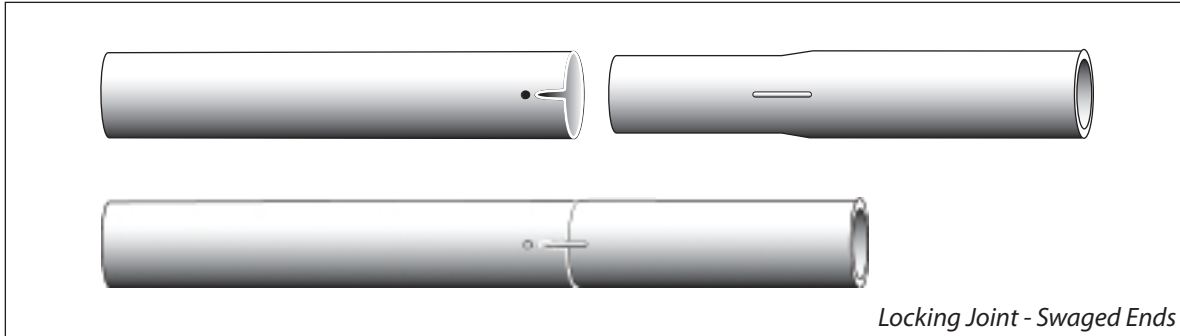

ROHN offers both swaged and expanded 16 GA. tubing, commonly used with our roof and wall mounts.

Swaged - This tubing has a locking joint. When tubing is swaged, the metal is compressed and made thicker so that the joint is stronger than the original material. Swaging also eliminates the "joint bulge" common with expanded tubing.

Expanded - A tube with an expanded end used along with a tube with a plain end.

ROHN tubing is offered in two types of finishes, hot-dip galvanized and pre-galvanized. ROHN's hot-dip galvanized tubing is fabricated from high strength steel, then immersed in molten zinc giving all surfaces, including the interior, an even coating of zinc for maximum corrosion protection. There are no seams, holes or edges left uncoated. Pre-galvanized tubing is made from a coil of steel which is galvanized at the steel mill, cut into strips, and then formed into a piece of tubing. Where the tubing is welded, zinc is sprayed over the weld to give it protection. It has a slightly uncoated seam on the inside and ends.

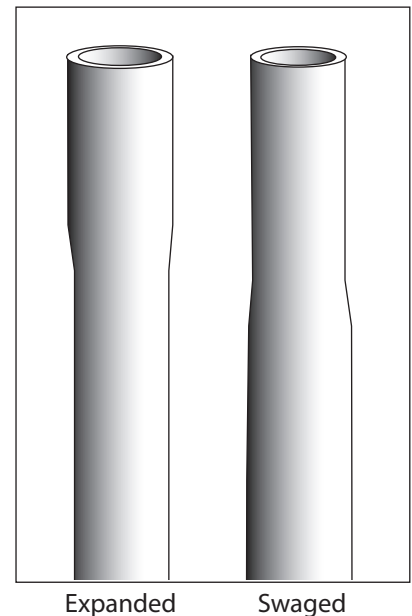

TUBING SPECIFICATIONS

Tubing Part No.	End Type	Description	Finish
160505GHS	Swaged	1-1/4" O.D. x 16 GA. x 5' long	Hot-Dip Galvanized
160505PHS	Swaged	1-1/4" O.D. x 16 GA. x 5' long	Pre-Galvanized
160506PLX	Expanded	1-1/2" O.D. x 16 GA. x 5' long	Pre-Galvanized
161005GHS	Swaged	1-1/4" O.D. x 16 GA. x 10' long	Hot-Dip Galvanized
161005PHS	Swaged	1-1/4" O.D. x 16 GA. x 10' long	Pre-Galvanized

MOUNTING TUBES HOT-DIP GALVANIZED

Standard

Description	Length	Part Number	Weight (lbs.)
2.38" O.D. x 0.154" wall	5'	KH275	20
2.38" O.D. x 0.154" wall	6'	KH1256	24
2.38" O.D. x 0.154" wall	6' 8"	KH281	26
2.38" O.D. x 0.154" wall	8'	KY1304	30
2.38" O.D. x 0.154" wall	10'	KH287	39
2.38" O.D. x 0.154" wall	12'	KH365	47
2.38" O.D. x 0.154" wall	14'	KH2805	55
2.38" O.D. x 0.154" wall	16'	KH2806	62
2.38" O.D. x 0.154" wall	18'	KH2807	70
2.88" O.D. x 0.203" wall	5'	KH276	31
2.88" O.D. x 0.203" wall	6'	KH2576	37
2.88" O.D. x 0.203" wall	6' 8"	KH282	41
2.88" O.D. x 0.203" wall	8'	KH2541	50
2.88" O.D. x 0.203" wall	10'	KH288	62
2.88" O.D. x 0.203" wall	12'	KH366	74
2.88" O.D. x 0.203" wall	14'	KH2802	86
2.88" O.D. x 0.203" wall	16'	KH2803	99
2.88" O.D. x 0.203" wall	18'	KH2804	111
2.88" O.D. x 0.203" wall	20'	KH4813	123
4.50" O.D. x 0.237" wall	5'	KH279	58
4.50" O.D. x 0.237" wall	6' 8"	KH285	77
4.50" O.D. x 0.237" wall	8'	KH2447	92
4.50" O.D. x 0.237" wall	10'	KH291	115
4.50" O.D. x 0.237" wall	12'	KH369	138
4.50" O.D. x 0.237" wall	14'	KH2509	161

Extra Heavy

Description	Length	Part Number	Weight (lbs.)
2.38" O.D. x 0.218" wall	5'	KH1193	27
2.38" O.D. x 0.218" wall	6' - 8"	KH1194	36
2.38" O.D. x 0.218" wall	8'	KH2229	43
2.88" O.D. x 0.276" wall	5'	KH1200	41
2.88" O.D. x 0.276" wall	6' - 8"	KH1201	55
2.88" O.D. x 0.276" wall	8'	KH2987	65
2.88" O.D. x 0.276" wall	10'	KH1202	82
2.88" O.D. x 0.276" wall	12'	KH1203	98
2.88" O.D. x 0.276" wall	14'	KH5768	114
4.50" O.D. x 0.337" wall	5'	KH1221	80
4.50" O.D. x 0.337" wall	6' - 8"	KH1222	106
4.50" O.D. x 0.337" wall	8'	KH1977	127
4.50" O.D. x 0.337" wall	10'	KH1223	159
4.50" O.D. x 0.337" wall	12'	KH1224	191
4.50" O.D. x 0.337" wall	16'	KH3614	254
4.50" O.D. x 0.337" wall	18'	KH5627	286



MISCELLANEOUS



PAINT

Description	Part No.	Weight (lbs.)
Tower Paint, Orange, Acrylic Latex	PNTNPO5	11/gal.
Tower Paint, White, Acrylic Latex	PNTNPW9	11/gal.



COLD GALVANIZE

Description	Part No.	Weight (lbs.)
Cold Galvanize, Spray	380063	1/can
Cold Galvanize, Gallon	380147	1/gal.

TOWER LIGHTING GUIDELINES





FAA STYLE "A" SERIES RED OBSTRUCTION

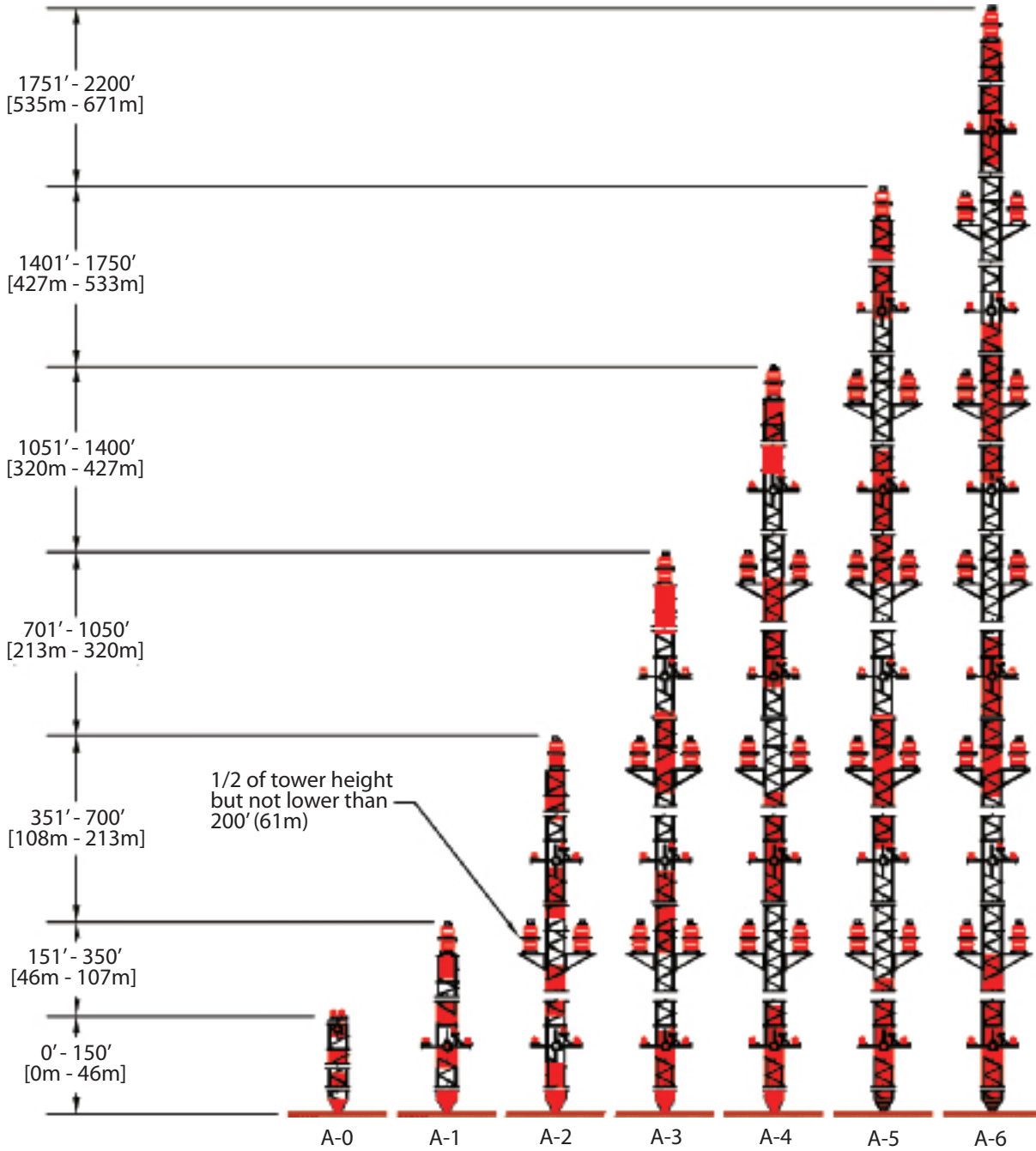

L-864 (Red Beacon)



L-810 (Obstruction Light)

Day Protection = Aviation Orange/White Paint
 Night Protection = 2,000cd Red Beacon and Sidelights



FAA STYLE "B" SERIES HIGH INTENSITY

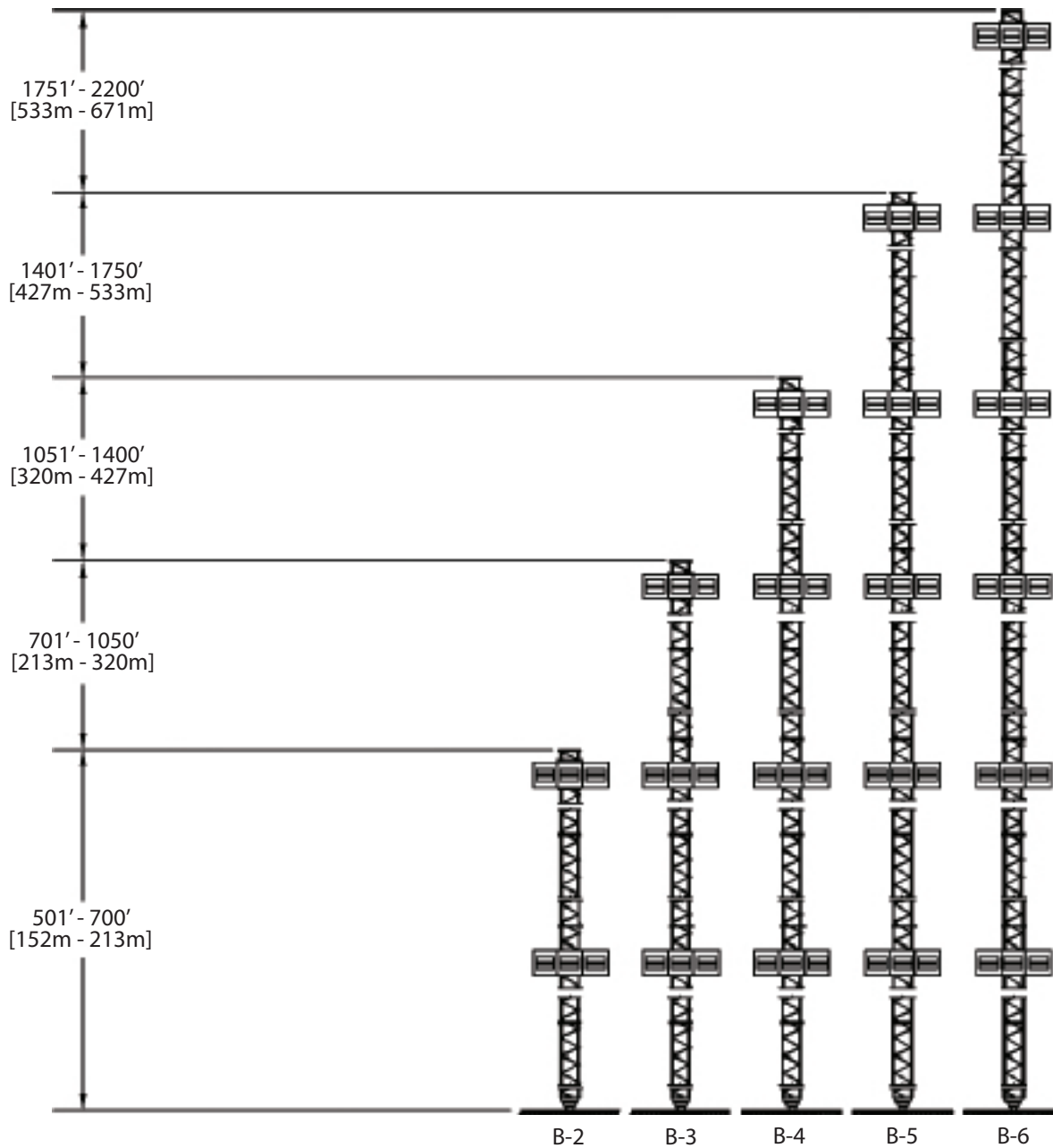

 L-856 (High Intensity Strobe)
3 Flashheads required per
level for 360° coverage

Day Protection = 200,000cd White Strobe
Twilight Protection = 20,000cd White Strobe
Night Protection = 2,000cd White Strobe



FAA STYLE "C" SERIES HIGH INTENSITY

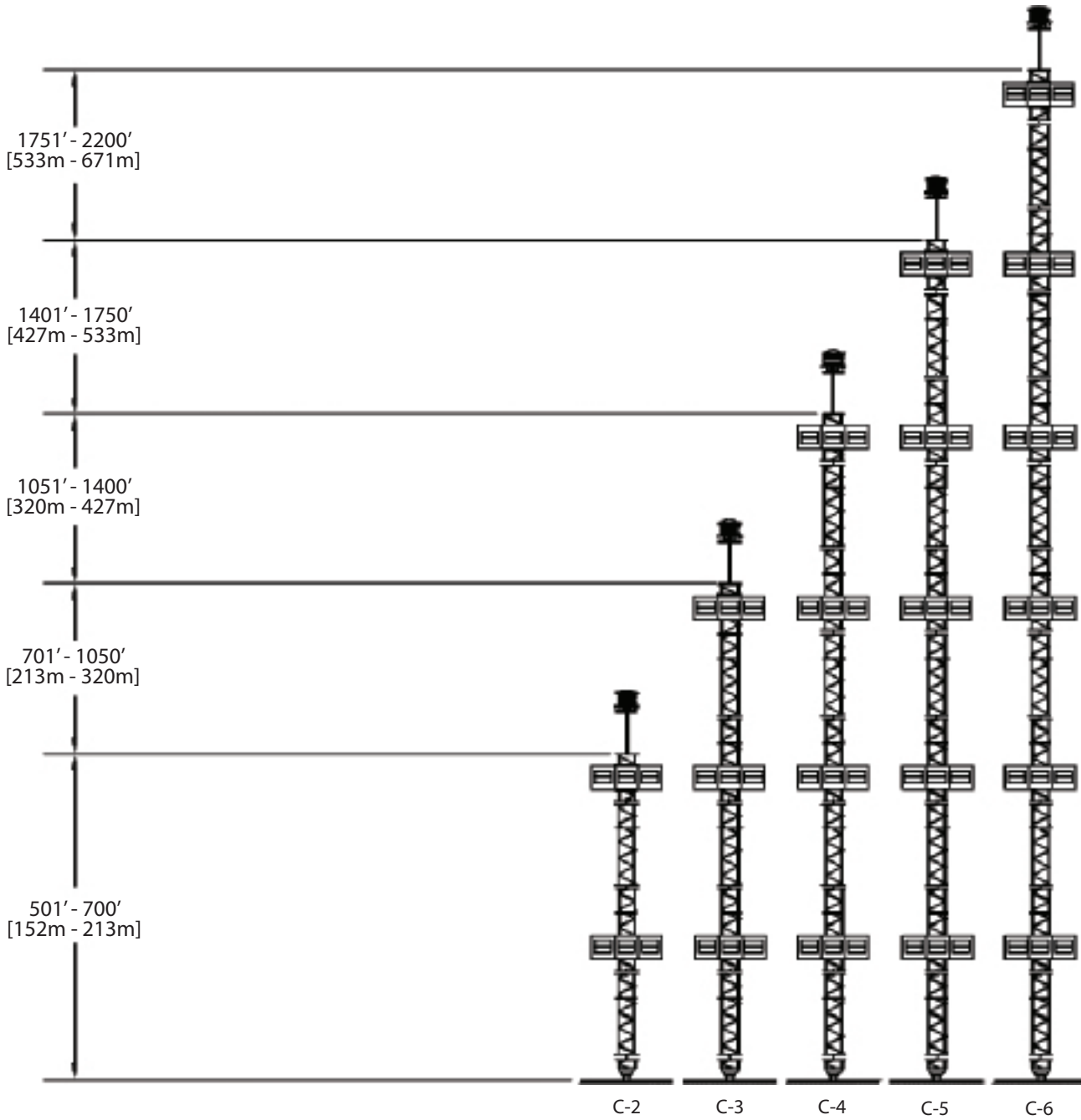

L-865 (Medium Intensity Strobe)
Required for appurtenances of 40'
or greater



L-856 (High Intensity Strobe)
3 Flashheads required per level
for 360° coverage

Day Protection = 200,000cd White Strobe
Twilight Protection = 20,000cd White Strobe
Night Protection = 2,000cd White Strobe

FAA STYLE "D" SERIES
MEDIUM INTENSITY WHITE

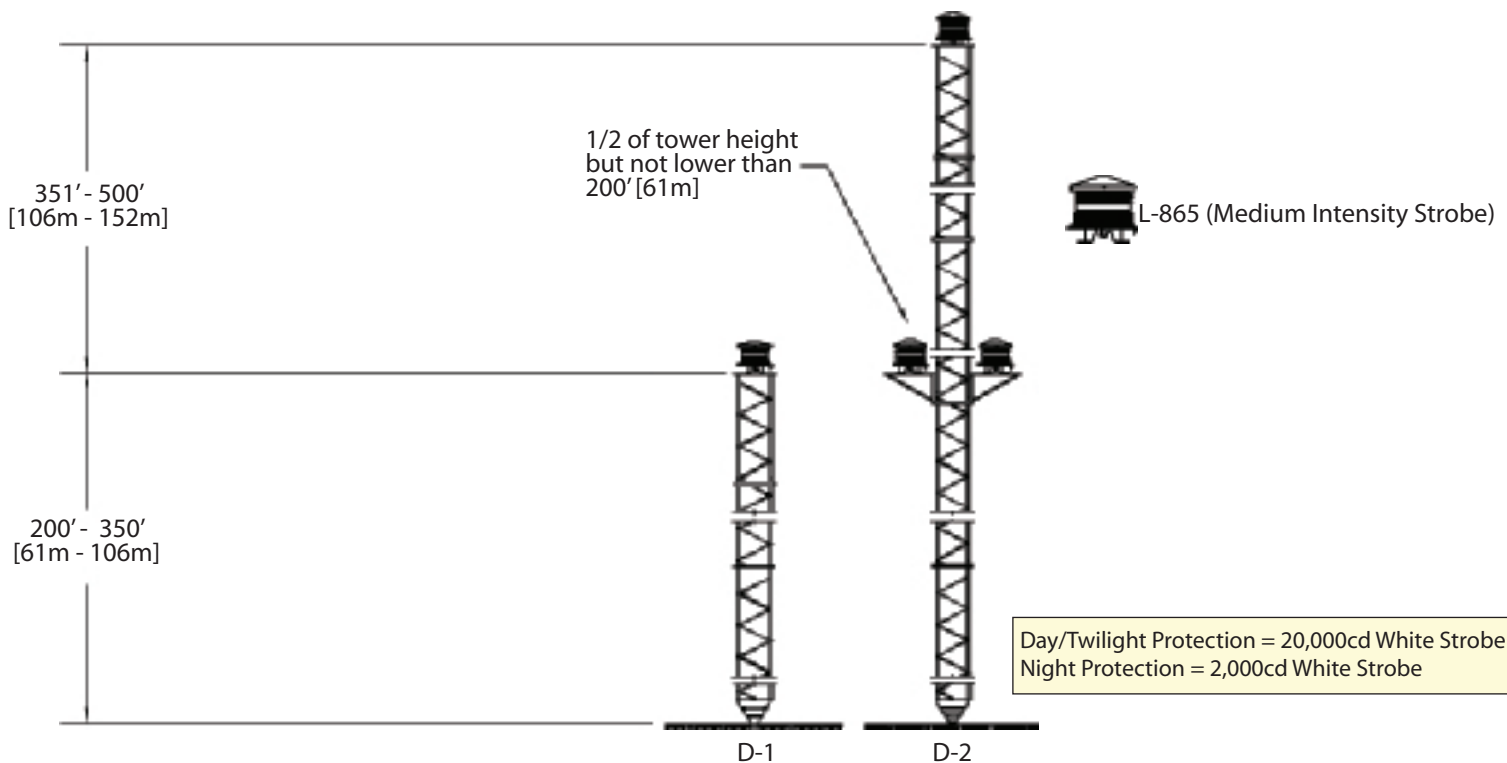

FAA STYLE "E" SERIES
MEDIUM INTENSITY DUAL

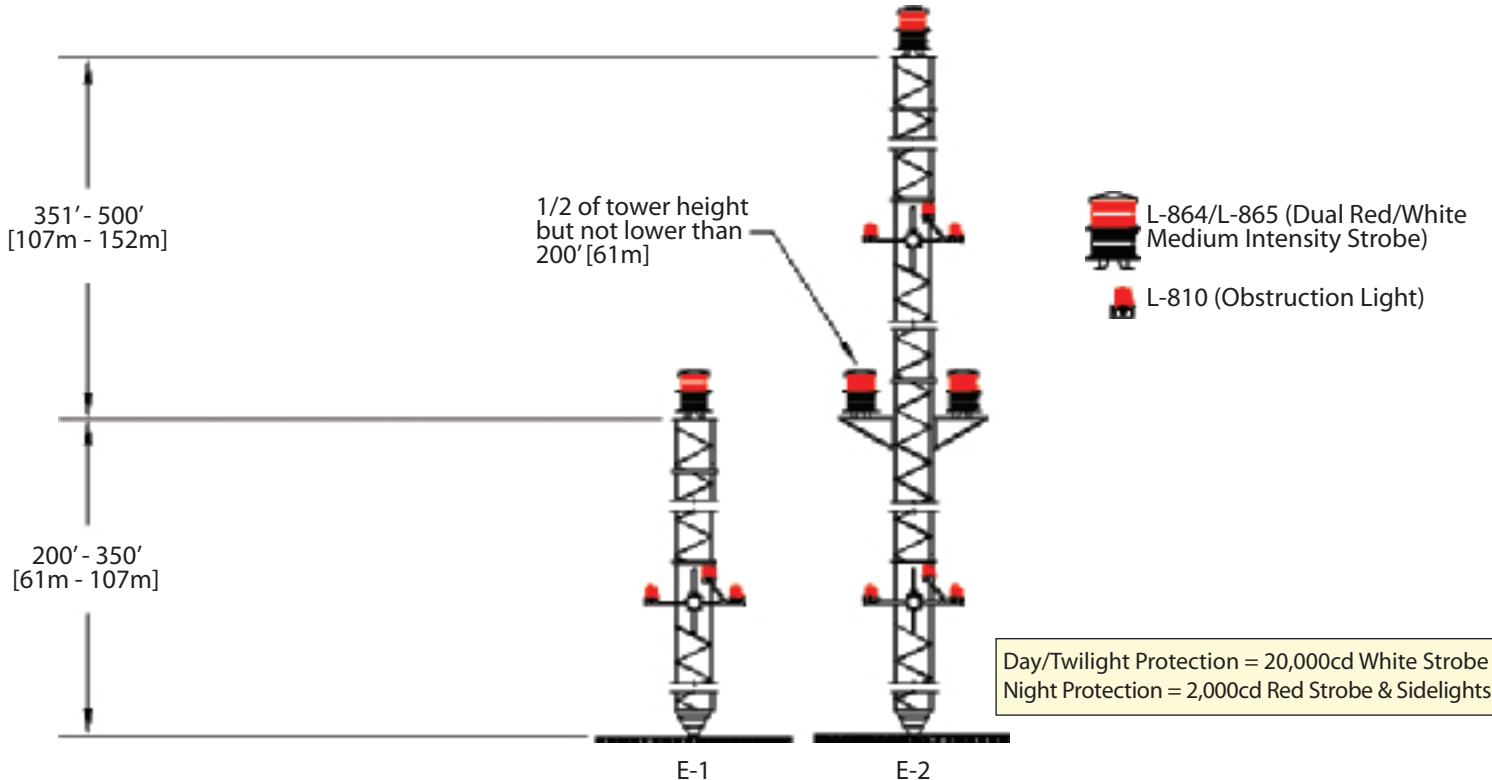



FAA STYLE "F" SERIES DUAL HIGH INTENSITY

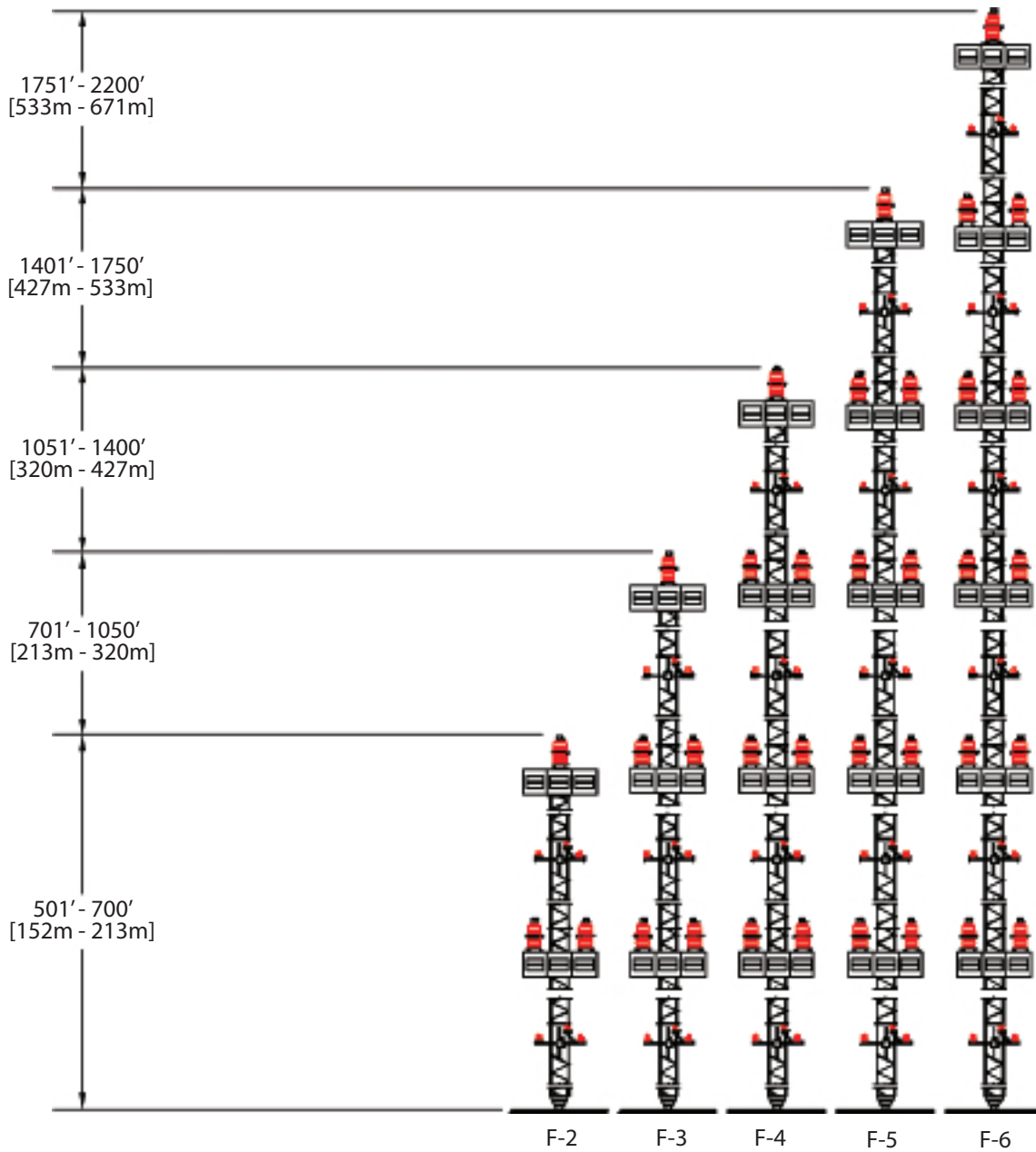

L-864 (Red Beacon)



L-810 (Obstruction Light)



L-856 (High Intensity Strobe)
3 Flashheads required per level
for 360° coverage

Day Protection = 200,000cd White Strobe Twilight Protection = 20,000cd White Strobe Night Protection = 2,000cd Red Beacon and Sidelights

ROHN CONSTRUCTION SERVICES





ROHN CONSTRUCTION SERVICES

ROHN's Construction Group has direct and immediate access to company management, engineering, production and shipment to provide you with the highest quality products and a wide range of services to help you complete your project. This direct and simple line of communication saves time and eliminates long distance contact between the manufacturer and installer. It enables us to answer questions internally before they have the chance to grow into costly delays.

We employ professionals with the expertise required to provide you a full turnkey communication project. We understand your needs, and when your job becomes a ROHN Construction project, we assign a single staff member to take charge. This one point of contact provides you the answers from scope changes to shipping schedules. At any time, you can be assured of the updated status of all phases of your project without having to contact multiple manufacturers and contractors.

ROHN's Construction Group, in addition to our in-house staff, has a network of suppliers, consultants and contractors to provide:

- Certified Tower Design Drawings
- Zoning and Permitting Assistance
- Environmental Studies
- Geotechnical Services
- Site Preparation
- Civil Construction
- Tower Foundations
- Equipment Shelter Foundations
- Tower Erection
- Equipment Shelter Installation
- Provide and Install Antennas and Transmission Lines
- System Testing
- Security Fencing
- Maintenance and Inspection

With over 60 years experience, what company could be more qualified to provide single source turnkey installation services more quickly and efficiently than ROHN? Nobody knows the products and installation methods the way ROHN does. Rest assured, ROHN is there to fulfill all your requirements.

CONSIDERATIONS, RECOMMENDATIONS & SAFETY INFORMATION





CONSIDERATIONS IN ERECTING TOWERS & SIMILAR PRODUCTS

Your local municipality or development may have established height and building standards governing the use of towers and similar products. Height restrictions are found in zoning ordinances and private deed restrictions. Building standards may be found in local building codes. Complying with these requirements is usually easy and will help to provide many years of safe and trouble free operation of your installation.

Zoning ordinances, building codes and private deed restrictions are complex legal documents. If you question whether they apply to you, consult a local attorney. Five minutes spent in advance may save hours later.

Zoning ordinances, building codes and deed restrictions are local. If you move from city to city, these restrictions may change.

Zoning ordinances are concerned with the type of buildings or other structures you can erect in your neighborhood. In terms of towers and similar products, zoning laws will tell you if your property is zoned for such items, and if so, what height limitations, if any are involved.

Building codes are concerned with the safety of buildings or other structures permitted by local zoning ordinances. Building codes will tell you where on your property you can put the installation and the type of loading you will need to consider.

Both zoning and building codes are usually administered by the same governmental agency, often known as the Department of Building and Safety or the Zoning Board.

The following steps will help make sure you have a safe, legal installation.

1. Check with the local governmental agency. Ask whether your home is zoned for the type of product you wish to install.
2. Look at the actual zoning ordinances. Pay special attention to the definitions. Many zoning ordinances distinguish between "buildings" and "structures". Others distinguish between towers physically attached to the house, either by guy wires or mounting and towers that are not attached.
3. See if a building permit is required. If so, be sure to get one. They are usually quite inexpensive, often less than one percent of the cost of the tower. As part of the building permit, a local inspector will check and make sure that the base, guy wires, etc. meet local safety requirements. Properly manufactured commercially made towers are extremely safe and have a large safety margin, but only if you install them according to the directions! If a permit is required and not obtained, your home-owner's insurance may not insure the tower and you have given neighbors, who might object, a reason to require you to take the tower down.
4. In a limited number of cases, you may need either a zoning variance or a conditional use permit to erect a structure higher than the local zoning board requirements. If so, it is far easier to apply in advance than to put up the structure and apply later. Most local governments are quite cooperative if you apply in advance and follow their rules. Variance provisions are used to provide flexibility from dimensional regulations such as setback or height restrictions. Conditional use permits are used where towers or antennas are not otherwise allowed. A public hearing is usually required before such permits are issued.
5. In addition to local ordinances, real estate developers or homeowners' associations may impose their own requirements in a subdivision. These requirements are usually known as deed restrictions or Conditions, Covenants and Restrictions (CC&R).

If you are thinking of moving into a new area, ask for a copy of the deed restrictions in advance of signing an offer to purchase the property. If you already own a home, a local realtor, title insurance company or lawyer can obtain copies of the deed restrictions, if any, for you. Don't take the word of the realtor who may be wrong.

If there are no deed restrictions, you need only be concerned with local zoning and building codes. If there are deed restrictions, read them carefully. Look at the definitions. See if there are any restrictions on outside structures or if a local architectural control committee must pass on any additions or changes to your property.

Deed restrictions are legal documents. A local lawyer familiar with real estate law can read the restrictions in only a few minutes and advise you. Even if the deed restrictions prohibit or restrict the size of towers and similar products, they may be unenforceable if many of your neighbors have erected such products and no objections have been raised.

RECOMMENDATIONS FOR SPECIFYING COMMUNICATION STRUCTURES

The basic standard for the design of steel antenna supporting structures is ANSI/TIA-222-G. Prior to issuing a specification, the specifying authority must have a working familiarity with this standard and its requirements. The following information is presented as the basis for preparing a tower specification.

Location: The tower is to be installed at _____ (include site name, state and county).

Tower Requirements: The structure is to be guyed/self-support/pole (circle one) with a normal overall structural height of _____ feet. The tower is to be designed for a _____ mph wind speed as defined by ANSI/TIA-222-G.

Ice loading shall be considered at _____ inches per ANSI/TIA-222-G and _____ mph wind speed.

The tower shall be designed to accommodate the following antenna loads: (At this point, please list all antennas, their mounting elevations, and transmission line requirements, providing as specific detail as possible. This should include microwave antenna azimuths, if known, and frequencies.)

Owner shall define structure class, exposure and topographic category (see pages 14-16).

The structure should be oriented on the property with one leg at _____ degrees, true north. Provide orientation if there is a specific orientation required due to property restrictions or desired by the purchaser. (Does not apply to poles).

The following appurtenances shall be incorporated into design as required by ANSI/TIA-222-G. (Note which appurtenances are to be provided with the structure.)

1. Climbing Ladder
2. Safety Device
3. Rest/Working Platforms
4. Transmission Line Support Ladders/Brackets
5. Obstruction Warning Lights and/or Paint
6. Antenna Mounts
7. Ice Shields
8. Grounding Materials
9. Waveguide Bridge
10. Port Size / Location for Poles

ROHN recommends the following requirements be included in specifications for the benefit of the purchaser:

The vendor shall be a manufacturer, primarily and continuously involved in the design and production of communication towers for at least ten years.

In order to specifically define responsibilities, the vendor shall maintain in-house control over the design and fabricating functions. Subcontracting of these responsibilities will be cause for rejection of a vendor's proposal.

Each structural member shall be identified by a part number and all parts with the same part number must be interchangeable. This will result in tower sections capable of being installed in any 120 degree rotation. Match marking requirements of tower sections by the manufacturer, for proper assembly, shall not be acceptable.

Tower leg members shall utilize a 50 KSI minimum yield strength. Tubular leg members with flange splices shall maintain an open interior diameter through the flange plate at least as large as the inside diameter of the tube and shall be welded externally and internally. Flange leg connections shall utilize a minimum of four bolts per leg.

All fabricated tower members shall be hot-dip galvanized after fabrication per ASTM Standard A123. Hardware shall be galvanized per ASTM Standard A153 and B695. Other types of coatings are not acceptable.

Four sets of tower assembly drawings illustrating all component part numbers and their respective locations shall be provided. As a minimum, assembly drawing shall be accompanied by a letter sealed by a registered professional engineer licensed in the state in which construction is to be performed, certifying that the tower meets all design requirements per ANSI/TIA-222-G.

The tower manufacturer shall be an AISC Certified Fabricator and shall maintain the highest quality steel manufacturing standards for production. Only AWS Certified Welders shall be employed for tower fabrication. A fully qualified quality control department shall be employed with a quality control manual maintained to establish minimum acceptable fabrication standards, procedures and requirements for documentation.

With the use of ANSI/TIA-222-G and the procurement and user guidelines (Annex A), accompanied by the commentary noted above, a thorough specification can be developed.

Copyright 2011 by ROHN Products, LLC. All rights reserved.

Phone (309) 566-3000 • Fax (309) 566-3079 • www.rohnnet.com • The Industry Standard
© 2011 ROHN PRODUCTS LLC

ROHN
Products LLC

313



GUIDELINES FOR THE PREPARATION OF A GEOTECHNICAL REPORT

I. PURPOSE AND INTENT

- a) The intended purpose of these guidelines is to assist the customer and/or owner to retain the services of a Geotechnical Engineer.
- b) It is not ROHN's purpose or intent to supercede the Geotechnical Engineer's knowledge, judgement and/or experience. It is the Geotechnical Engineer's responsibility to add or delete from these items, based on local site conditions and other factors.
- c) Additional information is provided in ANSI/TIA-222-G Annex G "Geotechnical Investigations"

II. DISCLAIMER

- a) ROHN will not accept any liability, either expressed or implied, for the use of, and omissions in, these guidelines.

III. EXPLORATORY BORINGS

- a) Borings should be taken at tower legs for self-supporting towers and at the base and anchor points for guyed towers. For small self-supporting towers, two borings may suffice. For large self-supporting towers, one boring should be taken at each tower leg. A "small" self-supporting tower is assumed to have a face width less than 20 feet and a compression load less than 50 kips per leg. For pole structures, one boring may suffice.
- b) The minimum boring depth should be 30 feet for pole structures, self-supporting towers and guyed tower bases. For guyed tower anchors, the minimum depth should be 15 feet. The actual depth of boring must be determined by the Geotechnical Engineer based on reactions, soil conditions and the type of foundation recommended.
- c) If borings cannot be advanced to the desired depth, rock corings should be taken. Rock Quality Designation (RQD) values and compressive strengths should be determined.

IV. GEOTECHNICAL REPORT

- a) The following properties, for each soil layer encountered, should be determined by field or laboratory testing and summarized in the geotechnical report:
 1. Soil classification and elevations
 2. Standard penetration values
 3. Unconfined compression strength
 4. Angle of internal friction
 5. Cohesion
 6. "In-Situ" soil density and moisture content
 7. Rock quality designation (RQD) and percent rock sample recovered
 8. Other properties unique to site conditions
- b) The following items should be discussed in the geotechnical report:
 1. Geological description of site
 2. Observed and expected ground water conditions
 3. Expected frost penetration depth
 4. Corrosion potential of soil and corrosion protection recommendations
 5. Site access and potential construction difficulties
 6. Dewatering or site drainage requirements
 7. Backfill material recommendations
 8. Settlement considerations
 9. Additional information to aid foundation designer
 10. Recommended types of foundations
 11. Design parameters for uplift, download and lateral load
 12. Factor of safety considered when allowable vs. ultimate design parameters are provided
 13. Recommended construction techniques and inspections

SAFETY INFORMATION

This information may save you from death or injury. Do not attempt to install or dismantle any ROHN products until you have read and understood the information in this document.

Do not attempt to install or dismantle ROHN products near any type of power line. Should your installation come into contact with power lines, you can be killed! Be sure your installation is out of falling distance of any overhead wires – including the lead to any building. Read all instructions carefully before you begin, or better yet, call a professional – it may save your life.



ROHN's ACWS sign must be attached to all poles, towers, guyed mast bases in a location which is conspicuous and readable from the ground so that all personnel are notified and warned. Aluminum wire is furnished for attaching signs. ROHN recommends you check frequently to make sure the sign has not been removed. These 6" x 9" signs may be ordered, specify part number ACWS.

Tower Erectors – Please see that these signs are attached per the instructions above before leaving the site.

Guyed and bracketed towers are not self-supporting at any height. When installing or dismantling a guyed tower always consult your local tower installer. The condition of a used tower is difficult to determine and in the process of dismantling you could be killed or injured. Dismantling and installation may require the use of temporary steel guys.

General Information & Precautions

ROHN field technicians, warning labels, catalogs, guy charts, etc. are available from ROHN. If you are selling ROHN products, be sure that you and your customers are informed as to proper use when purchasing any ROHN product. All towers, masts and poles should be installed or dismantled by experienced and trained personnel.

Mixing of Products

The mixing of so-called interchangeable copies of ROHN products with ROHN products is dangerous and voids all engineering or warranty data supplied by ROHN. Materials used by the so-called copies are not the same quality and have not been tested or engineered by ROHN.

Who should install or Dismantle ROHN Products?

Installing, dismantling and rigging ROHN products requires specialized skills and experience. Information supplied by ROHN assumes that all products will be installed or dismantled by personnel having these skills and having worked with similar products before. No one should attempt to install or dismantle ROHN products without these skills and experience. ROHN assumes no liability if faulty or dangerous practices are used. There are available trained and experienced personnel to assist in installation, maintenance, and disassembly. Contact your local installer if consultation or assistance is required.

What about used material?

ROHN does not recommend or warrant in any way the use of used materials. The use of used materials voids all warranties set forth by ROHN because no one knows if the used material has been misused, overloaded, or damaged. If, for some reason, materials are re-used, all new, galvanized, high strength bolt assemblies must be used.

General Precautions

Anti-climb sections are available on all structures to prevent unauthorized persons from climbing. Installation and dismantling may require the use of temporary steel guys. All installations must be grounded per local and national codes. All types of installations must be thoroughly inspected by qualified personnel and re-marked with hazard and warning labels at least twice a year to ensure safety and proper performance. ROHN makes available many items, which may or may not be required for your particular installation. Some items available in various types and sizes are: safety climbing devices, ladders, safety cages, anti-climb devices, work platforms, F.A.A. painting and lighting, grounding, and fencing. Special product services and special packaging are also available. Based on local, state, or federal laws and building codes for your area, it may be necessary for your particular installation to have special items or be given special consideration. If there are any special requirements for your particular installation, be sure to include them in your request for quotation and on your order form. ROHN cannot be responsible for any omission at any time.



SAFETY INFORMATION

About OSHA

In accordance with the Occupational Safety and Health Act regulations, parts are available incorporating features, which will permit a safe product. It is a policy of ROHN Products to design and make our products safe to use without hazards to people and/or property. We ask that you list specific requirements you wish us to comply with in accordance with the intended use of a product. These requirements may or may not affect the price of the materials and equipment under consideration for purchase. We would be happy to answer any additional questions you may have.

About Step Bolts

Structures may or may not include step bolts. Step bolts are supplied as a convenience during construction. Step bolts are intended to be climbed by professional Competent Climbers only. 100% Fall protection is required at all times. Climber safety devices are required on all structures 10 ft. or greater in height. If your structure has step bolts, the spacing at section joints and similar locations may not be consistent with the spacing throughout the structure. Flange plates, guys, attachments to legs, appurtenances, etc. may be an obstruction to continuous climbing. Climbing step bolts is dangerous and can cause serious injury or death. Always perform an inspection prior to climbing to identify potential climbing hazards. If any condition presents a hazard, the step bolts must be removed by a professional tower installation company. ROHN will not be responsible for the use of step bolts. If you wish to use step bolts, the responsibility for their use will be totally yours or your customers.

Installation & Dismantling Safety Instructions

Each year people are killed, mutilated, or receive severe permanent injuries when attempting to install or dismantle towers, poles, and other structures. In many of these cases, the victim was aware of the dangers of electrocution but did not take adequate steps to avoid the hazard. Good practice is to install your products away from power lines and obstructions. Your dealer carries a complete line of installation and grounding hardware. For your safety and to help you achieve a safe installation, please read and follow the safety precautions below. They may save your life! Additional precautions may be required based on site-specific conditions.

1. If you are not experienced in installing or dismantling, please, for your own safety as well as others, seek professional assistance. Consult your dealer.
2. Select your installation site with safety, as well as performance, in mind. REMEMBER: Power lines and phone lines look alike. For your safety, assume that any overhead lines can kill you.
3. Call your power company. Tell them your plans and ask them to look at your site. This is little inconvenience, considering your life is at stake.
4. Before you begin, plan your installation or dismantling procedure carefully. Successful installation or dismantling is largely a matter of coordination. Each person should be assigned to a specific task and should know what to do and when to do it. One person should be designated as the "boss" to call out instructions and watch for signs of trouble.
5. When installing or dismantling, REMEMBER: Do not use a metal ladder. Do not work on a wet or windy day or if a thunderstorm is approaching. Do dress properly – shoes with rubber soles and heels, rubber gloves, long sleeve shirt or jacket, and a hard hat and safety glasses.
6. If the assembly starts to drop, get away from it and let it fall. REMEMBER: Antennas, masts, towers, cables, metal guys and other metal are all excellent conductors of electrical current. Even the slightest touch of any of these parts to a power line completes an electrical path through the installer!
7. If any part of the assembly should contact a power line – Don't touch it or try to remove it yourself. Call your local power company. They will remove it safely.
8. If an electrical accident should occur – don't grab hold of the person in contact with the power line or you too may be electrocuted. Use a dry board, stick or rope to push or pull the victim away. Have someone call for medical help.

1. All quotation, proposals, prices, or other terms are made for acceptance within 30 days (after 30 days, prices in effect at time of shipment will apply) and shipment within 30 days of purchase order date, unless otherwise stated. They are subject to change without notice; however, ROHN invites your request for an extension. They are also subject to Credit and Marketing Department approval prior to acceptance. No other price protection is available.

2. Every effort will be made to maintain shipping schedules, either on ROHN equipment or via common carrier. ROHN cannot be responsible for delays in shipping caused by state or local agencies with regard to permits, routing, weather, detours, etc. All deliveries and schedules are contingent on availability of raw materials, fuel, and transportation. ROHN will not be liable for damages on account of any delays or abnormalities caused in shipping due to causes beyond our reasonable control. ROHN reserves the right to make partial shipments and to submit invoices accordingly.

3. Changes or modifications to orders can be made only by written agreement executed by all parties affected thereby, which agreement shall include any price modification.

4. ROHN's responsibility ceases upon delivery of all shipments to the carrier. The unloading of all shipments is the responsibility of the Buyer, not the carrier or ROHN. Buyer is warned against receipting for merchandises until careful inspection has been made. Any claim made against ROHN must be made within 90 days after receipt of merchandise. All merchandise leaving ROHN's factory has been carefully inspected and ROHN does not assume responsibility for damages or shortages which occur in transit. Buyer must make all claims and report all damages and losses to the delivering transportation company.

5. No federal, state, or local taxes are included in quoted prices. All quotations, proposals, prices, or other terms are subject to increase without notification by the amount of any sales, excise, or other tax levied or charged to seller by any governmental agency and any such tax will be passed onto purchaser as a tax or as an addition to the selling price. This also applies to all costs incurred due to local statutes or governmental regulations.

6. Orders are not subject to cancellation by Buyer except by written agreement with seller. Any order canceled, after any work has been done by ROHN, such as drawings, production, etc., will have a cancellation charge, to be determined solely at the discretion of ROHN for whatever work has been performed with a minimum of 25% of the purchase order price. If Buyer so chooses, he shall have the right to receive the material already performed at time of cancellation at the quoted price. If an order is canceled before any work has been done by ROHN, a \$200 cancellation charge will apply.

7. Material received may not be returned by Buyer except by written agreement with seller. In all cases, permission must be secured from ROHN prior to the returning of any goods for credit. All returned goods are subject to a minimum service charge of 25%, plus all transportation charges, and are subject to inspection by ROHN. Returned goods will be offered and paid for only upon proof of purchase (i.e. invoice no.) and credit will be issued against invoice value. ROHN reserves the sole right to determine amount of credit to be issued on all goods returned for credit. Only standard, currently manufactured ROHN products may be considered for return and credit. Unsaleable products will be scrapped and no credit will be received. If returned goods are determined to have no value and Buyer wishes them returned, the Buyer will be charged return freight. Safety equipment, erection equipment, insulators, transformers, nuts and bolts are not returnable.

8. ROHN warrants the commercial items of its manufacture only, to be reasonably fit for the purpose for which they are manufactured and sold, provided, however, that this warranty shall be effective only if purchaser installs all material according to ROHN's recommendations and specifications and that purchaser during the warranty period shall regularly, not less than semi-annually, inspect and properly maintain all items. Any item found unfit for its purpose within 12 months from date of delivery will be repaired or replaced free of charge, F.O.B. ROHN's plant. ROHN shall be immediately notified in writing of such unfitness. ROHN reserves the sole right to determine if any material is to be repaired or replaced free of charge or to be supplied at ROHN's standard prices. Such obligation shall be limited to parts returned for inspection, properly packed and expenses prepaid, and providing inspection shall satisfactorily indicate defects. The warranty herein made is in lieu of all other warranties and, except as expressly stated herein, ROHN does not make and there are no warranties or obligations of any kind or nature whatsoever either expressed or implied including, but not restricted to, warranty or obligations as to product, material, workmanship, or manufacture or as to the use of the items covered hereby. ROHN shall not under any circumstances be liable to third persons for any claims for damages including direct, special, indirect, or consequential damages for any reason. The Buyer agrees to indemnify and to hold ROHN harmless for, of, and from any loss, claims, damages, expenses and attorney's fees, including but not limited to, any fines, penalties and corrective measures ROHN may sustain by reason of Buyer's failure to comply with said laws, rules, and regulations in connection with the performance of this sale. The above warranty warranted applies only to items manufactured by ROHN. Items not manufactured by ROHN are guaranteed only to the extent and in the manner warranted and guaranteed to ROHN by the manufacturer of

such items and then only to the extent ROHN is liable to enforce such warranty or guarantee. ROHN will assume no responsibility for the adequacy of any product if material is used which is not totally supplied by ROHN. The above sets forth the only warranty made by ROHN in connection with items manufactured or sold by it, and any provisions in any proposals, specifications, advertising, or other provisions hereof, are merely descriptive and are not to be construed as warranties made by ROHN. All warranties are void on drawings made by others, whether by a professional engineer, sealed or not, that are not rechecked by ROHN and approved by ROHN. ROHN assumes no liability for the adequacy of the drawings or the product. Without limiting the generality of the foregoing, the Buyer hereby indemnifies ROHN and hold ROHN harmless from any and all claims and/or damages (including direct, special, indirect or consequential damages, attorneys' fees and costs) relating to or arising out of any highway structure or component not designed by ROHN. ROHN hereby disclaims any and all warranties, including express or implied warranties of merchantability and fitness for any particular purpose, relating to or arising out of metal fatigue.

9. ROHN reserves the right to change or modify the product and construction of any product manufactured by ROHN and to substitute material equal to or superior to that originally specified.

10. Buyer agrees not to disclose or make available to any third party processes, drawings, specifications, reports, photographs, data and other technical or proprietary information relating to ROHN products without obtaining prior written consent of ROHN.

11. No proposal, order, quotation, or acceptance may be changed or varied by verbal agreement, and all orders are accepted only under the provisions set forth herein.

12. Purchase orders and requests for quotations must be submitted in writing to ROHN. It is the responsibility of the Buyer or Buyer Representative to provide ROHN design criteria (environmental loads, equipment loads, operational limitations, geotechnical information, etc.) based on site-specific data. In designing the product for the Buyer, ROHN is relying solely and entirely on design criteria provided by the Buyer to ROHN. Without limiting the generality of the indemnities in these Terms & Conditions, the Buyer hereby indemnifies ROHN and holds ROHN harmless from and against any and all claims and/or damages (including direct, special, indirect or consequential damages, attorneys' fees and costs) relating to or arising out of any inaccuracy or incompleteness in design criteria provided to ROHN by the Buyer, and the Buyer waives all claims against ROHN for same.

13. If outside source inspection, assembly, etc. is required prior to shipment of an order, \$50.00 per man hour (plus equipment time, if applicable) is chargeable, with \$300.00 as a minimum.

14. Any welding inspection required by Buyer or Buyer's specifications must be done at ROHN's plant prior to packing and shipment of material from ROHN's plant.

15. A minimum charge of \$25.00 will be billed for special handling and preparation of material for air shipments.

16. ROHN reserves the right to apply all remittances and credit memos to the oldest outstanding balance in your account. No credits will be issued for any reason against a purchase order whose billing is more than 90 days old. Buyer corrections or complaints must be made within this period of time.

17. Standard catalog prices do not include special drawings or product evaluations. If any are required, there will be a charge.

18. ROHN at all times reserves the right to take pictures of any or all of its products after installation for advertising purposes, except those which are under classified governmental control.

19. The Buyer will be responsible for any extra charges incurred on prepaid shipments.

20. A service charge not to exceed 2% per month or maximum allowable per State law will be billed on all accounts not paid within 30 days of invoice date.

21. Minimum total net worth of merchandise which can be ordered is \$100.00. Any orders placed for less will be billed at \$100.00.

22. Storage charges will be .02% of invoice amount per day with a minimum charge of \$8.00 a day. These charges will be invoiced on a monthly basis for material requested to be withheld from shipment starting 30 days from the initial notification from ROHN, that the material was available for shipment.

23. All CIA requirements must be met with certified checks or money orders to insure prompt shipment.

24. All expenses incurred by ROHN during any collection effort shall be charged to the Buyer.

25. There will be a minimum of a \$100 fee per truck or container, for ROHN to receive, handle and pack for reshipment, any material not purchased through ROHN, but drop shipped to ROHN for shipment with a ROHN structure. This includes light kits, platforms, mounts, rigging equipment, etc. that is provided by others. There will be a minimum \$250 per truck or container for those drop shipped items that must be handled with ROHN forklifts or other mechanical device.



The information contained in this catalog does not purport to cover all details or variations in equipment nor provide for every possible contingency to be met in connection with installation, operation or maintenance. ROHN assumes no obligation to revise any of the information contained in this catalog if changes are made in criteria or evaluation techniques at a later date. Should particular situations arise which are not covered sufficiently herein for the purchasers' purposes, the matter should be deferred to ROHN.

All towers, poles and masts must be installed and dismantled by experienced and trained personnel.

All installations must be thoroughly inspected by qualified personnel and remarked as required with hazard and warning labels at least twice a year to ensure safety and proper performance.

All installations must be grounded per local and national codes.

The mixing of so-called interchangeable copies of ROHN products is dangerous and voids all data or warranty supplied by ROHN. Materials used by others are not the same quality and have not been tested or checked by ROHN to conform to the same quality standards. Mixing of non-ROHN items may endanger lives and cause serious failures and financial misfortune for all concerned.

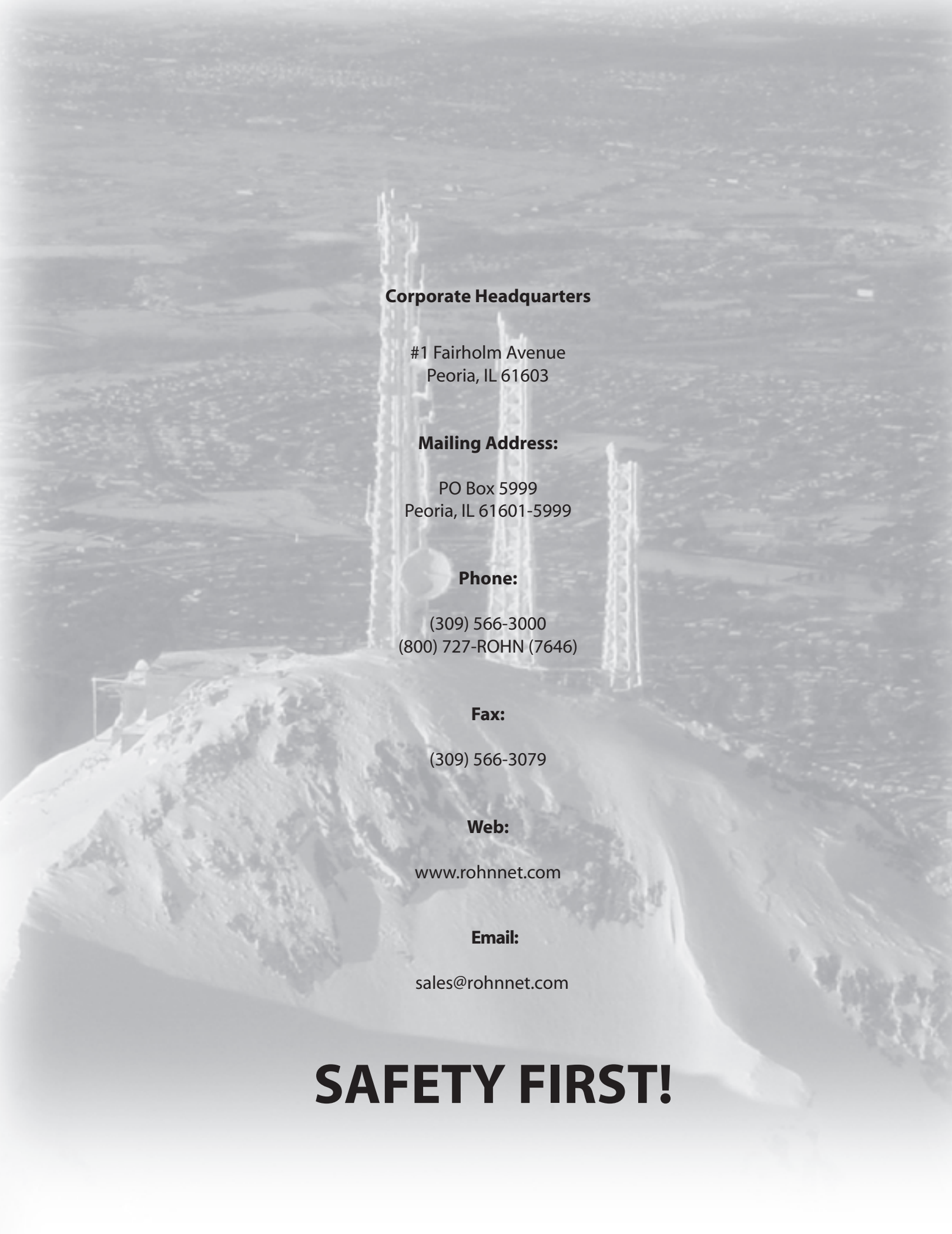

Corporate Headquarters

#1 Fairholm Avenue
Peoria, IL 61603

Mailing Address:

PO Box 5999
Peoria, IL 61601-5999

Phone:

(309) 566-3000
(800) 727-ROHN (7646)

Fax:

(309) 566-3079

Web:

www.rohnnet.com

Email:

sales@rohnnet.com

SAFETY FIRST!



Corporate Headquarters

**#1 Fairholm Avenue
Peoria, IL 61603, USA**

www.rohnnet.com

Mail To:

**PO Box 5999
Peoria, IL 61601-5999**

**Phone: (800) 727-ROHN(7646)
(309) 566-3000**